

Vectra
GENISYS[®]

Intelect
LEGEND[®]XT

Intelect[®]
VET



Moving
Rehabilitation
Forward™

Therapy Systems:

Genisys Therapy System

(Serial Numbers- 1000 and above)

Intelect Legend XT Therapy System

(Serial Numbers- 1000 and above)

Intelect Vet Therapy System

(Serial Numbers- 1000 and above)

Optional Accessories:

Channel 3/4 Electrotherapy Module

(Serial Numbers- 1000 and above)

NiMH Battery Module

(Serial Numbers- 1000 and above)

sEMG Module (Genisys Only)

(Serial Numbers- 1000 and above)

Laser Module (Genisys Only)

(Serial Numbers- 1000 and above)

Therapy System Cart

Operator Remote Control

Therapy Systems

SERVICE MANUAL

TABLE of CONTENTS

FOREWORD	1	4.1 VECTRA GENISYS, INTELECT LEGEND XT, AND INTELECT VET THERAPY SYSTEMS	18
1- THEORY OF OPERATION	2	A. Therapy Systems Physical Specifications	18
1.1 OVERVIEW	2	4.2 ELECTROTHERAPY WAVEFORM SPECIFICATIONS	19
1.2 POWER SUPPLY CIRCUITS	2	A. IFC (Interferential) Traditional (4 Pole)- Figure 4.2	19
1.3 CONTROL BOARD	2	B. TENS- Asymmetrical Biphasic- Figure 4.3	19
1.4 STIM BOARD	2	C. TENS- Symmetrical Biphasic- Figure 4.4	20
1.5 ULTRASOUND BOARD AND APPLICATOR (COMBINATION SYSTEMS ONLY)	2	D. High Voltage Pulsed Current (HVPC)- Figure 4.5	20
1.6 USER INTERFACE AND ACCESSORIES	2	E. VMS™ - Figure 4.6	21
2- SAFETY PRECAUTIONS	4	F. IFC (Interferential) Premodulated (2p)- Figure 4.7	21
2.1 PRECAUTIONARY DEFINITIONS	4	G. Russian- Figure 4.8	22
Caution	4	H. Microcurrent- Figure 4.9	22
Warning	4	I. VMS™ Burst- Figure 4.10	23
Danger	4	J. DC (Direct Current)- Figure 4.11	23
Dangerous Voltage	4	K. Iontophoresis	23
Laser	4	4.3 ULTRASOUND SPECIFICATIONS	24
Corrosive	4	4.4 DESCRIPTION OF DEVICE MARKINGS	25
Laser Eye Protection	4	4.5 LASER MODULE SPECIFICATIONS	26
Spontaneous Combustion	4	4.6 LASER APPLICATOR SPECIFICATIONS	27
Biohazardous Materials	4	A. Single Diode Applicators	27
Non-ionizing Electromagnetic Radiation	4	B. 9, 13, and 19 Diode Applicators	28
Note	4	C. 33 Diode Applicators	29
2.2 PRECAUTIONARY INSTRUCTIONS	5	5- TROUBLESHOOTING	30
3- NOMENCLATURE	7	5.1 THERAPY SYSTEM ERROR MESSAGES	30
3.1 VECTRA GENISYS, INTELECT LEGEND XT AND INTELECT VET THERAPY SYSTEMS	7	5.2 THERAPY SYSTEM TESTING	38
A. Vectra Genisys, Intellect Legend XT and Intellect Vet Therapy Systems	7	5.3 VISUAL INSPECTION	39
B. Vectra Genisys, Intellect Legend XT and Intellect Vets Combination Therapy Systems	8	5.4 LEAKAGE TESTS	39
C. Vectra Genisys, Intellect Legend XT and Intellect Vet Electrotherapy Systems	9	5.5 UNIT STARTUP AND FAN TESTING	39
D. Vectra Genisys, Intellect Legend XT and Intellect Vet Channel 3/4 Electrotherapy Module	10	5.6 STIMULATOR TEST SYSTEM SETUP	40
E. Vectra Genisys Intellect Legend XT and Intellect Vet NiMH Battery Module	11	5.7 VMS™ MODE TEST	41
F. Vectra Genisys and Intellect Vet Laser Module	12	5.8 INTERFERENTIAL MODE TEST	42
G. Vectra Genisys and Intellect Vet Laser Applicators	13	5.9 PREMODULATED MODE TEST	43
H. Vectra Genisys Dual Channel sEMG Module	14	5.10 RUSSIAN MODE TEST	44
I. Vectra Genisys, Intellect Legend XT and Intellect Vet Therapy Cart	15	5.11 MICROCURRENT MODE TEST	45
J. Vectra Genisys, Intellect Legend XT and Intellect Vet Operator Remote Control	16	5.12 HIGH VOLTAGE PULSED CURRENT (HVPC) MODE TEST	46
3.2 VECTRA GENISYS, INTELECT LEGEND XT AND INTELECT VET THERAPY SYSTEM HARDWARE AND SOFTWARE SYMBOL DEFINITIONS	17	5.13 MICROCURRENT PROBE MODE TEST	47
A. Hardware Symbols	17	5.14 ULTRASOUND TESTS	49
B. Software Symbols	17	5.15 ULTRASOUND APPLICATOR IDENTIFICATION TEST	49
C. Optional Accessory Symbols	17	5.16 ULTRASOUND APPLICATOR OUTPUT TEST	50
4- SPECIFICATIONS	18	5.17 ULTRASOUND DUTY CYCLE TEST	51
		5.18 COMBO OPERATION TEST	52
		5.19 sEMG AND sEMG + ELECTRICAL STIMULATION TESTS	53
		5.20 NiMH BATTERY MODULE CHECKS	57
		6- REMOVAL/REPLACEMENT	59
		6.1 CHANNEL 3/4 ELECTROTHERAPY, NiMH BATTERY, AND LASER MODULE INSTALLATION AND REMOVAL	59
		6.2 sEMG MODULE INSTALLATION AND REMOVAL (GENISYS ONLY)	63

TABLE of CONTENTS

6.3	THERAPY SYSTEM- SEPARATING TOP & BOTTOM	66
6.4	THERAPY SYSTEM- FAN	68
6.5	THERAPY SYSTEM- CONTROL BOARD ASSEMBLY	69
6.6	THERAPY SYSTEM- KEYMAT ASSEMBLY	70
6.7	THERAPY SYSTEM- CONNECTOR BOARD	71
6.8	THERAPY SYSTEM- ULTRASOUND BOARD (COMBINATION SYSTEMS ONLY).....	72
6.9	THERAPY SYSTEM- STIM BOARD (CHANNELS 1/2)	73
6.10	THERAPY SYSTEM- POWER SUPPLIES	74
6.11	CHANNEL 3/4 ELECTROTHERAPY MODULE CONNECTOR BOARD	76
6.12	CHANNEL 3/4 ELECTROTHERAPY MODULE STIM BOARD ...	77
6.13	MOUNTING AND DISMOUNTING THERAPY SYSTEM AND THERAPY SYSTEM CART	78
7-	GENERAL MAINTENANCE	79
7.1	CLEANING THE SYSTEM	79
7.2	CALIBRATION REQUIREMENTS	79
7.3	FIELD SERVICE	79
7.4	FACTORY SERVICE	79
8-	ULTRASOUND CALIBRATION	80
8.1	GENERAL.....	80
9-	PARTS.....	81
9.1	TOP TO BOTTOM ASSEMBLY.....	81
9.2	COMBINATION SYSTEM BASE ASSEMBLY	82
9.3	COMBINATION STIM & ULTRASOUND PC BOARD ASSEMBLY.	83
9.4	TOP HOUSING ASSEMBLY.....	84
9.5	VECTRA GENISYS AND INTELECT VET CONTROL BOARD ASSEMBLY.....	85
9.6	INTELECT LEGEND XT CONTROL BOARD ASSEMBLY	86
9.7	CHANNEL 3/4 ELECTROTHERAPY MODULE ASSEMBLY.....	87
10-	SCHEMATICS.....	88
10.1	VECTRA GENISYS, INTELECT LEGEND XT, AND INTELECT VET THERAPY SYSTEM- CONTROL BOARD..	88-90
10.2	VECTRA GENISYS, INTELECT LEGEND XT AND INTELECT VET THERAPY SYSTEM-ULTRASOUND PC BOARD	91-93
10.3	VECTRA GENISYS, INTELECT LEGEND XT AND INTELECT VET THERAPY SYSTEM- STIM BOARD	94-103
10.4	VECTRA GENISYS, INTELECT LEGEND XT AND INTELECT VET THERAPY SYSTEM- CONNECTOR BOARD	104
10.5	VECTRA GENISYS, INTELECT LEGEND XT AND INTELECT VET THERAPY SYSTEM- CHANNEL 3/4 ELECTROTHERAPY MODULE CONNECTOR BOARD	105
10.6	VECTRA GENISYS, INTELECT LEGEND XT AND INTELECT VET THERAPY SYSTEM- POWER SUPPLIES	106
10.7	VECTRA GENISYS AND INTELECT VET THERAPY SYSTEM- LASER MODULE BOARD	107
11-	WARRANTY.....	108-109

Read, understand, and follow the Safety Precautions and all other information contained in this manual.

This manual contains the necessary safety and field service information for those field service technicians, certified by Chattanooga Group, to perform field service on the Vectra Genisys, Intelect Legend XT and Intelect Vet Therapy Systems, modules, and accessories.

At the time of publication, the information contained herein was current and up-to-date. However, due to continual technological improvements and increased clinical knowledge in the field of electrotherapy, ultrasound, Iontophoresis, and Laser therapy, as well as Chattanooga Group's policy of continual improvement, Chattanooga Group reserves the right to make periodic changes and improvements to their equipment and documentation without any obligation on the part of Chattanooga Group.

It is the sole responsibility for certified field service technicians to stay informed and trained in the latest technology utilized in the Vectra Genisys, Intelect Legend XT and Intelect Vet Therapy Systems by Chattanooga Group. From time to time, as significant improvements are incorporated, service bulletins will be produced and made available on our web site (chattgroup.com) in lieu of reprinting a complete manual prematurely. These service bulletins will provide updated service information and technological improvements to the Vectra Genisys, Intelect Legend XT and Intelect Vet Therapy Systems for use by certified service technicians.

Due to the complex nature of the technology utilized by Chattanooga Group, the recommended troubleshooting techniques are to determine "Bad Board" and board replacement only. No board component level troubleshooting is recommended, nor will information or parts be supplied by Chattanooga Group.

Any board component level troubleshooting performed will be at the sole risk and liability of the certified field service technician performing such troubleshooting techniques. Performance of such techniques may render the warranty null and void.

The Vectra Genisys and Intelect Legend XT equipment is to be used only under the prescription and supervision of a licensed medical practitioner.

The Intelect Vet is to be used only under the prescription and supervision of a licensed veterinarian.

1.1 OVERVIEW

The Vectra Genisys, Intellect Legend XT and Intellect Vet Therapy Systems are comprised of several PC board assemblies housed within a common enclosure. These assemblies each support a distinct function in the product. The basic elements are User Interface, Control Board, Stim Board, Ultrasound Board, Ultrasound Applicator, and Power Supply Circuits.

When a Module (Channel 3/4 Electrotherapy, NiMH Battery, Laser, or sEMG) is installed, the Control Board software automatically recognizes that a Module has been installed and prompts the installer to perform certain tasks, for verification of Module installed, to make the respective Module fully functional. No additional software installation is required as the Therapy System contains all necessary software to accommodate any Module installation.

1.2 POWER SUPPLY CIRCUITS

A universal input 100 Watt power supply provides the Control Board and Stim Board of the system with 24 volts DC. The supply is connected to the mains at all times when the cord is attached. The 24 VDC supply is regulated locally at each PC board as required. On Combination Systems, a separate universal 75 Watt Power Supply provides 24 volts DC to the Ultrasound PC Board. The 24 volt DC power is regulated at the board, as required.

1.3 CONTROL BOARD

The Control Board serves just as its name implies. It controls the operation of the stim board, ultrasound board, user interface, optional modules, and accessories. The control board communicates to the stim boards and ultrasound board through a proprietary bus. The control board drives the display. The control board reads the menu buttons. The control board also reads the amplitude and the contrast control (Intellect XT Only) systems. The control board reads and manages the Multimedia (MMC) Card, Patient Data Card, and sEMG Data Card. Sound output is generated by the control board and routed to an internal speaker. The control board reads the optional Patient Interrupt Switch and Operator Remote Control (used to administer Manual Stimulation Therapy).

1.4 STIM BOARD

The Stim Board creates all muscle stimulation output. Communications to the Stim Board is via a proprietary bus. A Processor on the Stim Board acts on messages passed to it by the Control Board to set up waveforms and adjust output amplitude. Information can likewise be passed from the Stim Board back to the Control Board for monitoring Current, Microcurrent Probe (Vectra Genisys and Intellect Legend XT only) Contact Quality indication, etc. If the Stim Board does not respond as expected to a command from the Control Board, output is stopped and an Error Message is generated.

1.5 ULTRASOUND BOARD AND APPLICATOR (COMBINATION SYSTEMS ONLY)

The Ultrasound Board generates the 1 or 3.3 MHz output to drive the Sound Head of the Applicator. The Ultrasound Board is accessed through the proprietary bus by the Control Board. It can provide current and voltage information about the ultrasound output of the board. The calibration data for the Sound Head is passed through the Ultrasound Board from the Applicator to the Control Board. By storing the calibration data in the Applicator, there is no calibration necessary for the Ultrasound Board and any calibrated Chattanooga Group Vectra Genisys, Intellect Legend XT, or Intellect Vet Ultrasound Applicator can be connected and operated to provide accurate coupling and output.

1.6 USER INTERFACE AND ACCESSORIES

The LCD display panel provides the operator visible feedback in the way of menu choices. Pressing of the menu buttons makes selections from the menus. The control board interprets these user inputs and responds accordingly. Audible feedback is given as well for events such as key presses and end of treatment.

The control board accesses the Patient Data Card, sEMG Data Card and MMC Card via an on board Reader/Writer Interface. The voltage necessary to operate the reader is provided by the 100 Watt Power Supply and is regulated by the Control Board.

A. Channel 3/4 Electrotherapy Module

The Channel 3/4 Electrotherapy Module creates all muscle stimulation output for Channels 3 and 4. The Channel 3/4 Electrotherapy Module is interfaced with the System via a ribbon cable which supplies power and facilitates communication between the stim board and control board of the system. All waveforms available to channels 1 and 2 are available to channels 3 and 4 via the system software. No additional software is required for full functionality of the module.

1.6 USER INTERFACE AND ACCESSORIES (CONTINUED)

B. NiMH Battery Module

The NiMH Battery Module incorporates two Nickel Metal Hydride (NiMH) Battery packs and a PC Board. The PC Board monitors the Charge Level of the Batteries. The Batteries supply 24 VDC to the system which is then distributed to the respective pcb's through the system power supply. The Battery Module is interfaced with the system via a ribbon cable that facilitates communication with the Control Board and delivery of power to a Two Channel Electrotherapy or Combination Therapy System. When the Therapy System is connected to a Mains Power Supply via the Power Cord, the NiMH Battery Module will charge. Once the Module is fully charged the software will stop the charging process eliminating the possibility of overcharging. Battery power is used only when the Therapy System is not connected to a Mains Power Supply.

C. Laser Module and Applicators (Genisys and Intelect Vet Therapy Systems ONLY)

The Laser Module utilizes a PC Board to communicate with the Control Board via a ribbon cable. The Laser Module supplies the power required for each Laser Applicator through the Laser Applicator Cable to PC Boards mounted within the Applicator housing. All Calibration Data for the Applicators is stored on board the respective Applicator. Each Applicator incorporates a lens that is instrumental in delivery of the laser radiation to the patient. The Laser applicators are classified as Class 3B Laser products and are capable of up to 1440 nm of laser radiation in the infrared spectrum. Approved eye protection must be worn by all persons in the vicinity when the Laser is on. The Therapy System incorporates and demands entry of a unique PIN before operation of the Laser Applicators is allowed by the Therapy System. The Module also incorporates a Therapy Room Door Lockout Jack to accommodate a lockout switch that would prevent operation of the Laser Applicators should the lockout safety device be breached by persons entering or exiting the therapy room. Purchase and installation of the Lockout Device is the responsibility of the facility or clinic.

D. sEMG Module (Genisys Therapy Systems ONLY)

The Surface Electromyography (sEMG) Module utilizes a PC board to communicate to the Stim and Control Boards via direct PC Board Contacts. The sEMG module reads and transmits muscle activity through lead wires and electrodes. The sEMG Module communicates muscle activity data to the Control Board which can store the data on an sEMG Data Card via the on board Card Reader/Writer for viewing on a PC in graph form via the optional Chattanooga Group Patient Data Management System (PDMS) Software and Card Reader.

E. Operator Remote Control

The Operator Remote Control is just as its name indicates and incorporates a PC Board. The Channel 1/2 Operator Remote Control is interfaced with the Therapy System through its unique connector on the front of the Therapy System and the Channel 3/4 Electrotherapy Module. The Operator Remote Control communicates with the Stim Board(s) to the Control Board for the administration of Manual Stim Therapy only.

F. Therapy System Cart

The Therapy System Cart is designed for use with the Chattanooga Group Therapy Systems only. The cart alone provides mobility to the Therapy System and storage of necessary accessories and supplies used in conjunction with the Therapy System.

2.1 PRECAUTIONARY DEFINITIONS

The precautionary instructions found in this section and throughout this manual are indicated by specific symbols. Understand these symbols and their definitions before operating this equipment. The definition of these symbols are as follows:

Caution



Text with a "CAUTION" indicator will explain possible safety infractions that could have the potential to cause minor to moderate injury or damage to equipment.

Warning



Text with a "WARNING" indicator will explain possible safety infractions that will potentially cause serious injury and equipment damage.

Danger



Text with a "DANGER" indicator will explain possible safety infractions that are imminently hazardous situations that would result in death or serious injury.

Dangerous Voltage



Text with a "DANGEROUS VOLTAGE" indicator serves to inform the technician of possible hazards resulting in the electrical charge disbursement from certain components if handled or serviced improperly.

Laser



Text with a "LASER" indicator will explain possible safety infractions that are imminently hazardous situations that would result serious injury to eyes or blindness.

Corrosive



Text with a "CORROSIVE" indicator will explain possible safety infractions if the chemical components of the battery are exposed to air, skin, or other materials.

Laser Eye Protection



Text with a "LASER EYE PROTECTION" indicator will explain possible safety infractions that could cause serious eye injury or blindness if the eyes are directly or reflectively exposed to Laser Radiation.

Spontaneous Combustion



Text with a "SPONTANEOUS COMBUSTION" indicator will explain possible safety infractions that could create conditions for a Spontaneous Combustion if the material is mishandled and not disposed of properly.

Biohazardous Materials



Text with a "BIOHAZARD" indicator serves to inform the user of possible hazards resulting in improper handling of components and accessories that have come in contact with bodily fluids.

Non-Ionizing Electromagnetic Radiation



Text with a "NON-IONIZING ELECTROMAGNETIC RADIATION" indicator informs the user of possible hazards resulting from elevated, potentially dangerous, levels of non-ionizing radiation.

Note

Throughout this manual "NOTE" may be found. These Notes are helpful information to aid in the particular area or function being described.

2.2 PRECAUTIONARY INSTRUCTIONS

CAUTION

- Read, understand, and practice the precautionary and operating instructions. Know the limitations and hazards associated with using any laser device. Observe the precautionary and operational decals placed on the unit.
- Do not operate this unit when connected to any unit other than Chattanooga Group devices.
- Do not operate this unit in an environment where other devices are being used that intentionally radiate electromagnetic energy in an unshielded manner. Portable and mobile RF communications equipment can affect Medical Electrical Equipment.
- The Laser System should be routinely checked before each use to determine that all controls function normally; especially that the dosage control properly adjusts the intensity of the laser output in a stable manner. Also, determine that the treatment time control actually terminates the laser output when the timer reaches zero.
- Ultrasound should be routinely checked before each use to determine that all controls function normally, especially that the intensity control does properly adjust the intensity of the ultrasonic power output in a stable manner. Also, determine that the treatment time control does actually terminate ultrasonic power output when the timer reaches zero.
- DO NOT use sharp objects such as a pencil point or ballpoint pen to operate the buttons on the control panel as damage may result.
- Use of controls or adjustments or performance of procedures other than those specified herein may result in hazardous exposure to laser energy.
- Handle all Applicators with care. Inappropriate handling of the Laser Applicator may adversely affect its characteristics.
- Inspect Laser Applicator, Lenses, Cables, and associated connectors before each use. Do not use a damaged or otherwise compromised Laser Applicator.
- This unit should be operated, transported and stored in temperatures between 59° F and 104° F (15° C and 40° C), with Relative Humidity ranging from 30%-60%.
- Where the integrity of the external protective earth conductor arrangement is in doubt, equipment shall be operated from its internal electrical power source.
- DO NOT permit any foreign materials or liquids to enter the unit. Take care to prevent any foreign materials including, but not limited to, inflammables, water, and metallic objects from entering the unit. These may cause unit damage, malfunction, electrical shock, fire, or personal injury.
- Before each use, inspect Ultrasound Applicator for cracks, which may allow the ingress of conductive fluid.
- Inspect all cables and associated connectors before each use.
- This equipment generates, uses and can radiate radio frequency energy and, if not installed and used in accordance with the instructions, may cause harmful interference to other devices in the vicinity. However, there is no guarantee that interference will not occur in a particular installation. Harmful interference to other devices can be determined by turning this equipment on and off. Try to correct the interference using one or more of the following: reorient or relocate the receiving device, increase the separation between the equipment, connect the equipment to an outlet on a different circuit from that to which the other device(s) are connected and consult the factory field service technician for help.

CAUTION

- The Vectra Genisys Therapy System, the Intelect Legend XT Therapy System and the Intelect Vet Therapy System are not designed to prevent the ingress of water or liquids. Ingress of water or liquids could cause malfunction of internal components of the system and therefore create a risk of injury to the patient.
- Nylatex® Wraps contain dry natural rubber and may cause allergic reactions in patients with allergies to latex.
- Use of parts or materials other than Chattanooga Group's can degrade minimum safety.

WARNING

- U.S.A. Federal Law restricts these devices to sale by, or on the order of, a physician or licensed practitioner. This device should be used only under the continued supervision of a physician or licensed practitioner.
- Make certain the unit is electrically grounded by connecting only to a grounded electrical service receptacle conforming to the applicable national and local electrical codes.
- This device should be kept away from children.
- Care must be taken when operating this equipment around other equipment. Potential electromagnetic or other interference could occur to this or to the other equipment. Try to minimize this interference by not using other equipment in conjunction with it.
- This equipment is not designed to prevent the ingress of water or liquids. Ingress of water or liquids could cause malfunction of internal components of the system and therefore create a risk of injury to the patient.
- Do not drop the applicator or unit on hard surfaces. Do not cool an overheated applicator with ice water or ice packs. Do not allow the applicator to reach maximum temperatures repeatedly. Do not submerge the applicator or unit in water. All of these conditions will damage the applicator and unit. Damage resulting from these conditions is not covered under the warranty.
- The safety of TENS waveforms for use during pregnancy or birth has not been established.
- TENS is not effective for pain of central origin. (This includes headache.)
- TENS should be used only under the continued supervision of a physician or licensed practitioner.
- TENS waveforms have no curative value.
- TENS is a symptomatic treatment, and as such, suppresses the sensation of pain which would otherwise serve as a protective mechanism.
- Electronic monitoring equipment (such as ECG monitors and ECG alarms) may not operate properly when TENS stimulation is in use.
- In the event that an Error message or Warning appears beginning with a 2 or 3, immediately stop all use of the system and contact the dealer or Chattanooga Group for service. Errors and Warnings in these categories indicate an internal problem with the system that must be tested by Chattanooga Group or a Field Service Technician certified by Chattanooga Group before any further operation or use of the system. Use of a system that indicates an Error or Warning in these categories may pose a risk of injury to the patient, user or cause extensive internal damage to the system.

2- SAFETY PRECAUTIONS

2.2 PRECAUTIONARY INSTRUCTIONS (CONTINUED)



WARNING

- Use of controls or adjustments or performance of procedures other than those specified herein may result in hazardous exposure to ultrasonic energy.
- Before administering any treatment to a patient you should become acquainted with the operating procedures for each mode of treatment available, as well as the indications, contraindications, warnings and precautions. Consult other resources for additional information regarding the application of Electrotherapy and Ultrasound.
- To prevent electrical shock, disconnect the unit from the power source before attempting any maintenance procedures.
- Keep electrodes separated during treatment. Electrodes in contact with each other could result in improper stimulation or skin burns.
- Long term effects of chronic electrical stimulation are unknown.
- Stimulation should not be applied over the anterior neck or mouth. Severe spasm of the laryngeal and pharyngeal muscles may occur and the contractions may be strong enough to close the airway or cause difficulty in breathing.
- Stimulation should not be applied transthoracically in that the introduction of electrical current into the heart may cause cardiac arrhythmia.
- Stimulation should not be applied over swollen, infected, and inflamed areas or skin eruptions, e.g., phlebitis, thrombophlebitis, varicose veins, etc.
- Stimulation should not be applied over, or in proximity to, cancerous lesions.
- Output current density is related to electrode size. Improper application may result in patient injury. If any question arises as to the proper electrode size, consult a licensed practitioner prior to therapy session.
- The Vectra Genisys Therapy System optional modules and associated accessories are designed for use only with the Chattanooga Group Vectra Genisys Electrotherapy and Combination Therapy Systems.
- Remove the Ultrasound or Laser Applicator by pulling the cable connector only. DO NOT remove by pulling the cable.



DANGER









- Stimulus delivered by the TENS waveforms of this device, in certain configurations, will deliver a charge of 25 microcoulombs (µC) or greater per pulse and may be sufficient to cause electrocution. Electrical current of this magnitude must not flow through the thorax because it may cause a cardiac arrhythmia.
- Patients with an implanted neurostimulation device must not be treated with or be in close proximity to any shortwave diathermy, microwave diathermy, therapeutic ultrasound diathermy or laser diathermy anywhere on their body. Energy from diathermy (shortwave, microwave, ultrasound and laser) can be transferred through the implanted neurostimulation system, can cause tissue damage, and can result in severe injury or death. Injury, damage or death can occur during diathermy therapy even if the implanted neurostimulation system is turned "off"
- Handle, clean and dispose of components and accessories that have come in contact with bodily fluids according to National, Local and Facility rules, regulations and procedures.





DANGER

- 
 - DO NOT connect the unit to an electrical supply without first verifying that the power supply is the correct voltage. Incorrect voltage may cause unit damage, malfunction, electrical shock, fire, or personal injury. Your unit was constructed to operate only on the electrical voltage specified on the Voltage Rating and Serial Number Plate. Contact your dealer if the unit is not properly rated.
- 
 - When the unit is on, not all wavelengths are visible to the naked eye. Therefore, when performing any operational or functional check, make certain all persons in the vicinity of the laser wear Chattanooga Group laser protective eyewear.
- 
 - DO NOT point the laser beam directly into human or animal eyes. The lens of the eye does not detect the invisible, coherent laser beams, potentially resulting in permanent retinal damage.
- 
 - Class 3B Lasers are considered an acute hazard to the skin and eyes from direct radiation. Eye injury will occur if laser is viewed directly or from specular reflection. Eye protection is required for all persons in the treatment area.
- 
 - Power Supplies retain High Voltage!
- 
 - NiMH batteries contain Class E corrosive materials. In the event of battery cell rupture or leakage, handle battery module wearing neoprene or natural rubber gloves. Contents of a ruptured or leaking battery can cause respiratory irritation. Hypersensitivity to nickel can cause allergic pulmonary asthma. Contents of cell coming in contact with skin can cause skin irritation and chemical burns.
- 
 - Never, under any circumstances, open the battery cells. Should an individual cell from a battery become disassembled, spontaneous combustion of the negative electrode is possible. There can be a delay between exposure to air and spontaneous combustion.
- Charge the Battery Module according to the instructions found in this manual. Never attempt to charge the Battery Module on any other charging mechanism.
 - Use the Battery Module only with the Vectra Genisys Therapy Systems.
 - Do not reverse the polarity of the Battery Module. Doing so can increase the individual cell temperature and cause cell rupture or leakage.
 - Never dispose of Battery Module in fire. Never short circuit the battery. The battery may explode, ignite, leak or get hot causing serious personal injury.
 - Dispose of NiMH batteries according to national, state and local codes and regulations.

DANGER

VISIBLE AND INVISIBLE LASER RADIATION.

AVOID DIRECT EXPOSURE TO BEAM.

CLASS 3B LASER PRODUCT



3.1 VECTRA GENISYS, INTELECT LEGEND XT AND INTELECT VET THERAPY SYSTEMS

A. Vectra Genisys, Intellect Legend XT and Intellect Vet Therapy Systems

The nomenclature graphic below, **Figure 3.1**, locates the major components of an Vectra Genisys, Intellect Legend XT and Intellect Vet two channel combination therapy system equipped with the following: Channel 3/4 Electrotherapy Module, *sEMG Module, and Therapy System Cart.

Refer to the respective pages of this section for specific nomenclature of the optional modules.

* Genisys Therapy Systems ONLY



FIGURE 3.1

3.1 VECTRA GENISYS, INTELECT LEGEND XT AND INTELECT VET THERAPY SYSTEMS (CONTINUED)

B. Vectra Genisys, Intelect Legend XT and Intelect Vet Combination Therapy Systems

The nomenclature graphics below, **Figure 3.2**, indicate the general locations of the exterior components of the Two Channel Vectra Genisys, Intelect Legend XT or the Intelect Vet Combination Therapy Systems.

Know the components and their functions before performing any operation of or service to the Vectra Genisys, Intelect Legend XT or the Intelect Vet Two Channel Combination Therapy Systems.



FIGURE 3.2

- | | |
|---|---|
| <ol style="list-style-type: none"> 1. Screen Contrast Control (Not functional on color Systems) 2. System Power On/Off Switch 3. Technical Maintenance Port 4. Main Power Cord 5. Rear Access Panel 6. Two Channel Combo System 7. Ultrasound Applicator (5cm² shown) Combo Systems Only 8. User Interface (Screen and Buttons) 9. Front Access Panel 10. Patient Data Card and sEMG Data Card access port | <ol style="list-style-type: none"> 11. Multimedia Card (MMC) access port 12. Front Access Panel Lanyard- When reinstalling the Front Access Panel, make certain the Lanyard does not become kinked 13. Channel 1/2 Operator Remote Control Connector 14. Patient Interrupt Switch Connector 15. Channel 1 Lead Wire Connector 16. Channel 2 Lead Wire Connector 17. Microcurrent Probe Connector 18. Ultrasound Applicator Connector 19. Therapy System to Module Ribbon Cable (not shown) |
|---|---|

3.1 VECTRA GENISYS, INTELECT LEGEND XT AND INTELECT VET THERAPY SYSTEMS (CONTINUED)

C. Vectra Genisys, Intellect Legend XT and Intellect Vet Electrotherapy Systems

The nomenclature graphics below, **Figure 3.3**, indicate the general locations of the exterior components of the Two Channel Vectra Genisys, Intellect Legend XT or the Intellect Vet Two Channel Electrotherapy Systems.

Know the components and their functions before performing any operation of or service to the Vectra Genisys, Intellect Legend XT or the Intellect Vet Two Channel Electrotherapy Systems.

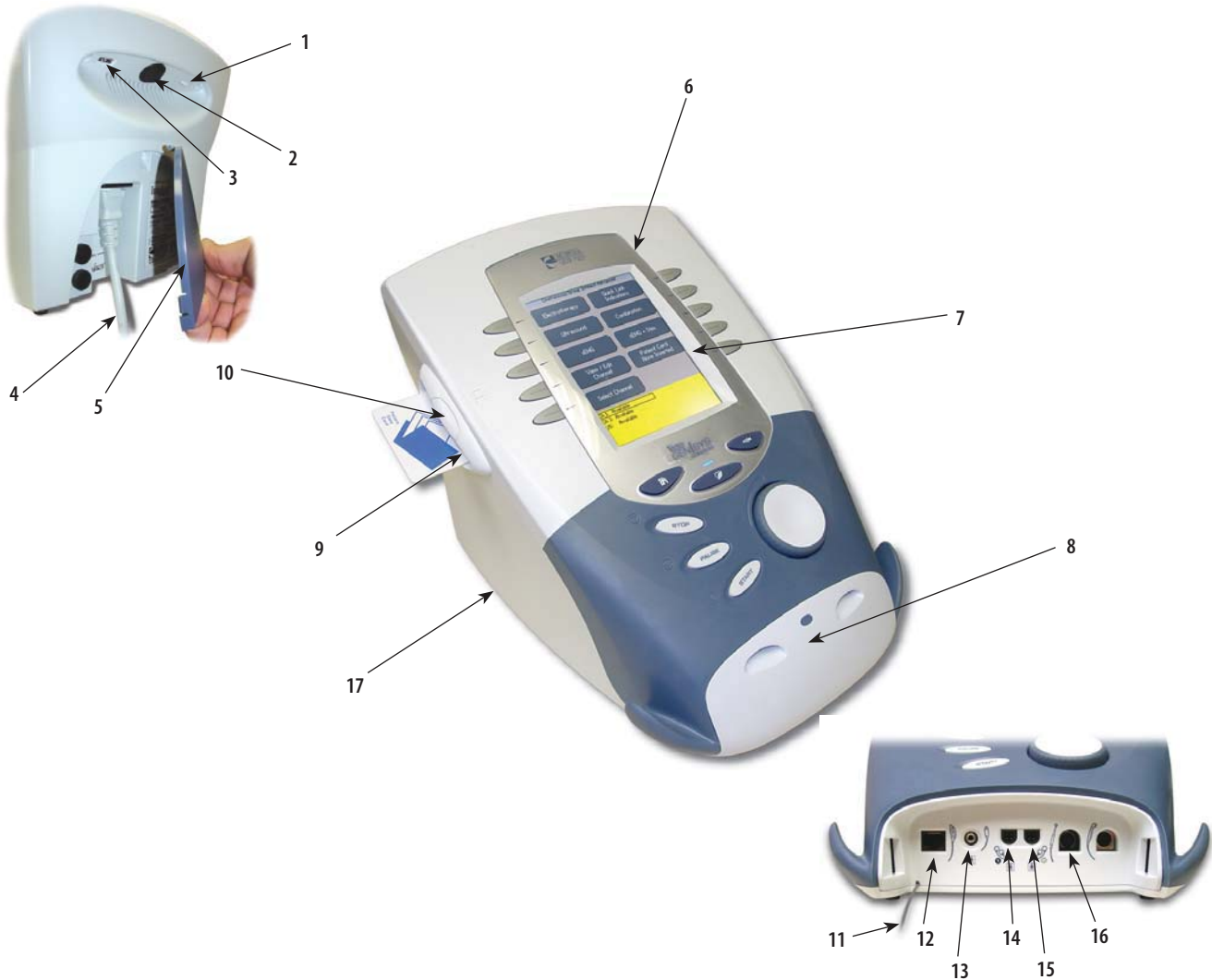

FIGURE 3.3

- | | |
|--|--|
| <ol style="list-style-type: none"> 1. Screen Contrast Control (Not functional on Color Systems) 2. System Power On/Off Switch 3. Technical Maintenance Port 4. Main Power Cord 5. Rear Access Panel 6. Two Channel Electrotherapy System 7. User Interface (Screen and Buttons) 8. Front Access Panel 9. Patient Data Card and sEMG Data Card access port | <ol style="list-style-type: none"> 10. Multimedia Card (MMC) access port 11. Front Access Panel Lanyard- When reinstalling the Front Access Panel, make certain the Lanyard does not become kinked 12. Channel 1/2 Operator Remote Control Connector 13. Patient Interrupt Switch Connector 14. Channel 1 Lead Wire Connector 15. Channel 2 Lead Wire Connector 16. Microcurrent Probe Connector 17. Therapy System to Module Ribbon Cable (not shown) |
|--|--|

3.1 VECTRA GENISYS, INTELECT LEGEND XT AND INTELECT VET THERAPY SYSTEMS (CONTINUED)

D. Vectra Genisys, Intellect Legend XT and Intellect Vet Channel 3/4 Electrotherapy Module

The nomenclature graphics below, **Figure 3.4**, indicate the general locations of the exterior components of the Vectra Genisys, Intellect Legend XT and Intellect Vet Therapy Systems Channel 3/4 Electrotherapy Module.

Know the components and their functions before performing any operation of or service to the Vectra Genisys, Intellect Legend XT and Intellect Vet Therapy Systems Channel 3/4 Electrotherapy Module.

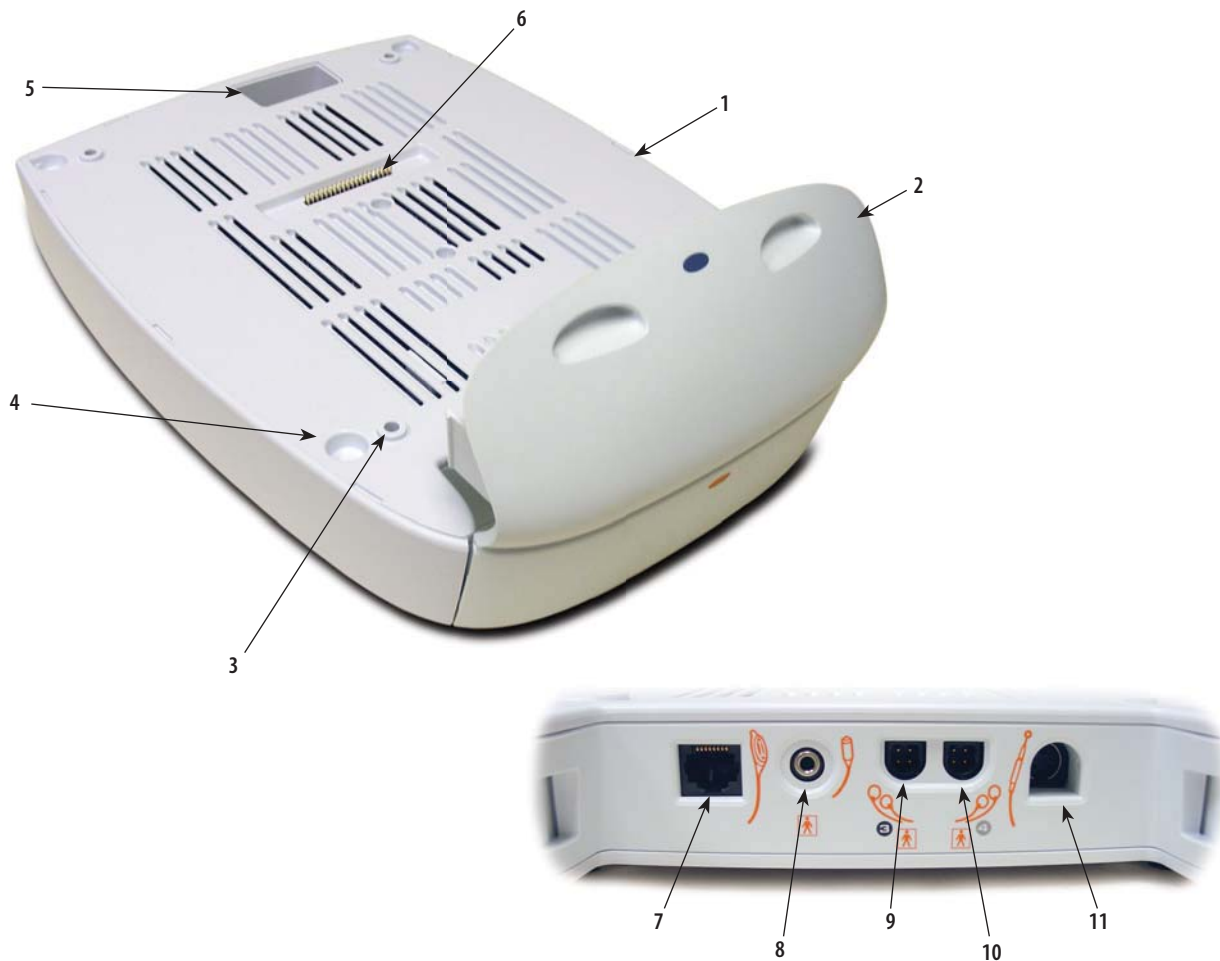

FIGURE 3.4

1. Two (2) Channel Electrotherapy Module
2. Extended Front Access Panel
3. Module to System Mounting Holes
4. Module to System Feet Alignment Indents
5. Power Cord Routing Port
6. Module to System Connector
7. Operator Remote Control Connector
8. Patient Interrupt Switch Connector
9. Channel 3 Lead Wire Connector
10. Channel 4 Lead Wire Connector
11. Microcurrent Probe Connector

Also Included:

- Four 4mm X 20mm mounting screws
- Channel 3 and 4 Lead Wires
- Sample of Dura-Stick™ II electrodes

NOTE:

The Channel 3/4 Electrotherapy Module is not operable unless it is properly connected to a Vectra Genisys, Intellect Legend XT or an Intellect Vet Therapy System.

3.1 VECTRA GENISYS, INTELECT LEGEND XT AND INTELECT VET THERAPY SYSTEMS (CONTINUED)

E. Vectra Genisys, Intellect Legend XT and Intellect Vet NiMH Battery Module

The nomenclature graphic below, **Figure 3.5**, indicates the general locations of the exterior components of the Vectra Genisys, Intellect Legend XT and Intellect Vet Systems NiMH Battery Module.

Know the components and their functions before performing any operation of or service to the Vectra Genisys, Intellect Legend XT and Intellect Vet Therapy Systems NiMH Battery Module.



FIGURE 3.5

1. NiMH Battery Module
2. Extended Front Access Panel
3. Module to System Mounting Holes
4. Module to System Feet Alignment Indents
5. Power Cord Routing Port
6. Module to System Connector

NOTE:

The NiMH Battery Module is not operable unless it is properly connected to an Vectra Genisys, Intellect Legend XT, or Intellect Vet Therapy System.

3- NOMENCLATURE

3.1 VECTRA GENISYS, INTELECT LEGEND XT AND INTELECT VET THERAPY SYSTEMS (CONTINUED)

F. Vectra Genisys and Intellect Vet Laser Module

The nomenclature graphic below, **Figure 3.6**, indicates the general locations of the exterior components of the Vectra Genisys and Intellect Vet Therapy System Laser Module.

Know the components and their functions before performing any operation of or service to the Therapy System Laser Module.



FIGURE 3.6

- 1. Laser Module
- 2. Extended Front Access Panel
- 3. Module to System Mounting Holes
- 4. Module to System Feet Alignment Indents
- 5. Power Cord Routing Port
- 6. Module to System Header
- 7. Patient Interrupt Switch (Optional)
- 8. Therapy Room Door Lockout Jack
- 9. Point Locator (for use with Single Applicator Laser Applicators)
- 10. Laser Applicator



NOTE:

The Laser Module is not operable unless it is properly connected only to its Therapy System.

NOTE:

No Field Service is applicable to the Laser Module or Laser Applicators. All Laser Modules and Applicators suspected to require service or calibration must be sent to the factory.

! DANGER

-  • DO NOT point the laser beam directly into human or animal eyes. The lens of the eye does not detect the invisible, coherent laser beams, potentially resulting in permanent retinal damage.
-  • Class 3B Lasers are considered an acute hazard to the skin and eyes from direct radiation. Eye injury will occur if laser is viewed directly or from specular reflection. Laser protective eyewear is required for all persons in the treatment area.
-  • Approved Laser protective eyewear must be worn at all times by all persons in the vicinity when the Laser is On.

3- NOMENCLATURE

3.1 VECTRA GENISYS, INTELECT LEGEND XT AND INTELECT VET THERAPY SYSTEMS (CONTINUED)

G. Vectra Genisys and Intellect Vet Laser Applicators

The nomenclature graphics below, **Figure 3.7**, indicate the general locations of the exterior components of the Vectra Genisys and Intellect Vet Therapy System Laser Applicators.

Know the components and their functions before performing any operation of or service to the Vectra Genisys and Intellect Vet Therapy System Laser Therapy System Laser Applicators.



FIGURE 3.7



1. Laser On LED
2. Laser Applicator On/Off Button
3. Single Diode Applicator Housing
4. LED Cluster Applicator Housing
5. Laser Cluster Applicator Housing
6. Laser Aperture Lens
7. Laser Aperture

NOTE:

The Laser Applicators are not operable unless they are connected to its Therapy Systems only via the Laser Module.

No Field Service is applicable to the Laser Module or Laser Applicators. All Laser Modules and Applicators suspected to require service or calibration must be sent to the factory.

⚠ **DANGER**

- 
 - DO NOT point the laser beam directly into human or animal eyes. The lens of the eye does not detect the invisible, coherent laser beams, potentially resulting in permanent retinal damage.
- 
 - Class 3B Lasers are considered an acute hazard to the skin and eyes from direct radiation. Eye injury will occur if laser is viewed directly or from specular reflection. Laser protective eyewear is required for all persons in the treatment area.
- 
 - Approved Laser protective eyewear must be worn at all times by all persons in the vicinity when the Laser is On.

3.1 VECTRA GENISYS, INTELECT LEGEND XT AND INTELECT VET THERAPY SYSTEMS (CONTINUED)

H. Vectra Genisys Dual Channel sEMG Module

The nomenclature graphics below, **Figure 3.8**, indicate the general locations of the exterior components of the Vectra Genisys Therapy System Dual Channel sEMG Module.

Know the components and their functions before performing any operation of or service to the Vectra Genisys Therapy System Dual Channel sEMG Module.

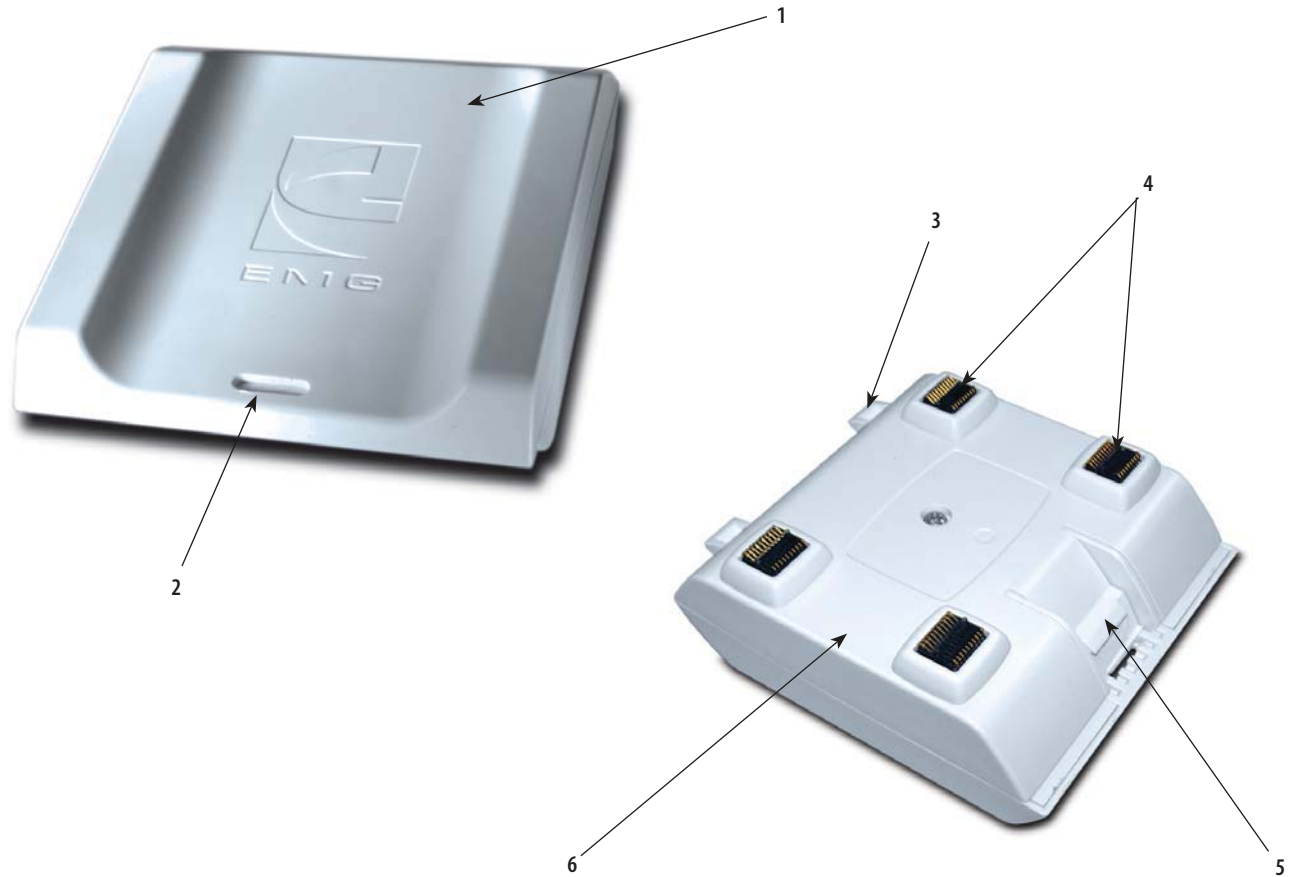

FIGURE 3.8

- 1. sEMG Module Top Housing
- 2. Module Removal Slot
- 3. Module to System Mounting Tabs
- 4. Module to System PC Board Contacts
- 5. Module to System Retaining Tab
- 6. sEMG Module Bottom Housing

NOTE:

The Vectra Genisys Dual Channel sEMG Module is not operable unless it is connected to the Vectra Genisys Therapy System.

3.1 VECTRA GENISYS, INTELECT LEGEND XT AND INTELECT VET THERAPY SYSTEMS (CONTINUED)

I. Vectra Genisys, Intellect Legend XT and Intellect Vet Therapy System Cart

The nomenclature graphics below, **Figure 3.9**, indicate the general locations of the exterior components of the Vectra Genisys, Intellect Legend XT and Intellect Vet Therapy Systems Cart.

Know the components and their functions before performing any operation of or service to the Vectra Genisys, Intellect Legend XT and Intellect Vet Therapy Systems Cart.

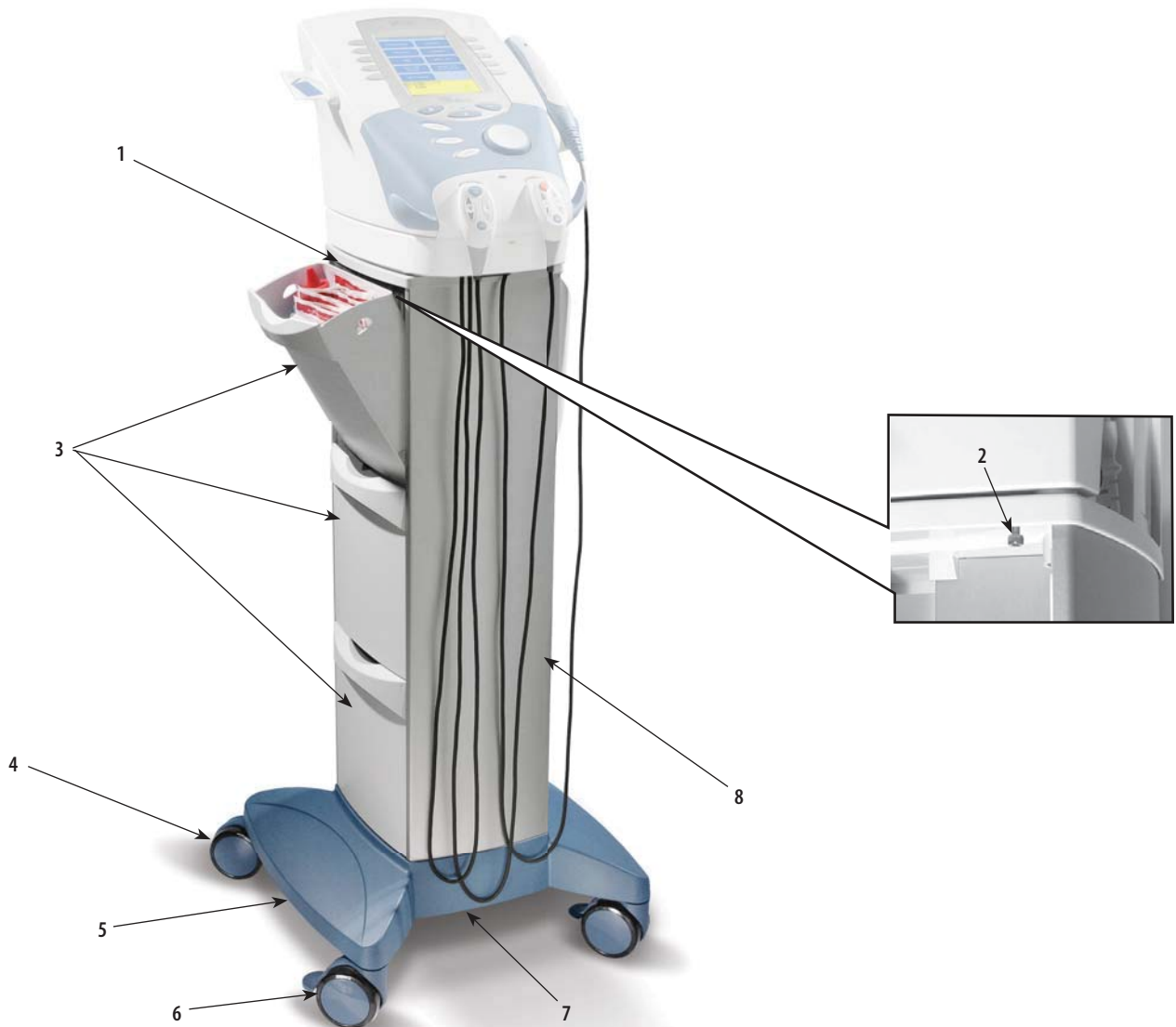

FIGURE 3.9

1. Cart Top
2. System to Cart Retaining Screw (4)
3. Storage Bins (6)
4. Cart Rear Swivel Casters
5. Cart Base
6. Cart Front Swivel, Locking Casters
7. Cart Bottom Access Plate
8. Front and Rear Cart Extrusions

3.1 VECTRA GENISYS, INTELECT LEGEND XT AND INTELECT VET THERAPY SYSTEMS (CONTINUED)

J. Vectra Genisys, Intelect Legend XT and Intelect Vet Operator Remote Control

The nomenclature graphics below, **Figure 3.10**, indicate the general locations of the exterior components of the Vectra Genisys, Intelect Legend XT and Intelect Vet Therapy Systems Operator Remote Control.

Know the components and their functions before performing any operation of or service to the Vectra Genisys, Intelect Legend XT and Intelect Vet Therapy Systems Operator Remote Control.



* Blue button for Channels 1/2 Operator Remote Control
Orange button for Channels 3/4 Operator Remote Control

FIGURE 3.10

1. Operator Remote Storage Hook
2. Treatment Pause Button
3. Channel 2 Increase Intensity Button
4. Channel 2 Decrease Intensity Button
5. Manual Stimulation Button
6. Channel 1 Decrease Intensity Button
7. Channel 1 Increase Intensity Button

NOTE:

The Vectra Genisys, Intelect Legend XT, or Intelect Vet Operator Remote Control is not operable unless it is properly connected to the its Therapy System.

Operator Remote Control Symbol Definitions



3.2 VECTRA GENISYS, INTELECT LEGEND XT AND INTELECT VET THERAPY SYSTEMS HARDWARE AND SOFTWARE SYMBOL DEFINITIONS

The symbol graphics below are found on the system as well as within the software. These symbols are defined below for the purpose of recognition and functionality when operating or performing service on an Vectra Genisys, Intellect Legend XT or Intellect Vet Therapy System, Modules, and Accessories.

Know the symbols and their definitions before performing any operation of or service to the Vectra Genisys, Intellect Legend XT or Intellect Vet Therapy Systems, Modules, or Accessories.

A. Hardware Symbols

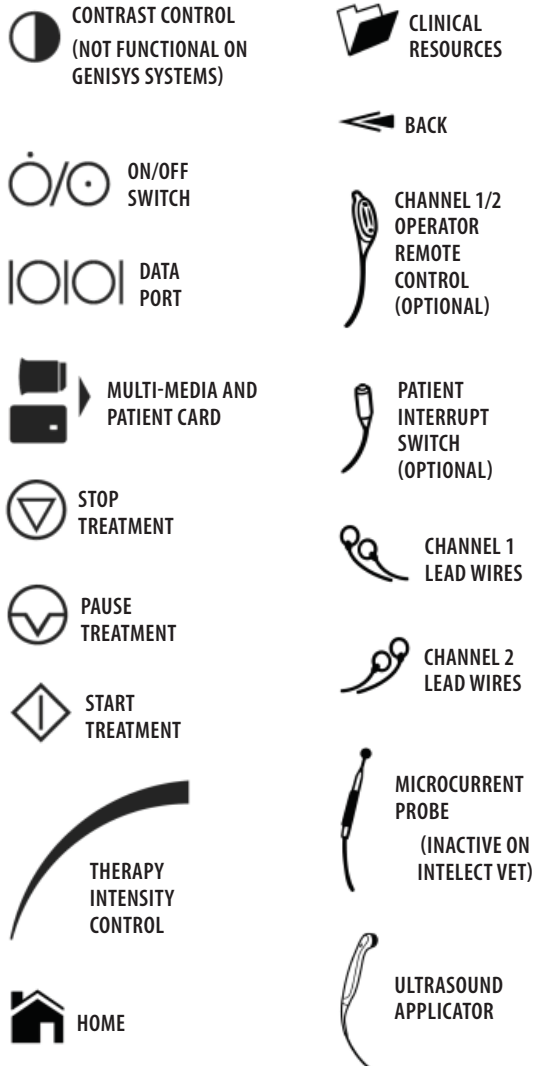

B. Software Symbols



C. Optional Accessory Symbols

1. Operator Remote Control Symbols

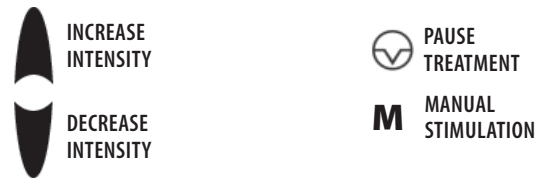

2. NiMH Battery Module Symbols



3. Channel 3/4 Electrotherapy Module Symbols

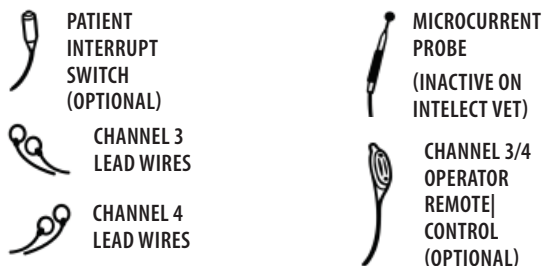

4. Laser Module Symbols (Genisys Only)



5. Laser Applicator Symbols (Genisys Only)



6. Patient Interrupt Switch



4.1 VECTRA GENISYS, INTELECT LEGEND XT AND INTELECT VET THERAPY SYSTEMS

The specifications found in this section provide physical details of the Vectra Genisys, Intelect Legend XT and Intelect Vet Therapy Systems. This section also provides waveform specifications to aid in troubleshooting.

Refer to this section when performing troubleshooting, replacement, and repair of a Vectra Genisys, Intelect Legend XT and Intelect Vet Therapy System, Modules, and Accessories.

A. Therapy Systems Physical Specifications



FIGURE 4.1

Dimensions

Height

Cart Only	33.75 in (85.7 cm)
With System	42.50 in (108 cm)
With System and Module	44.25 in (112.4 cm)

Width

.....	17 in (43.2 cm)
-------	-----------------



Depth

.....	16.25 in (41.3 cm)
-------	--------------------

Power (Combination and Electrotherapy Systems)

Input	100 - 240 V - 175 VA, 50/60 Hz
Output (Internal Power Supply)	+24, 7.3 A
Electrical Class	CLASS I
Mode of Operation	Continuous

Electrical Type

Ultrasound (Combination Systems Only) and Laser Module (Vectra Genisys and Intelect Vet Only)	TYPE B 
Electrotherapy, sEMG and Channel 3/4 Module	TYPE BF 

4- SPECIFICATIONS

4.2 ELECTROTHERAPY WAVEFORM SPECIFICATIONS

The specifications found in this section provide the necessary waveform specifications to aid in troubleshooting. A waveform graphic from an oscilloscope is also provided for clarification.

Refer to this section when performing troubleshooting, replacement, and repair of the Therapy System, Modules, and Accessories.

NOTE:

All waveforms, except High Voltage Pulsed Current (HVPC), of the Vectra Genisys, Intellect Legend XT and Intellect Vet Therapy Systems have a 200 mA current limit.

VMS™, VMS™ Burst, and all TENS waveform output intensities are measured, specified, and listed to peak, not peak to peak.

All waveforms are available on all channels.

A. IFC (Interferential) Traditional (4 Pole)- Figure 4.2 (Vectra Genisys, Intellect Legend XT, and Intellect Vet)

- Output Mode..... Electrodes
- Output Intensity..... 0-100 mA(CC)
0-100 V (CV)
- Carrier Frequency... .2,500, 4,000, and 5,000 Hz
- Beat Frequency (Sweep Off).....1-200 Hz
- Sweep Time (Fixed)..... 15 seconds
- Sweep Low Beat Frequency1-199 Hz
- Sweep High Beat Frequency.....2-200 Hz
- Vector Scan..... Off, Manual, 40%, and 100%
- Treatment Time..... 1-60 Minutes
- Mode Selection..... CC or CV*
(Intellect Vet Mode Selection Fixed- CV only)
- Available on Channels1 & 2, 3 & 4 Option

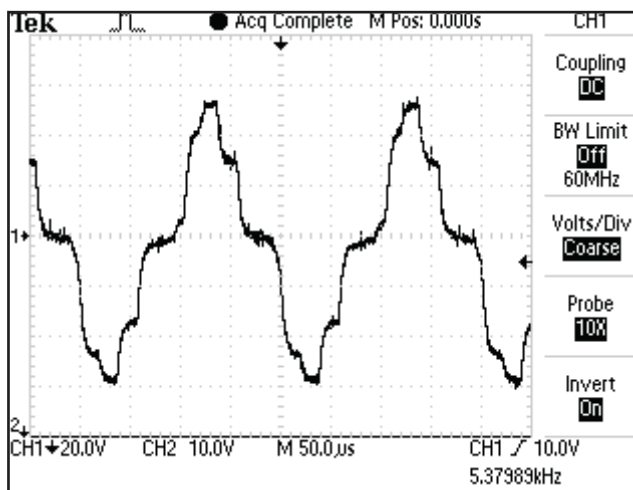

FIGURE 4.2

B. TENS- Asymmetrical Biphasic- Figure 4.3 (Vectra Genisys)

- Output Mode..... Electrodes
- Output Intensity.....0-110 mA (CC)
0-110 V (CV)
- Phase Duration20-1,000 µsec
- Frequency.....1-250 Hz
- Mode Selection..... CC or CV*
- Burst Frequency0-10 bps
- Frequency Modulation0-250 Hz
- Amplitude ModulationOff, 40%, 60%,
80%, and 100%
- Cycle Time.....4/4, 4/8, 7/7, 5/5,
4/12, 10/10, 10/20, 10/30, 10/50
- Treatment Time..... 1-60 minutes
- Available on Channels1 & 2, 3 & 4 Option

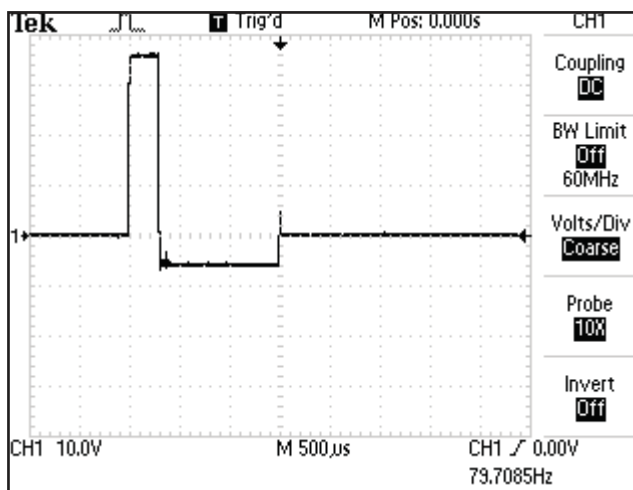

FIGURE 4.3

*CC= Constant Current
CV= Constant Voltage

DANGER

Stimulus delivered by the TENS waveforms of this device, in certain configurations, will deliver a charge of 25 microcoulombs (µC) or greater per pulse and may be sufficient to cause electrocution. Electrical current of this magnitude must not flow through the thorax because it may cause a cardiac arrhythmia.

4- SPECIFICATIONS

4.2 ELECTROTHERAPY WAVEFORM SPECIFICATIONS (CONTINUED)

C. TENS- Symmetrical Biphasic- Figure 4.4 (Vectra Genisys, and Intellect Legend XT)

- Output Mode..... Electrodes
- Output Intensity..... 0-80 mA (CC)
0-80 V (CV)
- Phase Duration.....20-1,000 μ sec
- Frequency.....1-250 Hz
- Mode Selection..... CC or CV*
- Burst Frequency.....0-10 bps
- Frequency Modulation.....0-250 Hz
- Amplitude Modulation.....Off, 40%, 60%,
80%, and 100%
- Cycle Time.....4/4, 4/8, 7/7, 5/5,
4/12, 10/10, 10/20, 10/30, 10/50
- Treatment Time..... 1-60 minutes
- Available on Channels.....1 & 2, 3 & 4 Option

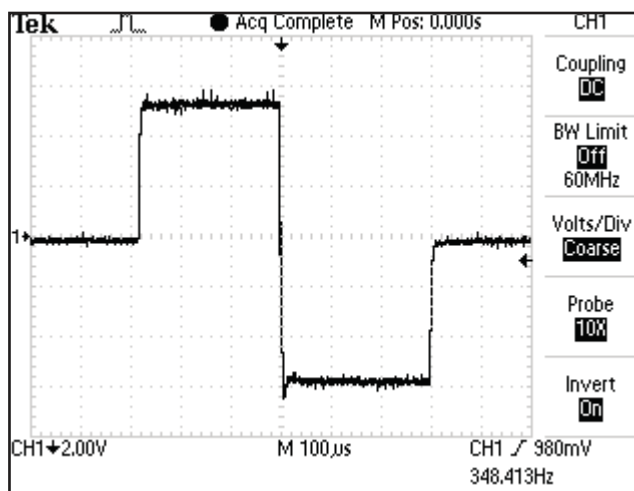

FIGURE 4.4

D. High Voltage Pulsed Current (HVPC)- Figure 4.5 (Vectra Genisys, Intellect Legend XT, and Intellect Vet)

- Output Mode..... Electrodes or Probe
- Output Intensity..... 0-500 V
- Polarity..... Positive or Negative
- Ramp..... 0.5 sec, 1 sec, 2 sec, 5 sec
- Display.....Peak Current or Volts
- Sweep..... Continuous, 80/120 pps,
1/120 pps, 1/10 pps
- Frequency..... 10-120 Hz
- Cycle Time..... Continuous, 5/5, 4/12,
10/10, 10/20, 10/30, 10/50
- Treatment Time..... 1-60 Minutes
- Anti-Fatigue..... Off or On
- Available on Channels.....1 & 2, 3 & 4 Option

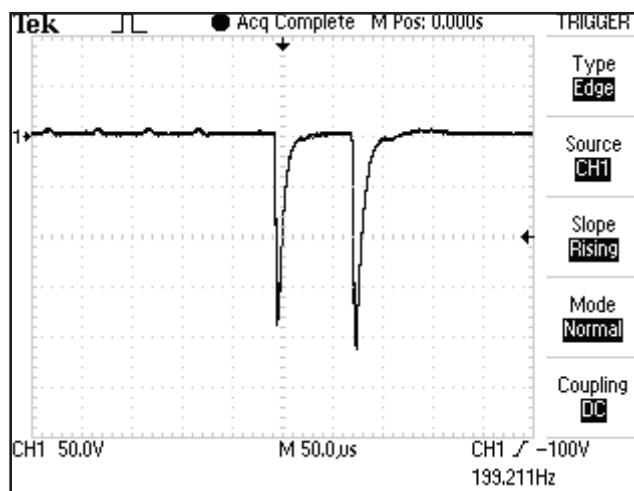

FIGURE 4.5

*CC= Constant Current
CV= Constant Voltage

4- SPECIFICATIONS

4.2 ELECTROTHERAPY WAVEFORM SPECIFICATIONS (CONTINUED)

E. VMS™ - Figure 4.6 (Vectra Genisys, and Intellect Vet)

- Output Mode..... Electrodes
- Output Intensity.....0-200 mA (CC)
0-200 V (CV)
- Channel Mode Single, Reciprocal, Co-Contract
- Phase Duration..... 20-400 µsec
- Mode Selection CC or CV*
- Anti-Fatigue Off or On
- Set Intensity . Individual Channel Intensity Setting
in Reciprocal and Co-Contract modes
- Cycle TimeContinuous, 5/5, 4/12,
10/10, 10/20, 10/30, 10/50
- Frequency 1-200 pps
- Ramp 0.5 sec, 1 sec, 2 sec, and 5 sec
- Treatment Time..... 1-60 minutes
- Available on Channels 1 & 2, 3 & 4 Option

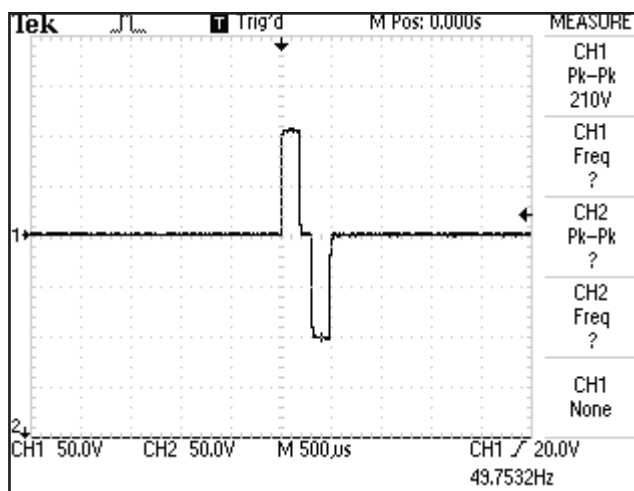

FIGURE 4.6

F. IFC (Interferential) Premodulated (2p)- Figure 4.7 (Vectra Genisys, Intellect Legend XT and Intellect Vet)

- Output Mode..... Electrodes
- Output Intensity..... 0-100 mA(CC)
0-100 V (CV)
- Carrier Frequency (Fixed) 2,500 Hz
- Beat Frequency (Sweep Off)..... 1-200 Hz
- Sweep Time (Fixed) 15 seconds
- Sweep Low Beat Frequency 1-199 Hz
- Sweep High Beat Frequency..... 2-200 Hz
- Vector Scan..... Off, Manual, 40%, and 100%
- Treatment Time..... 1-60 Minutes
- Mode Selection..... CC or CV*
(Intellect Vet Mode Selection Fixed- CC only)
- Available on Channels 1 & 2, 3 & 4 Option

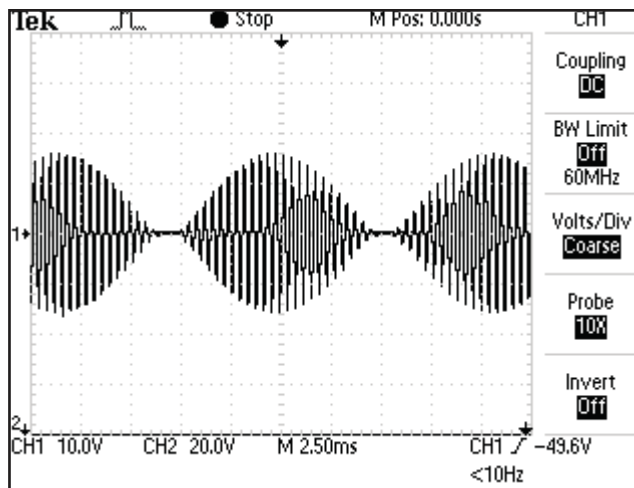

FIGURE 4.7

*CC= Constant Current
CV= Constant Voltage

4- SPECIFICATIONS

4.2 ELECTROTHERAPY WAVEFORM SPECIFICATIONS (CONTINUED)

G. Russian- Figure 4.8 (Vectra Genisys, Intellect Legend XT and Intellect Vet)

- Output Mode Electrodes
- Output Intensity.....0-100 mA (CC)
0-100 V (CV)
- Carrier Frequency (Fixed) 2,500 Hz
- Channel Mode.... Single, Reciprocal, Co-Contract
- Duty Cycle 10%, 20%, 30%, 40%, and 50%
- Mode Selection..... CC or CV*
(Intellect Vet Mode Selection Fixed- CC only)
- Anti-Fatigue..... Off or On
- Cycle Time Continuous, 5/5, 4/12,
10/10, 10/20, 10/30, 10/50
- Burst Frequency..... 20-100 bps
- Ramp 0.5, 1, 2, and 5 seconds
- Treatment Time 1-60 minutes
- Available on Channels 1 & 2, 3 & 4 Option

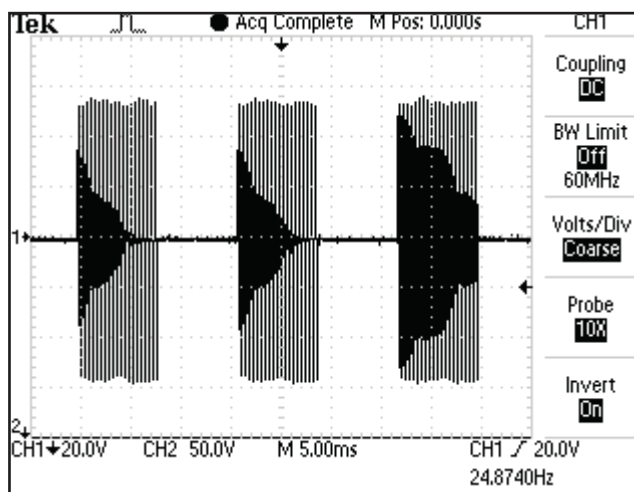

FIGURE 4.8

H. Microcurrent- Figure 4.9 (Vectra Genisys and Intellect Legend XT)

- Output Mode Electrodes or Probe
- Output Intensity..... 5-1000.0 μ A
- Polarity..... Positive, Negative, or Alternating
- Treatment Time 1-60 Minutes (Electrodes)
1-60 Seconds (Probe)
- Carrier Frequency 0.1- 1000 Hz
- Duty Cycle (Fixed) 50%
- Ramp (Fixed)..... 1 second

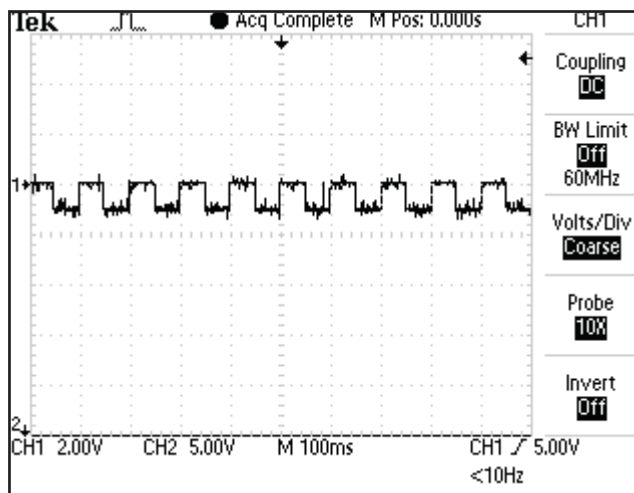

FIGURE 4.9

*CC= Constant Current
CV= Constant Voltage

4- SPECIFICATIONS

4.2 ELECTROTHERAPY WAVEFORM SPECIFICATIONS (CONTINUED)

I. VMS™ Burst- Figure 4.10 (Vectra Genisys)

- Output Mode..... Electrodes
- Output Intensity.....0-200 mA (CC)
0-200 V (CV)
- Channel Mode Single, Reciprocal, Co-Contract
- Phase Duration..... 20-400 µsec
- Mode Selection CC or CV*
- Anti-Fatigue Off or On
- Set Intensity .. Individual Channel Intensity Setting
in Reciprocal and Co-Contract modes
- Cycle Time Continuous, 5/5, 4/12,
10/10, 10/20, 10/30, 10/50
- Frequency 1-200 pps
- Ramp 0.5 sec, 1 sec, 2 sec, and 5 sec
- Treatment Time..... 1-60 minutes
- Available on Channels..... 1 & 2, 3 & 4 Option

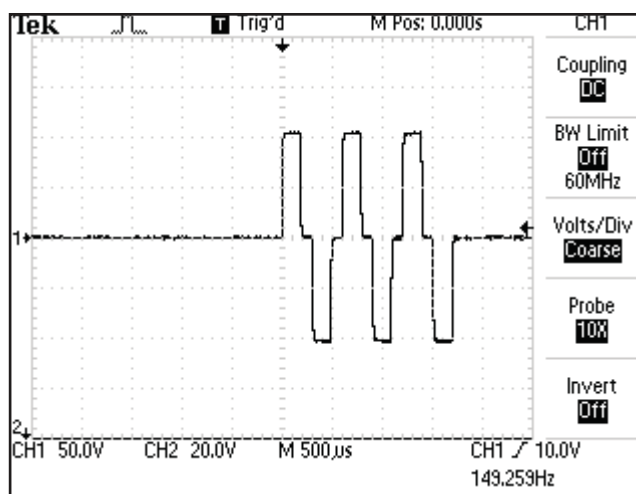

FIGURE 4.10

J. DC (Direct Current)- Figure 4.11 (Vectra Genisys)

- Output Mode Electrodes
- Output Intensity.....0-4 mA
- Polarity Reversal..... On or Off
- With Polarity Reversal On, Polarity will change
after 50% of treatment time.
- Cycle Time..... Continuous, 5/60, 10/60
- Treatment Time..... 1-10 minutes
- Mode Selection (Fixed)..... CC*
- Available on Channels..... 1 & 2, 3 & 4 Option

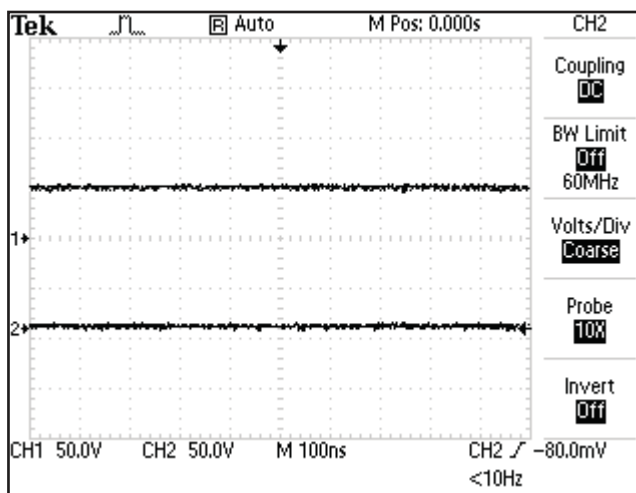

FIGURE 4.11

K. Iontophoresis- (Intelect Vet)

- Output Mode Electrodes
- Output Intensity.....0-4 mA
- Calculated Dosage 40-80 mA - Minute
- Mode Selection (Fixed)..... CC*
- Available on Channels..... 1 & 2, 3 & 4 Option

*CC= Constant Current
CV= Constant Voltage

4- SPECIFICATIONS

4.3 ULTRASOUND SPECIFICATIONS

This section provides the necessary Ultrasound Specifications to aid in troubleshooting the Vectra Genisys, Intelect Legend XT or Intelect Vet Ultrasound PC Board and Applicators.

Refer to these specifications as necessary when troubleshooting the Ultrasound PC Board and Applicators.



Ultrasound

Frequency	1 MHz, ± 5%; 3.3 MHz, ±5%
Duty Cycles	10%, 20%, 50%, and Continuous
Pulse Frequency.....	100 Hz
Pulse Duration	1 mSec, ±20%; 2 mSec, ±20%, and 5 mSec, ±20%

Output Power

10 cm² Crystal	0-20 Watts at 1 MHz and 0-10 Watts at 3.3 MHz
5 cm² Crystal.....	0-10 Watts, 1 and 3.3 MHz
2 cm² Crystal.....	0-4 Watts, 1 and 3.3 MHz
1 cm² Crystal.....	0-2 Watts 3.3 MHz Only
Amplitude	0 to 2.5 w/cm² in continuous mode, 0-3 w/cm² in pulsed modes
Output accuracy	± 20% above 10% of maximum
Temporal Peak to Average Ratios:	2:1, ± 20%, at 50% Duty Cycle 5:1, ± 20%, at 20% Duty Cycle 9:1, ± 20%, at 10% Duty Cycle
Beam Nonuniformity Ratio.....	5.0 : 1 maximum
Beam Type	Collimating
IPX0 Rating for Unit	IPX0
IPX7 Rating for Applicator	IPX7
Effective Radiating Areas	10 cm² Crystal: 6.8 cm² – 10 cm² 5 cm² Crystal: 3.5 cm²– 5 cm² 2 cm² Crystal: 1.4 cm²– 2 cm² 1 cm² Crystal: 0.7 cm² – 1 cm²

Treatment Time..... 1-30 Minutes

Head Warming Feature

The Head Warming feature of an Vectra Genisys, Intelect Legend XT or Intelect Vet Combination Therapy System utilizes Ultrasound output resulting in warming of the Sound Head to increase patient comfort.

With Head Warming enabled, ultrasound is emitted without pressing the Start button. The Applicator LED will not illuminate during the Head Warming period. US Channel will indicate "Head Warming".

Output	0 - 50% Cycling of maximum power
Frequency.....	3.3 Mhz
Sound Head Temperature	85 °F - 110 °F (29.4 °C - 43.3 °C)

4- SPECIFICATIONS

4.4 DESCRIPTION OF DEVICE MARKINGS

The markings on the Vectra Genisys Therapy System, the Intelect Legend XT Therapy System and the Intelect Vet Therapy System are your assurance of their conformity to the highest applicable standards of medical equipment safety and electromagnetic compatibility. One or more of the following markings may appear on these devices:



Listed by Intertek Testing Services NA Inc.
 Conforms to UL Standard UL/IEC/EN 60601-1, IEC/EN 60601-1-2, IEC 60601-2-5, IEC 60601-2-10
 Certified to CAN/CSA Standard C22.2 No. 601.1-M90 w/A2



EU Directive on Waste Electrical and Electronic Equipment (WEEE) ensures that product is appropriately disposed of or recycled at the end of its life.



Refer to Instruction Manual/Booklet



Equipment capable of delivering output values in excess of 10 mA r.m.s. or 10V r.m.s. averaged over any period of 5 s



Type B Equipment



Type BF Equipment



Protected Earth



Dangerous Voltage



Non-Ionizing Radiation

4- SPECIFICATIONS

4.5 LASER MODULE SPECIFICATIONS (VECTRA GENISYS AND INTELECT VET)

This section provides the necessary Laser Module and Applicator Specifications to aid in troubleshooting.

Refer to these specifications as necessary when troubleshooting the Laser Module and Applicators.



Power InputTherapy System Dependent
 Output to Laser ApplicatorsPer Applicator Requirement

NOTE:
 No Field Service is applicable to the Laser Module or Laser Applicators. All Laser Modules and Applicators suspected to require service or calibration must be sent to the factory.



DANGER

- DO NOT point the laser beam directly into human or animal eyes. The lens of the eye does not detect the invisible, coherent laser beams, potentially resulting in permanent retinal damage.
- Class 3B Lasers are considered an acute hazard to the skin and eyes from direct radiation. Eye injury will occur if laser is viewed directly or from specular reflection. Laser protective eyewear is required for all persons in the treatment area.
- Approved Laser protective eyewear must be worn at all times by all persons in the vicinity when the Laser is On.

4- SPECIFICATIONS

4.6 LASER APPLICATOR SPECIFICATIONS (VECTRA GENISYS AND INTELECT VET)

A. Single Diode Applicators



NOTE:
No Field Service is applicable to the Laser Module or Laser Applicators. All Laser Modules and Applicators suspected to require service or calibration must be sent to the factory.

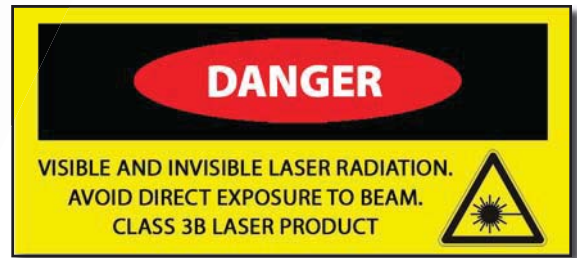

Single Diode Laser and LED Applicators					
Applicator	Wavelength (nm)	Output Power (mW)	Power Density (W/cm ²)	Contact Area (cm ²)	Diode Type
850 nm 100 mW	850	100	1.43	0.07	LASER
850 nm 200 mW	850	200	2.86	0.07	LASER
820 nm 300 mW	820	300	0.606	0.495	LASER
820 nm 500 mW	820	500	1.01	0.495	LASER

For all single diode and cluster laser and LED applicators, the expected increase in the measured quantities after manufacture added to the values measured at the time of manufacture is ±20%.

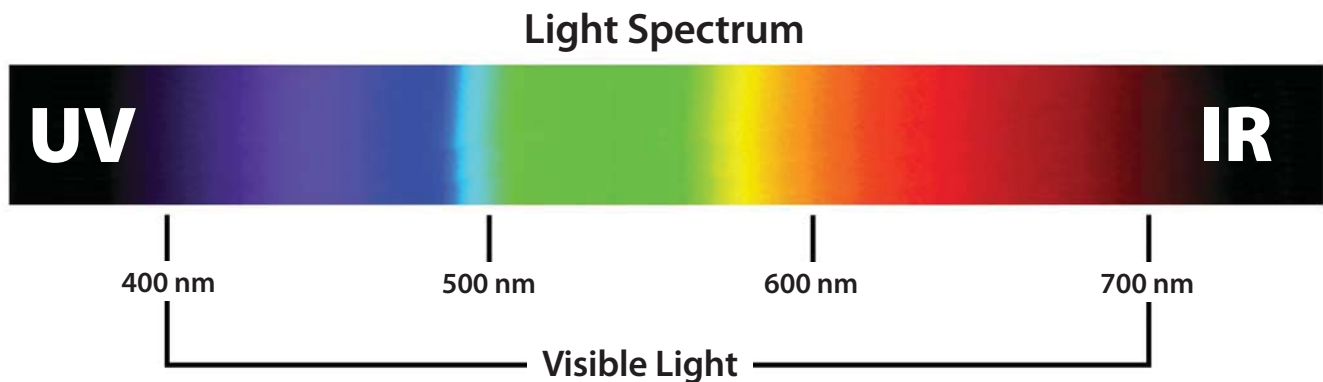

4- SPECIFICATIONS

4.6 LASER APPLICATOR SPECIFICATIONS VECTRA GENISYS AND INTELECT VET (CONTINUED)

B. 9, 13, and 19 Diode Applicators



NOTE:
No Field Service is applicable to the Laser Module or Laser Applicators. All Laser Applicators suspected to require service or calibration must be sent to the factory.

DANGER

VISIBLE AND INVISIBLE LASER RADIATION.
AVOID DIRECT EXPOSURE TO BEAM.
CLASS 3B LASER PRODUCT

9 and 13 Diode Cluster Applicators				
Applicator	Output Power (mW)	Power Density (W/cm ²)	Contact Area (cm ²)	Diode Specifications
540 mW 9 Diode Cluster	540	0.072	7.55	4- 670 nm (10 mW) LED 5- 850 nm (100 mW) LASER
1040 mW 9 Diode Cluster	1040	0.135	7.55	4- 670 nm (10 mW) LED 5- 850 nm (200 mW) LASER
415 mW 13 Diode Cluster	415	0.055	7.55	7- 670 nm (10 mW) LED 3- 850 nm (100 mW) LASER 3- 950 nm (15 mW) SLD
715 mW 13 Diode Cluster	715	0.095	7.55	7- 670 nm (10 mW) LED 3- 850 nm (200 mW) LASER 3- 950 nm (15 mW) SLD

For all Laser and LED applicators, the expected increase in the measured quantities, after manufacture, added to the values measured at the time of manufacture is ±20%.

Light Spectrum

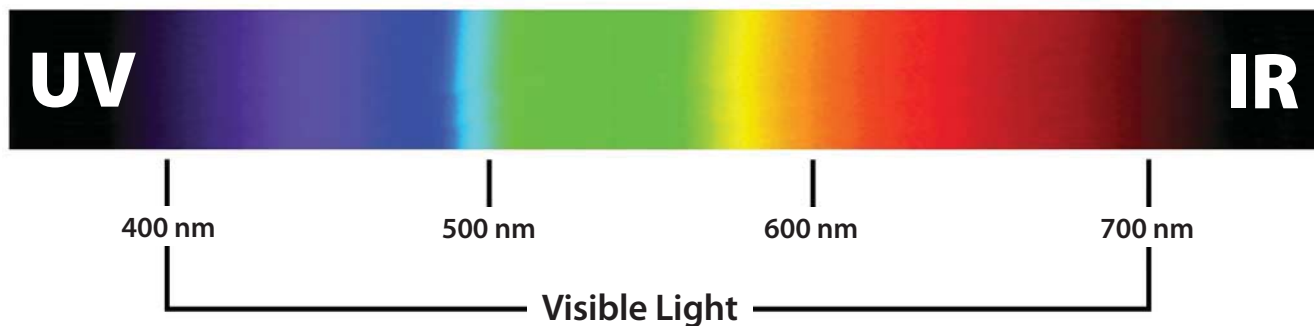

4- SPECIFICATIONS

4.6 LASER APPLICATOR SPECIFICATIONS VECTRA GENISYS AND INTELECT VET (CONTINUED)

C. 33 Diode Applicators



NOTE:
No Field Service is applicable to the Laser Module or Laser Applicators. All Laser Applicators suspected to require service or calibration must be sent to the factory.

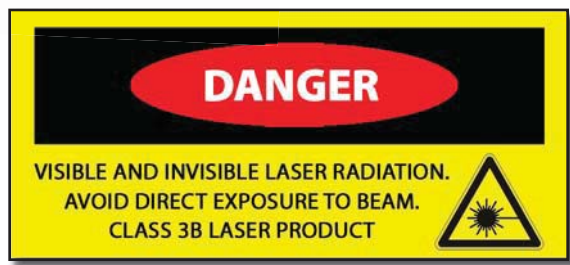

33 Diode Cluster Applicators				
Applicator	Output Power (mW)	Power Density (W/cm ²)	Contact Area (cm ²)	Diode Specifications
1440 mW 33 Diode Cluster	1440	0.046	31.2	12- 670 nm (10 mW) LED 8- 880 nm (25 mW) SLD 8- 950 nm (15 mW) SLD 5- 850 nm (200 mW) LASER

For all Laser and LED applicators, the expected increase in the measured quantities, after manufacture, added to the values measured at the time of manufacture is ±20%.

Light Spectrum

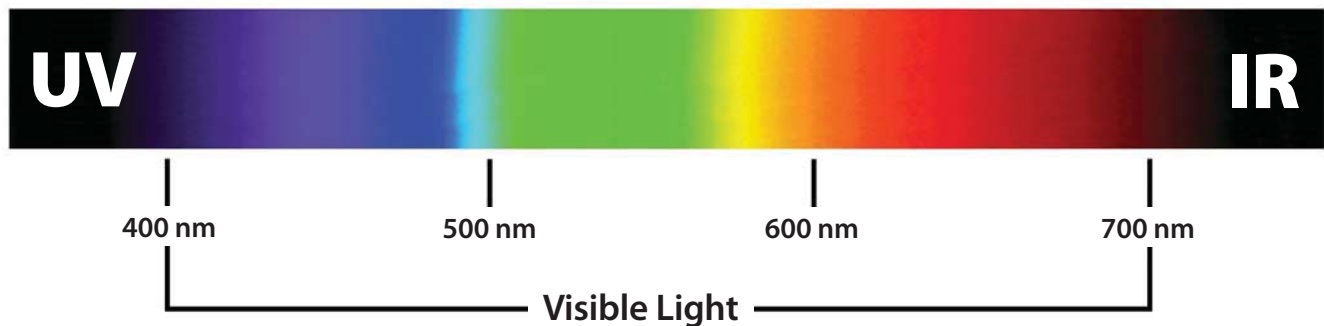

5.1 THERAPY SYSTEM ERROR MESSAGES

A. The information provided below is intended to aid in defining the Software Error Messages of the Vectra Genisys, Intellect Legend XT or Intellect Vet Therapy Systems. Once a particular Error Message is defined the information will also list probable causes and possible remedies.

No Board Level troubleshooting or Field Repair Information is or will be provided by Chattanooga Group for Field Repair of the Vectra Genisys, Intellect Legend XT or Intellect Vet Therapy System, Modules, or Accessories.

Error messages in the range of 100 to 199 are primarily user definable and remedied by following the instructions given by the Therapy System. Error messages in the ranges of 200- 299 and 300-399, require Technical Assistance.

NOTE:

No Field Service is applicable to the Laser Module or Laser Applicators. All Laser Applicators suspected to require service or calibration must be sent to the factory.

Code Number	Type Message	Probable Cause	Possible Remedies
100	Warning	Overcurrent	A. Check Electrodes and Lead Wires. Make certain Lead Wires are not damaged and are properly connected to the system. Make certain Lead Wires are properly connected to the Electrodes and that electrodes are not damaged and are making proper contact with treatment area. B. Replace Lead Wires and Electrodes
101	Warning	Shorted Lead Wires	A. Check Electrodes and Lead Wires. Make certain Lead Wires are not damaged and are properly connected to the system. Make certain Lead Wires are properly connected to the Electrodes and that electrodes are not damaged and are making proper contact with treatment area. B. Replace Lead Wires and Electrodes
102	Warning	Bad Contact Quality	A. Make certain Electrodes are making proper contact with the treatment area. B. Make certain Lead Wires are properly connected to Electrodes. C. Replace Electrodes and Lead Wires.
103	Warning	Blank Patient ID	Properly enter Patient ID. Refer to Therapy System User Manual for Patient Data Card instructions.
104	Warning	1. Blank Protocol Name 2. Blank Sequence Name	Properly enter Protocol or Sequence Name. Refer to the appropriate section of the Therapy System User Manual.
106	Warning	1. Attempting to delete factory set Sequence.	Cannot delete factory set Clinical Protocols or factory set Sequences.
107	Warning	2. Attempting to delete Clinical Protocol.	
108	Warning	Attempting to save additional User Protocols or Sequences after system memory has reached the maximum allowed (200).	Delete some User Protocols or Sequences. Refer to appropriate section of the Therapy System User Manual for instructions.
109	Warning	Attempting to access protocols or sequences and none are found in the system.	A. User Protocols- No protocols have been saved in the system. Refer to Therapy System User Manual to save User Protocols
110	Warning		B. Sequences- No User Sequences have been saved in the system. Refer to Therapy System User Manual to save Sequences.
111	Warning		
112	Warning	Ultrasound Applicator disconnected from system during treatment session.	A. Connect Ultrasound Applicator to system. B. If Ultrasound Applicator is connected, reset system by turning power switch Off and On. C. If problem persists, connect a known good Ultrasound Applicator. If problem continues, contact dealer or factory for service.
113	Warning	Attempting to perform Ultrasound treatment with no Applicator connected to the system.	A. Connect the desired Ultrasound Applicator to the system. B. If Ultrasound Applicator is connected, reset system by turning power switch Off and On. C. If problem persists, connect a known good Ultrasound Applicator. If problem continues, contact dealer or factory for service.
114	Warning	Ultrasound Applicator is not calibrated.	Attempt to use a known good Applicator. If problem continues, contact dealer or factory for service.
115	Warning	Ultrasound Applicator is too hot.	Allow Ultrasound Applicator Sound Head to cool to ambient temperature.
116	Warning	1. No Patient Data Card is inserted into the system. 2. Attempted to use an Invalid Patient Data Card.	A. Properly insert the Patient Data Card into the system port. Refer to Therapy System User Manual for new and existing Patient Data Card instructions.
117	Warning		B. Attempt to use a known good Patient Data Card. C. Make certain a Patient Data Card and not an sEMG Data Card is being used. D. If problem continues, contact dealer or factory for service.

5.1 THERAPY SYSTEM ERROR MESSAGES (CONTINUED)

Code Number	Type Message	Probable Cause	Possible Remedies
118	Warning	Attempting to save additional User Protocols or Sequences after system memory has reached the maximum allowed (200).	Delete some User Protocols or Sequences. Refer to appropriate section of the Therapy System User Manual for instructions.
119 120 121 122	Warning Warning Warning Warning	<ol style="list-style-type: none"> Attempted to read a treatment from Patient Data Card that is not a valid treatment for the system Attempted to use a Non-Patient Data Card. No Patient Data Card inserted into system port. Unknown type of smart card inserted into system. 	<ol style="list-style-type: none"> Use a Patient Data Card with proper treatment data for the system. Properly insert a Patient Data Card. Insert a known good Patient Data Card. If problem persists, insert a known good Patient Data Card. If problem continues, contact dealer or Factory for service.
123	Warning	Patient Data Card is full.	Erase Patient Data Card. Refer to Therapy System User Manual for instructions.
124	Warning	Patient Treatment Data already saved.	<ol style="list-style-type: none"> Cannot save same data again on Patient Data Card. Use a new Patient Data Card to resave data. Erase Patient Data Card and resave treatment data.
125	Warning	Multimedia Card (MMC) not in system port.	<ol style="list-style-type: none"> Properly insert the MMC card into the system port. Insert a known good MMC Card. If problem continues, contact dealer or Chattanooga Group for Service.
126	Warning	No valid channels are available for attempted treatment.	<ol style="list-style-type: none"> Complete existing treatment before attempting to start another. Reset Therapy System by turning main power switch Off and On.
127 128	Warning Warning	<ol style="list-style-type: none"> No sEMG Channels are available for treatment. No sEMG Module installed or detected by system. 	<ol style="list-style-type: none"> Wait until current treatment is complete. Reset Therapy System by turning main power switch Off and On. Make certain sEMG Module is properly installed. Refer to sEMG Module User Manual for installation instructions. Replace sEMG Module with known good sEMG Module. If problem continues, contact dealer or factory for service.
129	Warning	sEMG Data Card full.	<ol style="list-style-type: none"> sEMG Data Card faulty. Insert a known good sEMG Data Card. If problem continues, contact dealer or factory for service.
130	Warning	Another treatment is running while attempting to set up and perform a Laser Therapy treatment.	<ol style="list-style-type: none"> Allow existing treatment to complete before starting Laser Therapy. If no other treatment is running, reset Therapy System by turning main power switch Off and On.
131	Warning	Treatment Room Door Lockout is breached.	<ol style="list-style-type: none"> Make certain Treatment Room Door is completely closed. Make certain the Lockout cable is connected to the system. Replace Lockout to System cable with a known good cable. Contact department responsible for installation of the Treatment Room Door Lockout mechanism for maintenance or repair. If problem continues, send Laser Module to factory for Service.
132	Warning	Attempted to start a laser treatment but no Laser Applicator is plugged in.	<ol style="list-style-type: none"> Connect desired Laser Applicator to the system. If Applicator is connected, reset Therapy System by turning main power switch Off and On. Connect a known good Laser Applicator. If problem continues, send Laser Module to factory for Service.
133	Warning	Laser Applicator became unplugged while performing a laser treatment.	<ol style="list-style-type: none"> Connect desired Laser Applicator to the system. If Laser Applicator is connected, reset Therapy System by turning main power switch Off and On. Connect a known good Laser Applicator. If problem continues, send Laser Module to factory for Service.
134	Warning	Entered incorrect laser PIN.	<ol style="list-style-type: none"> Enter correct Laser PIN number. If problem continues, send Laser Module to factory for Service.

5.1 THERAPY SYSTEM ERROR MESSAGES (CONTINUED)

Code Number	Type Message	Probable Cause	Possible Remedies
135	Warning	Control Board Software upgrade warning.	Upgrade Control Board Software to latest version. Contact dealer or Chattanooga Group for latest software upgrade and instructions.
136	Warning	Stim Board Main Software upgrade warning.	Upgrade Stim Board Software to latest version. Contact dealer or Chattanooga Group for latest software upgrade and instructions.
137	Warning	Stim Board Main Software upgrade warning.	Upgrade Stim Board Software to latest version. Contact dealer or Chattanooga Group for latest software upgrade and instructions.
138	Warning	Ultrasound Board Software upgrade warning.	Upgrade Ultrasound Board Software to latest version. Contact dealer or Chattanooga Group for latest software upgrade and instructions.
139	Warning	Laser Board Software upgrade warning.	Upgrade Laser Board Software to latest version. Contact dealer or Chattanooga Group for latest software upgrade and instructions.
140	Warning	MMC Software upgrade warning.	Upgrade MMC Software to latest version. Contact dealer or Chattanooga Group for latest software upgrade and instructions.
141	Warning	Battery Module Software upgrade warning.	Upgrade Battery Software to latest version. Contact dealer or Chattanooga Group for latest software upgrade and instructions.
142	Warning	A Laser Protocol was selected but no Laser Module is installed on system.	Install Laser Module to Therapy System. Refer to Laser Module User Manual for installation Instructions.
143	Warning	A Laser Protocol was selected but no Laser Applicator connected to system.	<p>A. Connect proper Laser Applicator to the system.</p> <p>B. If Laser Applicator is connected, reset Therapy System by turning main power switch Off and On.</p> <p>C. Connect a known good Laser Applicator.</p> <p>D. If problem continues, send Laser Module to factory for Service.</p>
144	Warning	Wrong Laser Applicator connected to system for the protocol selected.	<p>A. Connect correct Laser Applicator to the system.</p> <p>B. If Applicator is connected, reset Therapy System by turning main power switch Off and On.</p> <p>C. Connect a known good Laser Applicator.</p> <p>D. If problem continues, send Laser Module to factory for Service.</p>
145	Warning	Patient Data Card button on Home Screen was pressed with no Patient Data Card installed into system port and no treatment currently being performed.	Properly insert a Patient Data Card, set up and perform the treatment and, save data to Patient Data Card.

5.1 THERAPY SYSTEM ERROR MESSAGES (CONTINUED)

ERROR MESSAGES REQUIRING TECHNICAL ASSISTANCE (200-299)			
Code Number	Type Message	Probable Cause	Possible Remedies
200	Error	Error reading the system Real Time Clock (RTC)	Replace Control Board
201	Error	Internal List Box Memory Error.	Reinstall software. If problem persists, replace Control Board.
202	Error	Program Control Software Allocation Memory Error	Reinstall software. If problem persists, replace Control Board.
203	Error	Error erasing Patient Data Card	Insert known good Patient Data Card. If problem persists, replace Control Board.
204	Error	Error writing to sEMG Data Card.	Insert known good sEMG Data Card. If problem persists, replace Control Board.
205	Error	MMC Card Formatting Error. (Using Tech Service Utilities)	Insert known good MMC Card. If problem persists, replace Control Board.
206	Error	Error reading MMC.	Insert known good MMC Card. If problem persists, replace Control Board.
207	Error	Error reading protocols on power up of system.	Restore default protocols. All User Protocols and Saved Sequences will be deleted permanently from the system.
208	Error	Error reading protocols.	Restore default protocols. All User Protocols and Saved Sequences will be deleted permanently from the system.
209	Error	Error writing protocol.	Restore default protocols. All User Protocols and Saved Sequences will be deleted permanently from the system.
210	Error	Error Calibrating Ultrasound Applicator.	A. Connect a known good Ultrasound Applicator. B. Replace Ultrasound Board. C. Replace Control Board.
211	Error	Error saving Calibration Data to Ultrasound Applicator.	A. Connect a known good Ultrasound Applicator. B. Replace Ultrasound Board. C. Replace Control Board.
212	Error	Ultrasound Applicator not calibrated OK Error.	A. Connect a known good Ultrasound Applicator. B. Replace Ultrasound Board. C. Replace Control Board.
213	Error	Time out error saving Ultrasound Applicator Calibration Data to Applicator.	A. Connect a known good Ultrasound Applicator. B. Replace Ultrasound Board. C. Replace Control Board.
214	Error	General Laser PC Board Error.	Send Laser Module to factory for Service.
215	Error	Laser Applicator out of calibration due to laser output being too high.	Send Laser Applicator to factory for Service.
216	Error	Laser Applicator out of calibration due to laser output being too low.	Send Laser Applicator to factory for Service.
217	Error	Laser Applicator out of Calibration Due to LED output being too high.	Send Laser Applicator to factory for Service.
218	Error	Laser Applicator out of Calibration Due to LED output being too low.	Send Laser Applicator to factory for Service.
219	Error	Error while performing a Software upgrade.	A. Turn Therapy System Off and back On. Reattempt upgrade. B. Replace the PC Board that the software is attempting to upgrade.
220	Error	Error while performing a Software upgrade.	A. Turn Therapy System Off and back On. Reattempt upgrade. B. Replace the PC Board that the software is attempting to upgrade.
221	Error	Error while performing a Software upgrade.	A. Turn Therapy System Off and back On. Reattempt upgrade. B. Replace the PC Board that the software is attempting to upgrade.
222	Error	Error while performing a Software upgrade.	A. Turn Therapy System Off and back On. Reattempt upgrade. B. Replace the PC Board that the software is attempting to upgrade.
223	Error	Error while performing a Software upgrade.	A. Turn Therapy System Off and back On. Reattempt upgrade. B. Replace the PC Board that the software is attempting to upgrade.

5.1 THERAPY SYSTEM ERROR MESSAGES (CONTINUED)

ERROR MESSAGES REQUIRING TECHNICAL ASSISTANCE (200-299)			
Code Number	Type Message	Probable Cause	Possible Remedies
224	Error	Error while performing a Software upgrade.	A. Turn Therapy System Off and back On. Reattempt upgrade. B. Replace the PC Board that the software is attempting to upgrade.
225	Error	Error while performing a Software upgrade.	A. Turn Therapy System Off and back On. Reattempt upgrade. B. Replace the PC Board that the software is attempting to upgrade.
226	Error	Error while performing a Software upgrade.	A. Turn Therapy System Off and back On. Reattempt upgrade. B. Replace the PC Board that the software is attempting to upgrade.
227	Error	Error while performing a Software upgrade.	A. Turn Therapy System Off and back On. Reattempt upgrade. B. Replace the PC Board that the software is attempting to upgrade.
228	Error	Error while performing a Software upgrade.	A. Turn Therapy System Off and back On. Reattempt upgrade. B. Replace the PC Board that the software is attempting to upgrade.
229	Error	Error while performing a Software upgrade.	A. Turn Therapy System Off and back On. Reattempt upgrade. B. Replace the PC Board that the software is attempting to upgrade.
230	Error	Error while performing a Software upgrade.	A. Turn Therapy System Off and back On. Reattempt upgrade. B. Replace the PC Board that the software is attempting to upgrade.
231	Error	Error while performing a Software upgrade.	A. Turn Therapy System Off and back On. Reattempt upgrade. B. Replace the PC Board that the software is attempting to upgrade.
232	Error	Error while performing a Software upgrade.	A. Turn Therapy System Off and back On. Reattempt upgrade. B. Replace the PC Board that the software is attempting to upgrade.
233	Error	Error while performing a Software upgrade.	A. Turn Therapy System Off and back On. Reattempt upgrade. B. Replace the PC Board that the software is attempting to upgrade.
234	Error	Error while performing a Software upgrade.	A. Turn Therapy System Off and back On. Reattempt upgrade. B. Replace the PC Board that the software is attempting to upgrade.
235	Error	Error while performing a Software upgrade.	A. Turn Therapy System Off and back On. Reattempt upgrade. B. Replace the PC Board that the software is attempting to upgrade.
236	Error	Error while performing a Software upgrade.	A. Turn Therapy System Off and back On. Reattempt upgrade. B. Replace the PC Board that the software is attempting to upgrade.
237	Error	Error while performing a Software upgrade.	A. Turn Therapy System Off and back On. Reattempt upgrade. B. Replace the PC Board that the software is attempting to upgrade.
238	Error	Error while performing a Software upgrade.	A. Turn Therapy System Off and back On. Reattempt upgrade. B. Replace the PC Board that the software is attempting to upgrade.
239	Error	Error while performing a Software upgrade.	A. Turn Therapy System Off and back On. Reattempt upgrade. B. Replace the PC Board that the software is attempting to upgrade.
240	Error	Error while performing a Software upgrade.	A. Turn Therapy System Off and back On. Reattempt upgrade. B. Replace the PC Board that the software is attempting to upgrade.

NOTE:

Errors 219-231: after replacing the PC Board, and if the problem persists, send the Therapy System to the Factory for Service.

Errors 233-240: after replacing the PC Board, and if the problem persists, send the Therapy System to the Factory for Service.

If Errors 219-240 occur while attempting to upgrade Laser Software, send the Laser Module and Applicators to the Factory for Service.

5.1 THERAPY SYSTEM ERROR MESSAGES (CONTINUED)

CRITICAL ERRORS DEMANDING TECHNICAL SERVICE (300-399)			
Code Number	Type Message	Probable Cause	Possible Remedies
300	Critical Error	Stim Board not found on Power up.	<p>A. On Therapy System, make certain internal Ribbon Cable is seated on Stim PC Board and Control Board.</p> <p>B. On Channel 3/4 Electrotherapy Module, make certain the Therapy System to Module Ribbon Cable is seated in the Therapy System and on the Module.</p> <p>C. If problem persists, replace appropriate Stim PC Board.</p> <p>D. Replace Control Board.</p>
301	Critical Error	Stim Board failed Power up self test.	<p>A. On Therapy System, make certain internal Ribbon Cable is seated on Stim PC Board and Control Board.</p> <p>B. On Channel 3/4 Electrotherapy Module, make certain the Therapy System to Module Ribbon Cable is seated in the Therapy System and on the Module.</p> <p>C. If problem persists, replace appropriate Stim PC Board.</p> <p>D. Replace Control Board.</p>
302	Critical Error	Stim Board Reset occurred. But, neither the main uP nor channel uP reset bit was set.	<p>A. On Therapy System, make certain internal Ribbon Cable is seated on Stim PC Board and Control Board.</p> <p>B. On Channel 3/4 Electrotherapy Module, make certain the Therapy System to Module Ribbon Cable is seated in the Therapy System and on the Module.</p> <p>C. If problem persists, replace appropriate Stim PC Board.</p> <p>D. Replace Control Board.</p>
303	Critical Error	Main uP on Stim Board reset occurred.	<p>A. On Therapy System, make certain internal Ribbon Cable is seated on Stim PC Board and Control Board.</p> <p>B. On Channel 3/4 Electrotherapy Module, make certain the Therapy System to Module Ribbon Cable is seated in the Therapy System and on the Module.</p> <p>C. If problem persists, replace appropriate Stim PC Board.</p> <p>D. Replace Control Board.</p>
304	Critical Error	Channel A uP on Stim Board reset occurred.	<p>A. On Therapy System, make certain internal Ribbon Cable is seated on Stim PC Board and Control Board.</p> <p>B. On Channel 3/4 Electrotherapy Module, make certain the Therapy System to Module Ribbon Cable is seated in the Therapy System and on the Module.</p> <p>C. If problem persists, replace appropriate Stim PC Board.</p> <p>D. Replace Control Board.</p>
305	Critical Error	Channel B uP on Stim Board reset occurred.	<p>A. On Therapy System, make certain internal Ribbon Cable is seated on Stim PC Board and Control Board.</p> <p>B. On Channel 3/4 Electrotherapy Module, make certain the Therapy System to Module Ribbon Cable is seated in the Therapy System and on the Module.</p> <p>C. If problem persists, replace appropriate Stim PC Board.</p> <p>D. Replace Control Board.</p>
306	Critical Error	Error writing to Stim Board.	<p>A. On Therapy System, make certain internal Ribbon Cable is seated on Stim PC Board and Control Board.</p> <p>B. On Channel 3/4 Electrotherapy Module, make certain the Therapy System to Module Ribbon Cable is seated in the Therapy System and on the Module.</p> <p>C. If problem persists, replace appropriate Stim PC Board.</p> <p>D. Replace Control Board.</p>
307	Critical Error	Error writing from Stim Board.	<p>A. On Therapy System, make certain internal Ribbon Cable is seated on Stim PC Board and Control Board.</p> <p>B. On Channel 3/4 Electrotherapy Module, make certain the Therapy System to Module Ribbon Cable is seated in the Therapy System and on the Module.</p> <p>C. If problem persists, replace appropriate Stim PC Board.</p> <p>D. Replace Control Board.</p>

5.1 THERAPY SYSTEM ERROR MESSAGES (CONTINUED)

CRITICAL ERRORS DEMANDING TECHNICAL SERVICE (300-399)			
Code Number	Type Message	Probable Cause	Possible Remedies
308	Critical Error	Error reading from Stim Board.	<p>A. On Therapy System, make certain internal Ribbon Cable is seated on Stim PC Board and Control Board.</p> <p>B. On Channel 3/4 Electrotherapy Module, make certain the Therapy System to Module Ribbon Cable is seated in the Therapy System and on the Module.</p> <p>C. If problem persists, replace appropriate Stim PC Board.</p> <p>D. Replace Control Board.</p>
309	Critical Error	Error reading from Stim Board.	<p>A. On Therapy System, make certain internal Ribbon Cable is seated on Stim PC Board and Control Board.</p> <p>B. On Channel 3/4 Electrotherapy Module, make certain the Therapy System to Module Ribbon Cable is seated in the Therapy System and on the Module.</p> <p>C. If problem persists, replace appropriate Stim PC Board.</p> <p>D. Replace Control Board.</p>
310	Critical Error	Ultrasound Board has reported an error.	<p>A. Make certain Ultrasound PC Board is completely seated on internal Header and Ribbon Cable is seated on Stim PC Board and Control Board.</p> <p>B. If problem persists, replace Ultrasound PC Board.</p> <p>C. Replace Control Board .</p>
311	Critical Error	Ultrasound Board has reset.	<p>A. Make certain Ultrasound PC Board is completely seated on internal Header and Ribbon Cable is seated on Stim PC Board and Control Board.</p> <p>B. If problem persists, replace Ultrasound PC Board.</p> <p>C. Replace Control Board .</p>
312	Critical Error	Error writing to Ultrasound Board.	<p>A. Make certain Ultrasound PC Board is completely seated on internal Header and Ribbon Cable is seated on Stim PC Board and Control Board.</p> <p>B. If problem persists, replace Ultrasound PC Board.</p> <p>C. Replace Control Board .</p>
313	Critical Error	Error reading from Ultrasound Board.	<p>A. Make certain Ultrasound PC Board is completely seated on internal Header and Ribbon Cable is seated on Stim PC Board and Control Board.</p> <p>B. If problem persists, replace Ultrasound PC Board.</p> <p>C. Replace Control Board .</p>
314	Critical Error	Error reading from Ultrasound Board.	<p>A. Make certain Ultrasound PC Board is completely seated on internal Header and Ribbon Cable is seated on Stim PC Board and Control Board.</p> <p>B. If problem persists, replace Ultrasound PC Board.</p> <p>C. Replace Control Board .</p>
315	Critical Error	Error reading from Ultrasound Board.	<p>A. Make certain Ultrasound PC Board is completely seated on internal Header and Ribbon Cable is seated on Stim PC Board and Control Board.</p> <p>B. If problem persists, replace Ultrasound PC Board.</p> <p>C. Replace Control Board .</p>
316	Critical Error	Error writing to Module Board.	<p>A. Make certain the Therapy System to Module Ribbon Cable is seated in the Therapy System and on the Module.</p> <p>B. If problem persists, replace appropriate Stim PC Board.</p> <p>C. Replace Control Board.</p>
317	Critical Error	Error reading from Module Board.	<p>A. Make certain the Therapy System to Module Ribbon Cable is seated in the Therapy System and on the Module.</p> <p>B. If problem persists, replace appropriate Stim PC Board.</p> <p>C. Replace Control Board.</p>
318	Critical Error	Error reading from Module Board.	<p>A. Make certain the Therapy System to Module Ribbon Cable is seated in the Therapy System and on the Module.</p> <p>B. If problem persists, replace appropriate Stim PC Board.</p> <p>C. Replace Control Board.</p>
319	Critical Error	Error writing to Laser Board.	<p>A. Replace Control Board.</p> <p>B. Send Laser Module to factory for Service.</p>

5.1 THERAPY SYSTEM ERROR MESSAGES (CONTINUED)

B. The information provided below is intended to aid in additional troubleshooting of the Vectra Genesis, Intellect Legend XT or Intellect Vet Therapy Systems.

NOTE:

No Field Service is applicable to the Laser Module or Laser Applicators. All Laser Applicators suspected to require service or calibration must be sent to the factory.

Problem	Probable Cause	Possible Remedies
Channel 3/4 Module, Laser, or NiMH Battery Module not recognized.	<ol style="list-style-type: none"> 1. Bad connection between System and Module. 2. Bad Module. 3. Bad Control Board. 	<ol style="list-style-type: none"> A. Make Certain Ribbon Cable is installed correctly and seated completely. B. If Battery or Laser, replace with known good module. If Channel 3/4 Electrotherapy Module, make necessary repairs. C. Replace Control Board.
sEMG Module not recognized.	<ol style="list-style-type: none"> 1. Bad contact between Stim Board and sEMG Module. 2. Bad sEMG Module. 3. Bad Stim Board. 4. Bad Control Board. 	<ol style="list-style-type: none"> A. Remove sEMG Module and make certain the stim board is seated completely in the System housing. Check 1/4 Turn Screw for proper installation. B. Replace with known good sEMG Module. C. Replace Stim Board. D. Replace Control Board.
Operator Remote Control doesn't work according to User Manual instructions.	<ol style="list-style-type: none"> 1. Early Revision of Stim Board and Connector Board. 2. Bad Operator Remote Control. 3. Bad Connector PC Board. 4. Bad Stim Board. 5. Bad Control Board. 	<ol style="list-style-type: none"> A. Follow "Amendment to Operation" document shipped with Operator Remote. B. Therapy System- Replace Stim Board with 27057 Rev. E or above and Connector Board with 27059 Rev E or above. Channel 3/4 Electrotherapy Module- Replace Stim Board with 27057 Rev. E or above and Connector Board with 27060 Rev F or above. C. Replace with known good Operator Remote Control. D. Replace Control Board.
Laser Module not functioning after proper intallation has been performed.	<ol style="list-style-type: none"> 1. Therapy System Software not updated. 	<ol style="list-style-type: none"> 1. Update Therapy System Software to Version 2.0 or greater.

5.2 THERAPY SYSTEM TESTING

A. General

1. The following information is intended to aid in troubleshooting the major components of the Vectra Genisys, Intelect Legend XT and Intelect Vet Therapy Systems to “Board Level” only. These tests are FACTORY standard testing procedures and methods used at the factory before shipment of any Vectra Genisys, Intelect Legend XT, or Intelect Vet Therapy System.
2. Due to the complex nature of the technology utilized by Chattanooga Group, the recommended troubleshooting techniques are to determine “Bad Board” and board replacement only. No board component level troubleshooting is recommended nor will information or parts be supplied by Chattanooga Group. Any board component level troubleshooting performed will be at sole risk and liability of the Service Technician performing such troubleshooting techniques.
3. Once a particular PC Board has been determined as bad, refer to the appropriate Removal and Replacement Section of this Manual for proper replacement.

B. Special Tools, Fixtures, & Materials Required

1. Certain tests require the use of special tools and fixtures. These will be listed at the particular test where they are required. Testing with any other special tool or fixture other than those stated could give erroneous readings or test results. Always perform the tests exactly as stated to ensure accurate results.
2. Any special tools or fixtures required can be obtained through Chattanooga Group Service Department.
3. Scope and other standard test equipment settings will be listed for each test performed to aid in performing the test to FACTORY standards and ensure proper readings.
4. The troubleshooting and repair of the Vectra Genisys, Intelect Legend XT or Intelect Vet Therapy Systems, Modules, and Accessories should be performed only by authorized technicians trained and certified by Chattanooga Group.

C. Equipment Required

1. Oscilloscope and Probes
2. ESTI-2 Load Test Fixture
3. Digital Multimeter
4. Microcurrent Probe (Accessory)
5. Operator Remote Control (Optional Accessory)

6. Ultrasound Applicators (Accessories)

7. Dielectric Withstand (Hi-Pot) and ground resistance tester

NOTE:

Adjust Dielectric Withstand tester to indicate fault with 120 k Ohm Load across the output when at specified test voltage.

8. Milliohm Meter
9. Ohmic Instruments UPM DT 10 or DT 100 Ultrasound Power Meter
10. Audio Signal Generator, B-K Precision, Model 3001
11. 14 cm diameter (5.50”) Optical Cast IR Longpass Filter (For Cluster Laser Applicators)
12. UV and IR Laser Detection Cards (For Laser Applicators)
13. Dissolved Oxygen Test Kit. Used to test oxygen level of degassed water
14. Degassed Water (<5 ppm) for Ultrasound Power Meter

D. Recipe(s) for Degassed Water

1. Boil Distilled Water for 30 minutes. Place water in a non-porous container and immediately cover with cellophane. Allow to cool to room temperature of approximately 70 °F (21 °C). May be refrigerated to aid cooling time.
2. Bring Distilled Water to a boil. Place the container under vacuum for 5 to 10 minutes.

NOTE:

Two liter soft drink bottles are ideal storage and transport containers for degassed water as they are designed to keep oxygen out. Do not allow aeration of degassed water during transport or filling of the power meter.

Do not use Tap water or Distilled water in the Ultrasound Power Meter. Use only Degassed Water in order to obtain correct test results. The chart below illustrates the oxygen content of Degassed, Tap and Distilled Water.

WATER TYPE	ppm of Oxygen
Degassed per recipe 1 or 2	Less than 5 ppm
Tap Water	Up to 35 ppm
Distilled Water	Up to 20 ppm

E. Full Functional Tests

Perform the tests found in this section to verify Full Functionality of new Therapy Systems and related Modules and accessories.

5.3 VISUAL INSPECTION

Visually inspect the Vectra Genisys, Intelect Legend XT and Intelect Vet Therapy Systems. A visual inspection can, to an experienced technician, indicate possible abuse of the unit and internal problems.

5.4 LEAKAGE TESTS

Conduct all necessary leakage tests as required per “Chapter 7 Electrical Equipment” of the 1999, or later, edition of the NFPA (National Fire Protection Association) “Health Care Facility” standards. **See Figure 5.1.**

5.5 UNIT STARTUP AND FAN TESTING

A. Test

1. Place System face up on work surface.
2. Connect power cord to unit and plug into an approved power receptacle.
3. Turn system on. Press the Electrotherapy Button. Press the Interferential Button.
4. Place hand at the back of system, at Mains Power Switch, to verify fan is blowing out.
See Figure 5.2.

B. Test Results

1. Unit will not Start= Unit Failed Test
 - a) Bad Fuse.
 - b) Possible bad Main Power Switch.
 - c) Possible bad Power Supply.
 - d) Possible bad power outlet or Power Cord.
2. Home Screen does not display= Unit Failed Test.
 - a) Possible bad display.
 - b) Possible bad Control Board.
 - c) Possible bad Power Supply.

Visually check power LED. LED Should illuminate Blue. Turn system off with power switch. Power LED should illuminate Green. If Power LED illuminates Blue with system On and Green with system Off, the Power Supply is good. Replace Control Board.
3. Fan not blowing outward= Unit Failed Test
 - a) Fan Blowing Inward.

Fan wired wrong. Rewire or replace fan.
 - b) Fan not blowing.
 - 1) Possible bad Fan.
 - 2) Possible bad Power Supply.
 - 3) Possible bad Control Board.

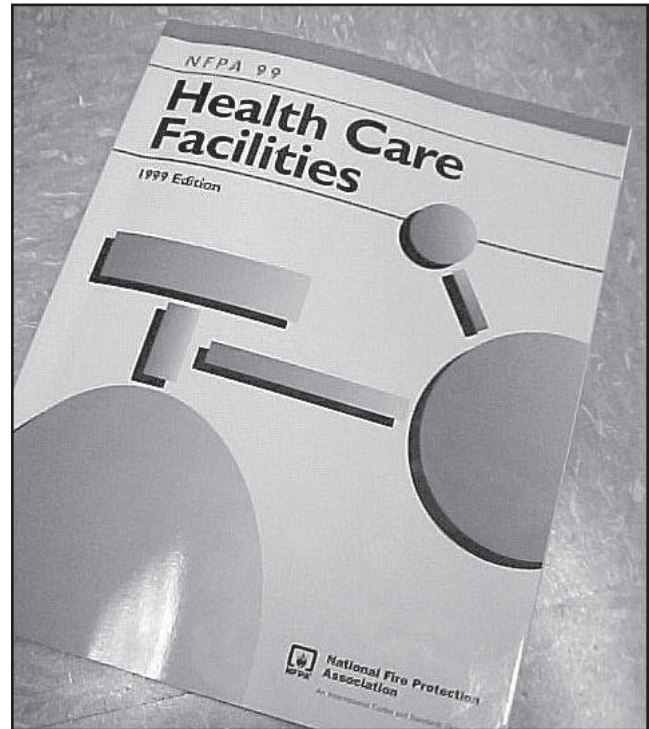

FIGURE 5.1



FIGURE 5.2

5.6 STIMULATOR TEST SYSTEM SETUP

The following tests for Stimulator Outputs will be performed on Channels 1 and 2. The performance of these same tests will apply to the Channel 3 and 4 Electrotherapy Module for four channel therapy systems.

A. Equipment Required

1. ESTI-2 Load Test Fixture
2. Calibrated Oscilloscope and Probes

B. System Set Up

1. Install known good Lead Wires to Channels 1 and 2 on the system or Channels 3 and 4 on the Channel 3/4 Electrotherapy Module. **See Figure 5.3.**
2. Connect Lead Wires from the system to the ESTI-2 Load Test Fixture- Channel 1 or 3 to Channel 1 IN and Channel 2 or 4 to Channel 2 IN. **See Figure 5.4.**
3. Connect Scope Probes to the Channel 1 To SCOPE and Channel 2 To SCOPE Tabs on the ESTI 2 Load Test Fixture respectively. **See Figure 5.4.**
4. Place ESTI-2 Load Switch in the 1 K position. **See Figure 5.4.**
5. Install power cord into system and plug into proper power supply. Turn system On.

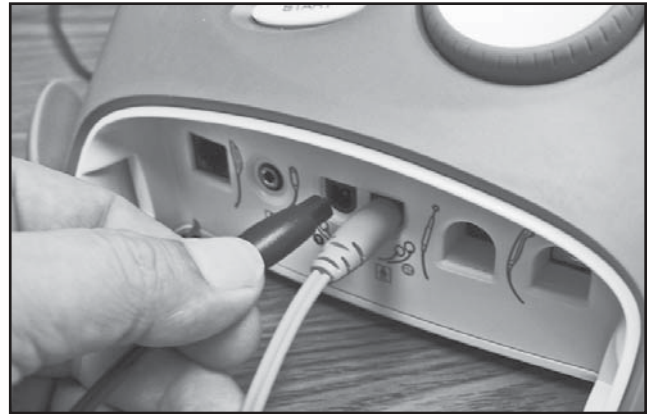

FIGURE 5.3

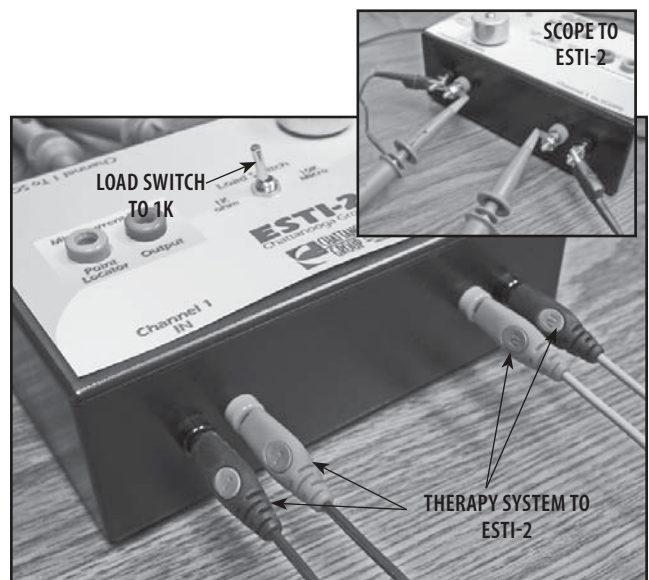

FIGURE 5.4

5.7 VMS™ MODE TEST

A. VMS™ Mode Test Procedures

1. Set Scope; Time- 100 μ S, Channel- 50 V, and Trigger- DC
2. Press Electrotherapy Button.
3. Press VMS Button and then press Edit Button.
4. Press "Channel Mode" until "Co-Contracted" is displayed just beneath "Channel Mode".
5. Press Cycle Time Button until "Continuous" is displayed.
6. Press Phase Duration and press the Up Arrow until 300 is displayed just below "Phase Duration".
7. Press the Accept and Return Arrow.
8. Turn Therapy Intensity Control clockwise until 200 is displayed.
9. Press "Start".
10. Compare waveform on scope to **Figure 5.5**.
11. Press Stop Button. Then press Home Button.
12. Press Select Channel Button until Channel 2 is selected. **Repeat steps 2 through 11.**

B. VMS™ Mode Test Results

1. Waveform is the same between scope and **Figure 5.5**.
Unit passed test.
2. No waveform or considerably different waveform.
Unit failed test. Replace appropriate Stim PC Board.

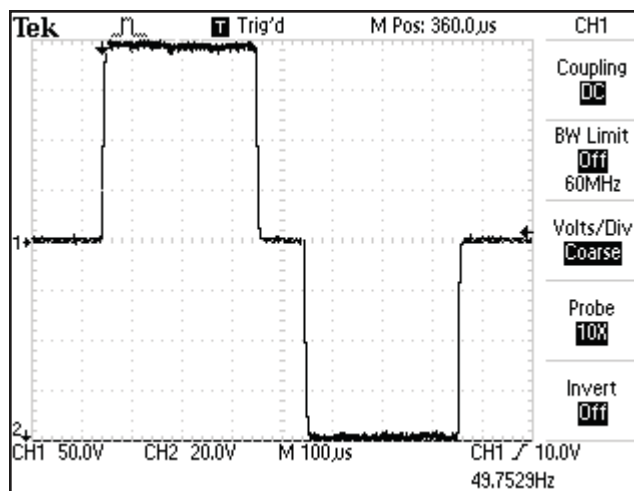

FIGURE 5.5

5.8 INTERFERENTIAL MODE TEST

It is assumed that the unit is ready for tests as described in **5.6 parts A and B**. If not, Set up Unit per **5.6 parts A and B** prior to performing tests.

A. Interferential Mode Test Procedures

1. Set Scope; Time- 100 μ S, Channel- 20 V, and Trigger- DC.
2. Press Electrotherapy Button.
3. Press IFC Traditional (4p) Button.
4. Rotate Therapy Intensity Control clockwise until 50 is displayed.
5. Press Start Button.
6. Compare waveform form on scope to **Figure 5.6**.
7. Press "Pause".
8. Verify that the amplitude displayed below timer and beside Channel 1 and 2 icons drops to zero (0). Verify that "Paused" is displayed beside the "Channel 1" and "Channel 2" icons.
9. Press Stop Button.
10. Press the Home Button. Move Lead wires to Channels 3 and 4 on 4 Channel Systems and repeat **steps 2 through 9**.

B. Interferential Mode Test Results

1. Waveform is the same between scope and **Figure 5.6**, amplitude dropped to zero when paused and "Paused" displayed beside channel icons.
Unit passed test.
2. No waveform or considerably different waveform.
Unit failed test. Replace appropriate Stim Board.
3. Amplitude failed to "zero" when paused.
Unit failed test. Replace appropriate Stim Board.
4. "Paused" did not display when unit paused.
Unit failed test. Replace appropriate Stim Board.

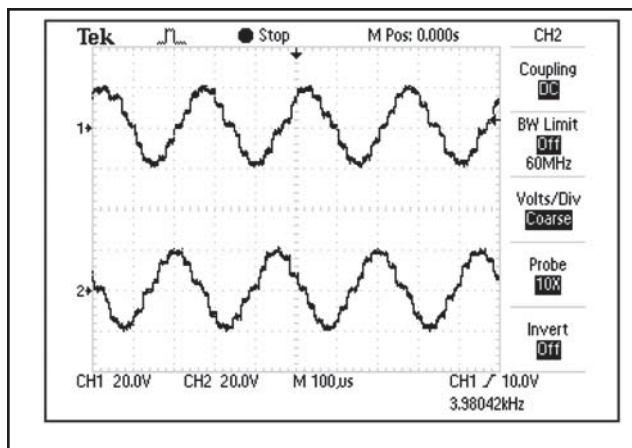

FIGURE 5.6

5.9 PREMODULATED MODE TEST

Set up System per **5.6 parts A and B** prior to performing test.

A. Premodulated Mode Test Procedures

1. Set Scope; Time- 2.50 mS, Channel- 20 V, and Trigger- DC.
2. Press Electrotherapy Button.
3. Press IFC Premodulated (2p) Button.
4. Rotate Intensity Control clockwise until 50 is displayed.
5. Press "Start".
6. Compare waveform form on scope to **Figure 5.7**.
7. Press Stop. Then press Home Button and move scope probes to Channel 2 and repeat **steps 2 through 6**. Repeat test on channels 3 and 4 on 4 Channel Systems.

B. Premodulated Mode Test Results

1. Waveform is the same between scope and **Figure 5.7**.
Unit passed test.
2. No waveform or considerably different waveform.
Unit failed test. Replace appropriate Stim Board.

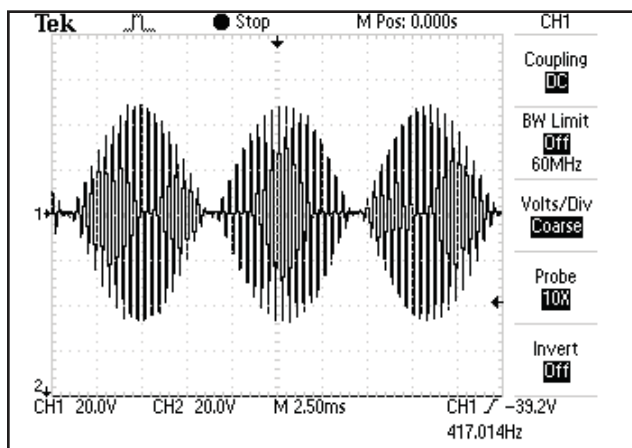

FIGURE 5.7

5.10 RUSSIAN MODE TEST

Set up System per **5.6 parts A and B** prior to performing test.

A. Russian Mode Test Procedures

1. Set Scope; Time- 5 mS, Channel- 50 V, and Trigger- DC.

NOTE:

A test of the Optional Patient Interrupt Switch is provided within the Russian Mode Test. If you do not have the Optional Patient Interrupt Switch, skip **steps 2, and 11**.

2. Install Patient Interrupt Switch. **See Figure 5.8.**
3. Press Electrotherapy Button.
4. Press Russian Button. Press Edit Button.
5. Press Channel Mode until Co-Contract is displayed.
6. Press the Cycle Time Button until Continuous is displayed.
7. Rotate Therapy Intensity Control clockwise until 100 is displayed.
8. Press "Start".
9. Compare waveform on scope to **Figure 5.9.**
10. Verify that both Channels reach 100.
11. Press Patient Interrupt Switch. Verify treatment stops and "Patient Switch for Ch 1 and 2 was pressed. Press any button to continue..." message appears. **See Figure 5.9A.** Press any button.
12. Press Stop Button. Press Home Button and move scope probes to Channel 3 and 4 on 4 Channel Systems. Repeat **steps 2 through 11.**

B. Russian Mode Test Results

1. Waveform is the same between scope and Figure 5.9, amplitude reached 100 and patient switch message displayed when switch pressed. **See Figure 5.9A.** Unit passed test.
2. No waveform or considerably different waveform. Unit failed test. Replace appropriate Stim Board.
3. Amplitude failed to reach 100 on both Channels. Unit failed test. Replace appropriate Stim Board.
4. Patient Switch message did not display when patient switch pressed. (Optional Patient Switch present) Unit failed test.
 - a) Try a known good Patient Switch and repeat test.
 - b) Replace appropriate Stim Board.



FIGURE 5.8

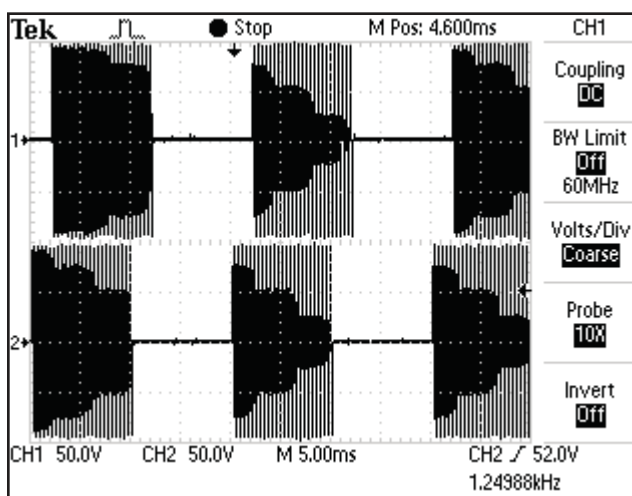

FIGURE 5.9



FIGURE 5.9A

5.11 MICROCURRENT MODE TEST

NOTE:

This test does not apply to the Intelect Vet Therapy System.

Set up System per **5.6 parts A and B** prior to performing test.

Place ESTI-2 Load Switch in the 10 K Micro position only for the Microcurrent Mode Tests. **See Figure 5.10.**

A. Microcurrent Mode Test Procedures

1. Set Scope; Time- 250 μ S, Channel- 5.0 V, and Trigger- DC.
2. Press Electrotherapy Button.
3. Press Microcurrent Button and press Edit Button.
4. Press Frequency Button.
5. Press the Up Arrow Button until 1000.0 Hz is displayed.
6. Press the Accept and Return Arrow.

NOTE:

1000.0 Hz should be displayed within the Frequency icon. If not, repeat **steps 4 through 6.**

7. Press "Polarity" until "Alternating" appears within the Polarity icon.

NOTE:

The Frequency value will continue to ramp and rotate due to Alternating Polarity being selected. This is normal.

8. Rotate Therapy Intensity Control until 1000 is displayed.
9. Press "Start".

10. Compare waveform on scope to **Figure 5.11** and **Figure 5.11A.**

NOTE:

The output will alternate between positive and negative on the scope.

11. Press Stop Button and then press Home Button.
12. Select the next channel to be tested by pressing the Select Channel Button until the desired channel is selected. Repeat **steps 2 through 11** for each channel.

B. MicroCurrent Mode Test Results

1. Waveform is the same between scope and **Figure 5.11** and **Figure 5.11A.**
Unit passed test.
2. No waveform or considerably different waveform.
Unit failed test. Replace appropriate Stim Board.

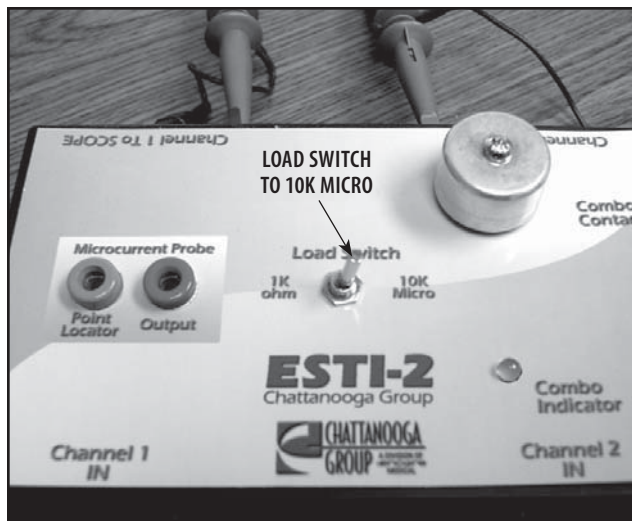

FIGURE 5.10

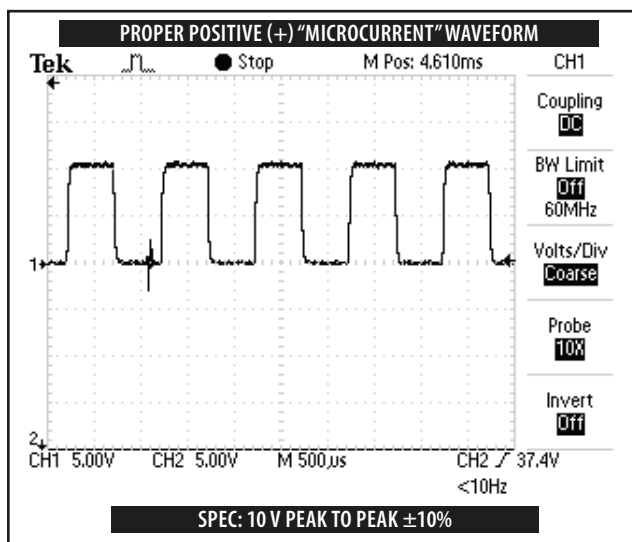

FIGURE 5.11

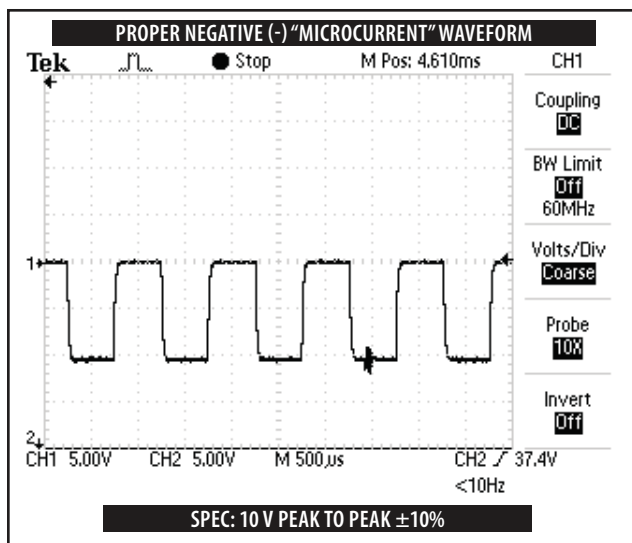

FIGURE 5.11A

5.12 HIGH VOLTAGE PULSED CURRENT (HVPC) MODE TEST

Set up Unit per **5.6 parts A and B** prior to performing tests.

A. High Voltage Pulsed Current (HVPC) Mode Test Procedures

1. Set Scope; Time- 25 μ S, Channel- 50 V, and Trigger- DC.
2. Press Electrotherapy Button.
3. Press High Volt Button.
4. Rotate Therapy Intensity Control clockwise until 250 Volts is displayed.
5. Press Start Button.
6. Compare waveform on scope to **Figure 5.12**.
7. Press Edit Button.
8. Press Polarity Button until Positive is displayed in Polarity icon.
9. Compare waveform form on scope to **Figure 5.13**.
10. Press Display Button until Peak Current is displayed in the Display icon.
11. The numbers displayed for amplitude must not exceed 1.5 Amps. **See Figure 5.14**.
12. Press "Stop".

B. High Voltage Pulsed Current (HVPC) Mode Test Results

1. Waveforms on scope the same as **Figures 5.12 and 5.13** and Amps do not exceed 1.5.
Unit passed test.
2. No waveform or considerably different waveforms.
Unit failed test. Replace appropriate Stim Board.
3. Amps exceed 1.5.
Unit failed test. Replace appropriate Stim Board.

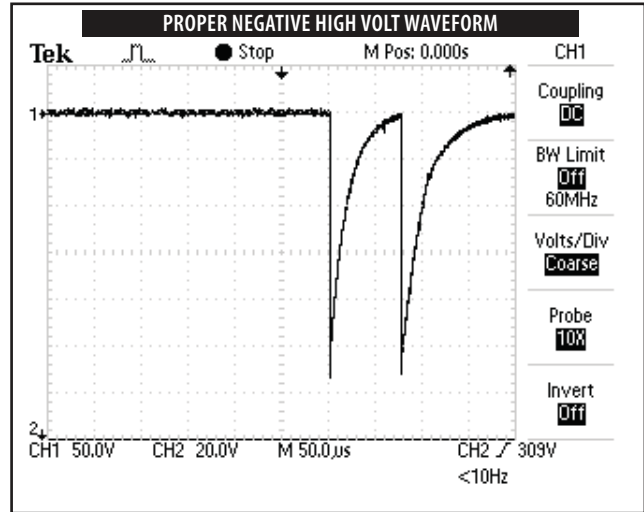

FIGURE 5.12

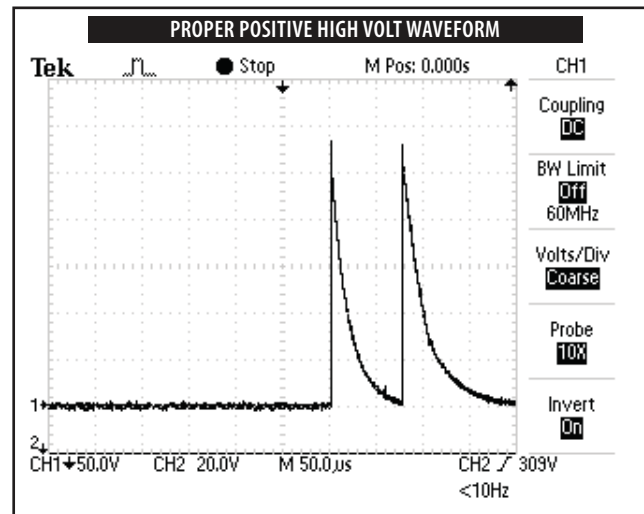

FIGURE 5.13

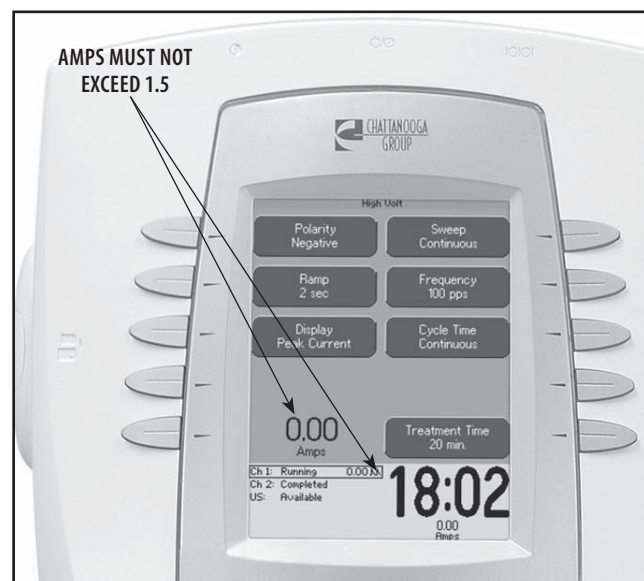

FIGURE 5.14

5.13 MICROCURRENT PROBE MODE TEST

NOTE:

This test does not apply to the Intellect Vet Therapy System.

Set up Unit per **5.6 parts A and B** prior to performing tests.

Black Lead Wire for Channel 1 and Channel 3, and Microcurrent Probe with Probe Tips are required for this test.

NOTE:

This test to be performed on Channel 1 and 3 only.

A. Microcurrent Probe Mode Test Procedures

1. Install the Black Lead Wire into Channel 1 connector on System. **See Figures 5.15 and 5.16.**
2. Install a Probe Tip into Microcurrent Probe and plug Probe into Microcurrent connector on the Therapy System. **See Figure 5.15.**
3. Press Electrotherapy Button.
4. Press Microcurrent Button. Press Edit Button.
5. Press Method Button until Probe is displayed within the Method icon. An audible beep will be heard, this is the Search Mode Beep. A Contact Quality Scale will also appear on the screen.
6. Touch the probe to the metal tip of the Black (-) Leadwire. **See Figure 5.16.**
7. The beep (search mode) should increase in speed and the Contact Quality scale should display a full vertical Green Bar on Color Systems, Gray on Monochrome. **See Figure 5.17.**
8. Press the blue button on the probe. The Search Mode Beep should stop and the treatment timer should begin countdown. Once the treatment timer is at zero (0), three high pitch beeps will be heard. The Search Mode Beep will restart simultaneously [with probe away from the metal tip of the Black (-) Leadwire].
9. Repeat **steps 6 and 7** to verify Search Mode Beep speed increases and Contact Quality icon gives a full vertical Green or Gray bar.
10. Press Stop Button. This should terminate the Search Mode Beep, stop the treatment and the Home Screen should be displayed.



FIGURE 5.15

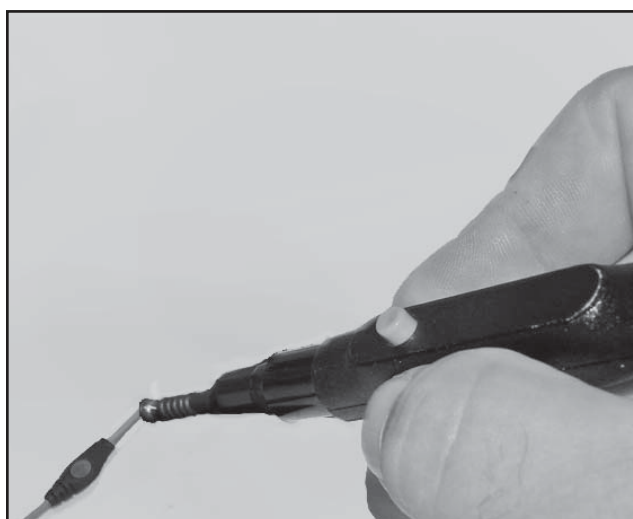

FIGURE 5.16

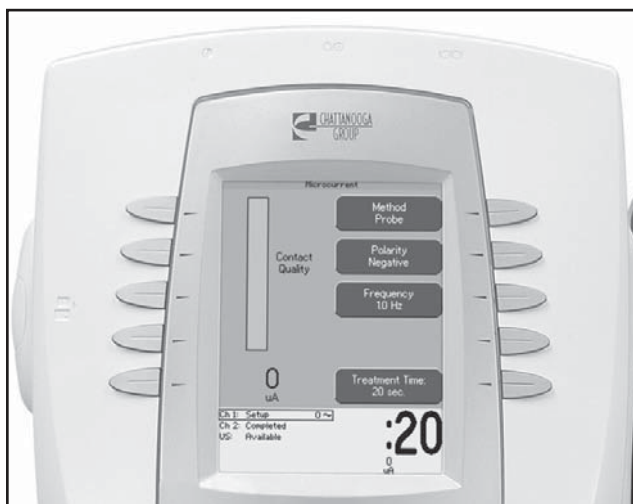

FIGURE 5.17

5.13 MICROCURRENT PROBE MODE TEST (CONTINUED)

B. MicroCurrent Probe Mode Test Results

1. Unit performs as described in **steps 5-7 and 10.**
Unit passed test.
2. No Search Mode Beep. Unit failed test. Try a known good Microcurrent Probe and repeat test. If still no beep. Replace appropriate Stim Board.
3. Good Search Mode beep but no beep speed increase when probe touched to metal tip of the Black (-) Leadwire.
Unit failed test.
Replace probe, and lead wire with known good probe, and lead wire. Repeat test and use process of elimination to determine if probe, or lead wire is the problem. Same results after test is repeated, replace appropriate Stim Board.
4. Tones OK but no Green or Gray vertical bar in Contact Quality Scale. Unit failed test.
Replace appropriate Stim Board. If problem persists, replace Control Board.

5.14 ULTRASOUND TESTS

A. Equipment Required

1. Degassed Water. Refer to **page 37** for Degassed Water Recipes.
2. Ohmic Instruments UPM DT 10 or DT 100 Ultrasound Power Meter.
3. Dissolved Oxygen Test Kit. Used to test oxygen level of degassed water.
4. Ultrasound Applicator.

5.15 ULTRASOUND APPLICATOR IDENTIFICATION TEST

NOTE:

Use any Vectra Genisys, Intellect Legend XT or Intellect Vet Ultrasound Applicator for this test.

A. Ultrasound Applicator Identification Test Procedures

1. Without Applicator installed, turn unit on.
2. Look at the “Ultrasound” channel icon at the lower Left Hand corner of screen. It should read “No Appl.” **See Figure 5.18.**
3. Plug the Ultrasound Applicator into Applicator connector. **See Figure 5.19.** Watch Applicator LED while connecting to System. The LED should flash Green five times.
4. Look at the “Ultrasound” channel icon. It should read Available. **See Figure 5.19.**
5. Press the Ultrasound Button. Press the Edit Button.
6. Press the Head Warming Button until On is displayed.
7. Press the Back Button. Turn System Off and Back On with Main Power Switch. After System boots, view the Ultrasound icon, Head Warming should be visible. **See Figure 5.20.**

B. Ultrasound Applicator Identification Test Results

1. Unit operates as described in **steps 2, 4, and 7.** Unit passed test.
2. “Appl. Not Cal.” displays in Ultrasound channel icon.
 - a) Applicator not calibrated or needs re-calibration.
 - b) Possible bad Applicator. Re-test with known good Applicator.
3. “No Appl.” displayed after ten seconds of Applicator being connected to System.
 - a) Possible bad applicator. Re-test with known good Applicator.
 - b) Possible bad internal connection at Ultrasound Board.
 - c) Possible bad Ultrasound Board.
 - d) Possible bad Control Board.

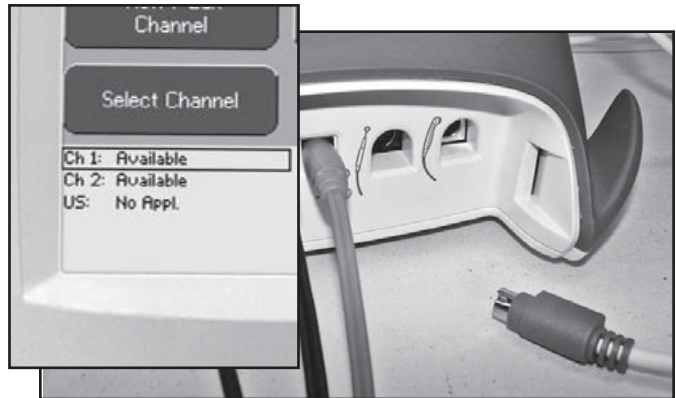

FIGURE 5.18

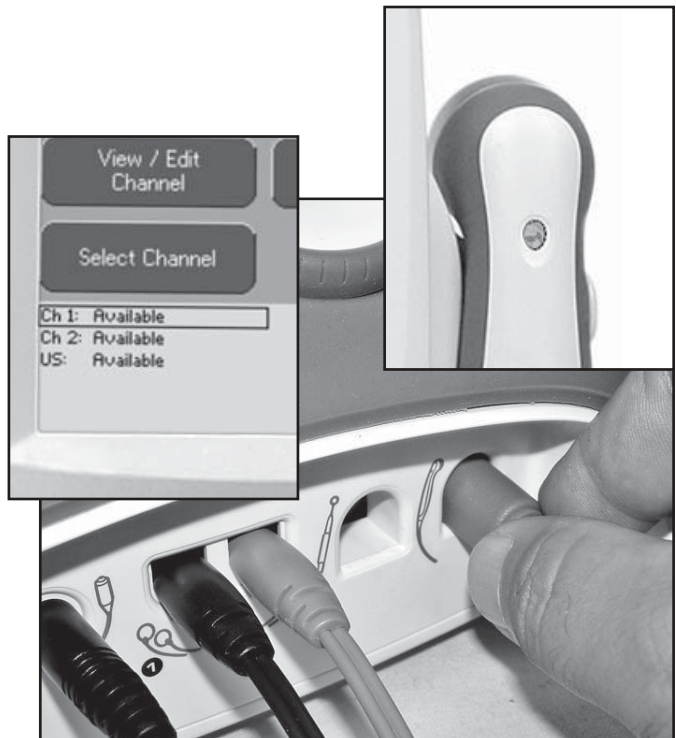

FIGURE 5.19

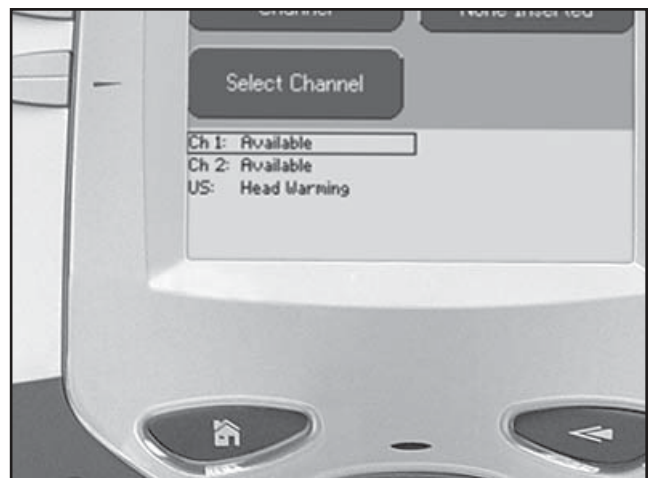

FIGURE 5.20

5.16 ULTRASOUND APPLICATOR OUTPUT TEST

Perform this test using all available Vectra Genisys, Intellect Legend XT or Intellect Vet Applicators for the System being tested.

A. Ultrasound Applicator Output Test Procedures

1. Set up Ohmic Instruments UPM DT 10 or DT 100 Ultrasound Power Meter per Operator's Instructions and fill test reservoir with Degassed Water.
2. Place an Applicator into the Power Meter retainer. Make certain the Sound Head is completely submerged in the degassed water and centered directly over the Stainless Steel Cone. **See Figure 5.21.**
3. "Zero" meter.
4. Press Ultrasound Button. Press Edit Button.
5. Press Duty Cycle Button until 100% is displayed within the Duty Cycle icon.
6. Press Display Button until "Watts" appears within the Display icon.
7. Press "Start".
8. Rotate Therapy Intensity Control clockwise until the appropriate "Watts" is displayed per **Figure 5.22.**
9. Compare Power Meter readings to Figure 5.22 to all settings for the respective Applicator being tested as shown in **Figure 5.22.**
10. Press Frequency Button until 3.3 MHz is displayed within the Frequency icon. Repeat test and compare readings to **Figure 5.22.**

NOTE:

The Applicator LED should constantly illuminate green during the Applicator Output tests.

B. Ultrasound Applicator Output Test Results

1. Output ranges fall within the specified ranges as listed in **Figure 5.22.** Unit passed test.
2. Readings fall outside specified ranges of **Figure 5.22.**
 - a) Possible bad Degassed Water in Power Meter.
 - b) Possible use of Power Meter other than Ohmic Instruments UPM DT 10 or DT 100 Ultrasound Power Meter.
 - c) Possible bad or out of calibration Applicator.
 - d) Possible bad internal connection at Ultrasound Board.
 - e) Check Ultrasound Board internal connections.
 - f) Replace Ultrasound Board.
 - g) Replace Control Board

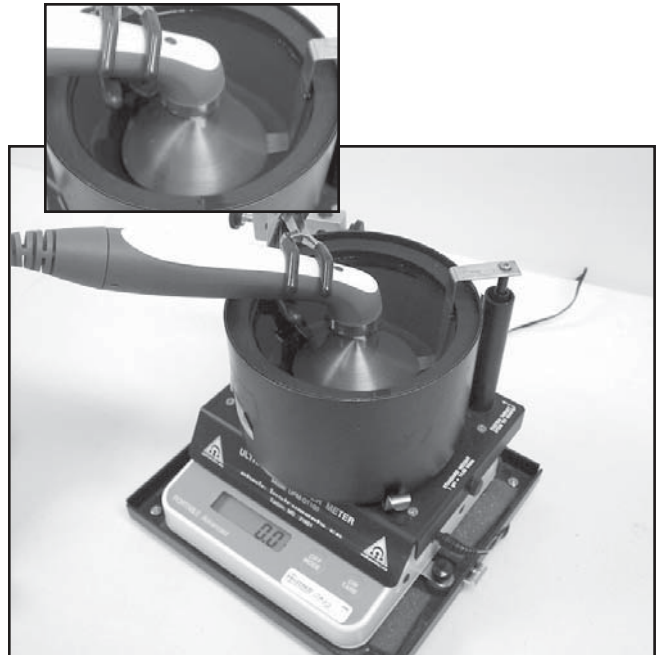

FIGURE 5.21

WARNING

USE ONLY DEGASSED WATER IN POWER METER FOR TESTING ULTRASOUND APPLICATORS. USE OF OTHER TYPES OF WATER WILL CAUSE FALSE TEST RESULTS. **SEE PAGE 37** FOR DEGASSED WATER RECIPES.

DO NOT AERATE WATER WHEN FILLING POWER METER

APPLICATOR OUTPUT SPECIFICATIONS		
APPLICATOR SIZE	POWER SETTINGS	OUTPUT RANGE
1 cm ²	1	0.8 - 1.2
	2	1.6 - 2.4
2 cm ²	1	0.8 - 1.2
	2	1.6 - 2.4
	4	3.2 - 4.8
5 cm ²	1	0.8 - 1.2
	2	1.6 - 2.4
	5	4.0 - 6.0
	10	8.0 - 12.0
10 cm ²	1	0.8 - 1.2
	5	4.0 - 6.0
	10	8.0 - 12.0
	15*	12.0 - 18.0
	20*	16.0 - 24.0

* 1 MHz Only

FIGURE 5.22

5.17 ULTRASOUND DUTY CYCLE TEST

This test is performed using only the 5 cm² Vectra Genisys, Intelect Legend XT or Intelect Vet Applicator.

A. Ultrasound Duty Cycle Test Procedures

1. Set up Ohmic Instruments UPM DT 10 or DT 100 Ultrasound Power Meter per Operator's Instructions and fill test reservoir with Degassed Water.
2. Place an Applicator into the Power Meter retainer. Make certain the Sound Head is completely submerged in the degassed water and centered directly over the Stainless Steel Cone. **See Figure 5.23.**
3. "Zero" meter.
4. Press Ultrasound Button. Press Edit Button.
5. Press Duty Cycle Button until 100% is displayed within the Duty Cycle icon.
6. Press Display Button until "Watts" appears within the Display icon.
7. Press "Start".
8. Rotate Therapy Intensity Control clockwise until "Watts" is displayed. **See Figure 5.24.**
9. Compare Power Meter readings to **Figure 5.24** to all settings for the respective Applicator being tested as shown in **Figure 5.24.**
10. Press Frequency Button until 3.3 MHz is displayed within the Frequency icon. Repeat test and compare readings to **Figure 5.24.**

B. Ultrasound Duty Cycle Test Results

1. Duty Cycles fall within the specified ranges as listed in **Figure 5.24.** Unit passed test.
2. Readings fall outside specified ranges of **Figure 5.24.**
 - a) Possible bad degassed water in Power Meter.
 - b) Possible use of Power Meter other than Ohmic Instruments UPM DT 10 or DT 100 Ultrasound Power Meter.
 - c) Possible bad or out of calibration Applicator. Re-test with known good Ultrasound Applicator.
 - d) Possible bad internal connection at Ultrasound Board.
 - e) Check Ultrasound Board internal connections.
 - f) Replace Ultrasound Board.
 - g) Replace Control Board.

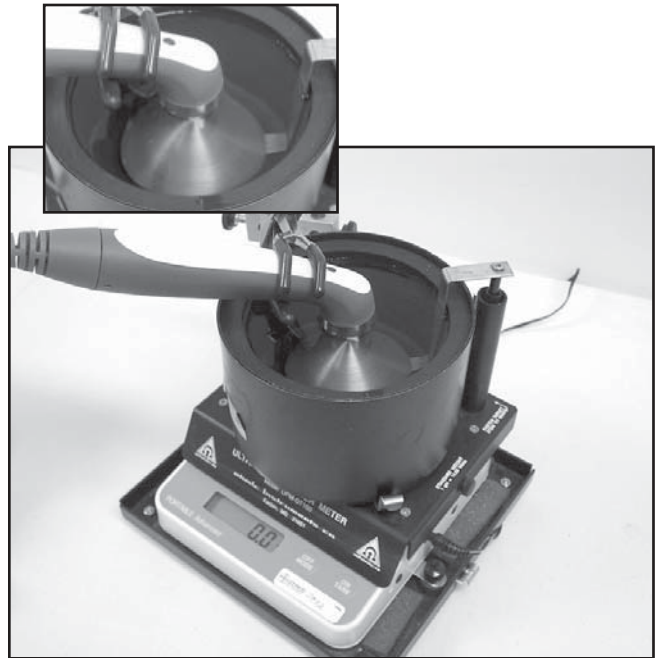

FIGURE 5.23

! WARNING

USE ONLY DEGASSED WATER IN POWER METER FOR TESTING ULTRASOUND APPLICATORS. USE OF OTHER TYPES OF WATER WILL CAUSE FALSE TEST RESULTS. **SEE PAGE 37** FOR DEGASSED WATER RECIPES.
DO NOT AERATE WATER WHEN FILLING POWER METER

APPLICATOR OUTPUT SPECIFICATIONS		
APPLICATOR SIZE	DUTY CYCLE	OUTPUT RANGE
5 cm ²	10%	0.8 - 1.2
	20%	1.6 - 2.4
	50%	4.0 - 6.0
	100% (Continuous)	8.0 - 12.0

FIGURE 5.24

5.18 COMBO OPERATION TEST

This test is performed using the 5 cm² Applicator.

Select Channel 2 and set up System per **5.6 parts A and B** prior to performing tests.

Connect Vectra Genisys, Intelect Legend XT or Intelect Vet 5 cm² Applicator to the System. **See Figure 5.25.** Applicator LED will flash green five times.

A. Combo Operation Test Procedures

1. Set Scope; Time- 50 μ S, Channel- 20 V, and Trigger- DC.
2. Press Combination Button. Press Edit Button.
3. Press Display Button until "Watts" is displayed within Display icon.
4. Press Select Waveform Button.
5. Press the Up or Down Arrow Button until IFC-4p is highlighted. Press the Accept and Return Arrow Button.
6. Press Edit Stim Button and rotate Intensity Control clockwise until "50 50" (mA) is displayed in "Amplitude Ch. 1 & 2" icon.
7. Press "Start".
8. Touch the Ultrasound Applicator to the Combo Contact on the ESTI-2 Load Test Fixture. The Combo Indicator on the ESTI-2 should illuminate, **See Figure 5.26.**
9. Compare waveform on scope to **Figure 5.27.**

B. Combo Operation Test Results

1. Waveform on scope the same as **Figure 5.27** and the Combo Indicator illuminates. Unit passed test.
2. No waveform or considerably different waveform. Unit failed test. Check appropriate Stim Board.

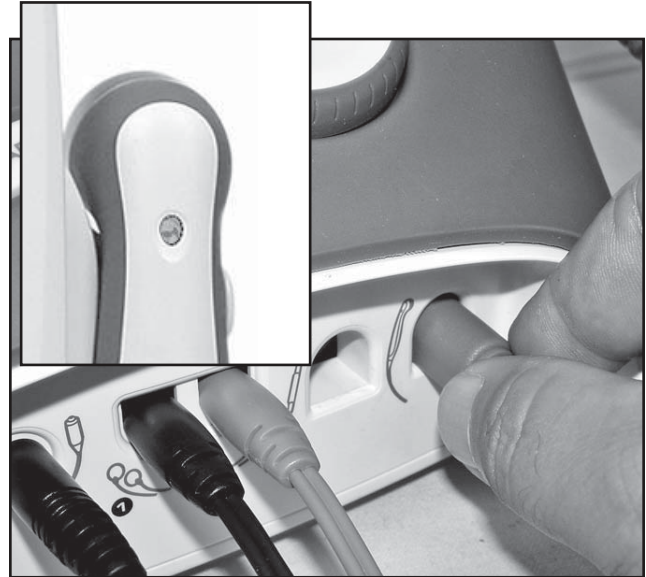

FIGURE 5.25

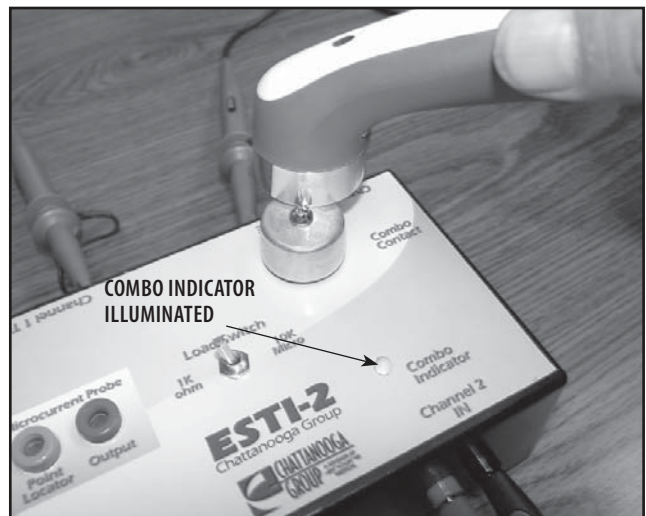

FIGURE 5.26

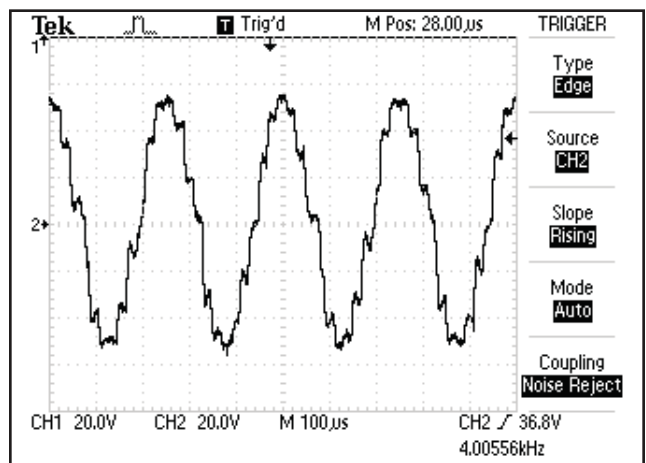

FIGURE 5.27

5.19 SEMG AND SEMG + ELECTRICAL STIMULATION TESTS

NOTE:

This test is for only the Vectra Genisys Therapy System with properly installed sEMG.

Perform this test on all Channels with sEMG. However, only one channel at a time can be tested with the Test Equipment described in this section.

A. Test Equipment Required

1. It will be necessary to build an Attenuator for this test. **See Figure 5.28** for schematic of the required Attenuator.
2. Calibrated Audio Signal Generator, B-K Precision, Model 3001.
3. Test leads for Audio Generator to Attenuator.

NOTE:

Audio Signal Generator must produce a sine waveform.

4. Known good set of sEMG Lead Wires.

B. sEMG Test Procedures

1. Set up Audio Signal Generator as follows:
 - a) Plug the Audio Signal Generator Test Leads into Generator SYNC Ports.
 - b) Set the **FREQ. RANGE** Hz to X1.
 - c) Turn the amplitude knob up to maximum.
 - d) Set the **WAVEFORM** to Sine waveform.
 - e) Set the **ATTEN** to O.
 - f) Set the **FREQUENCY DIAL** to 100.
 - g) Turn Audio Signal Generator On.

See Figure 5.29 for b-g.

1. Turn System On. View Home Screen for the presence of the sEMG and the sEMG + Stim icons. **See Figure 5.30**. If icons are not visible, stop test and make necessary repairs to the sEMG Module and System.

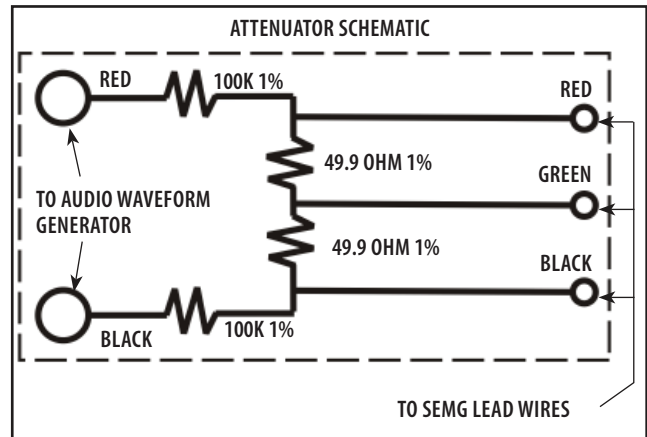

FIGURE 5.28

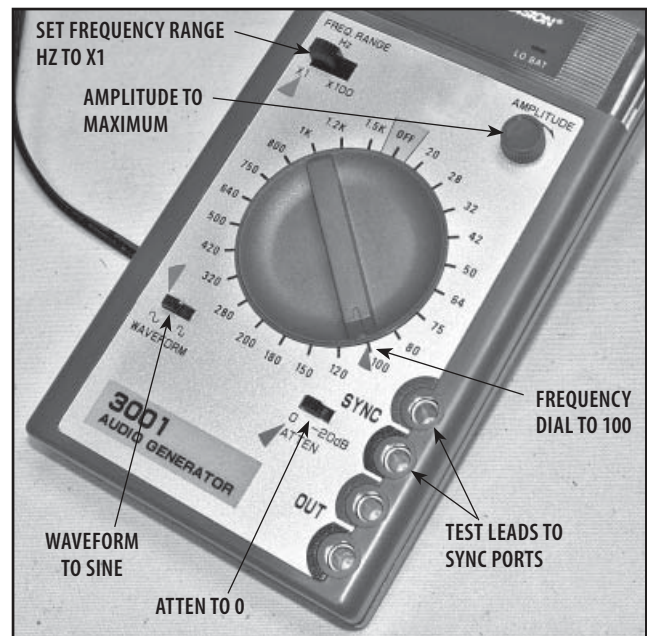

FIGURE 5.29

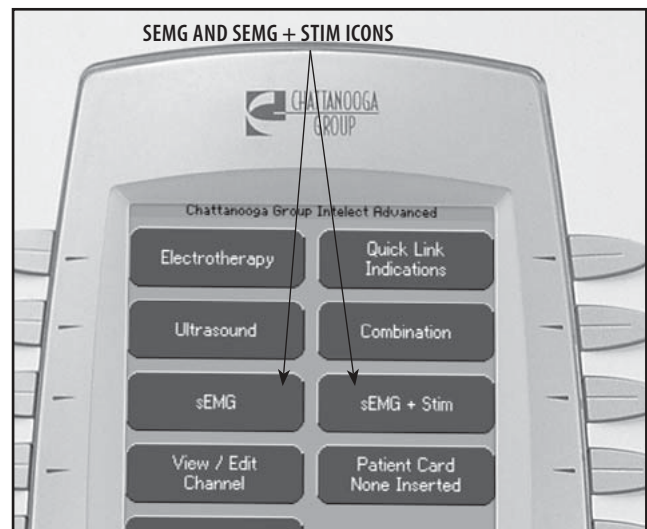

FIGURE 5.30

5.19 SEMG AND SEMG + ELECTRICAL STIMULATION TESTS (CONTINUED)

2. If icons are present, connect known good sEMG Lead Wire to Channels 1 and 2. See **Figure 5.31**.

NOTE:

Only one Channel at a time can be tested for sEMG.



FIGURE 5.31

3. Connect the Channel 1 sEMG lead wires into the Attenuator. Make certain each sEMG Lead is connected to its respective color on the Attenuator. See **Figure 5.32**.

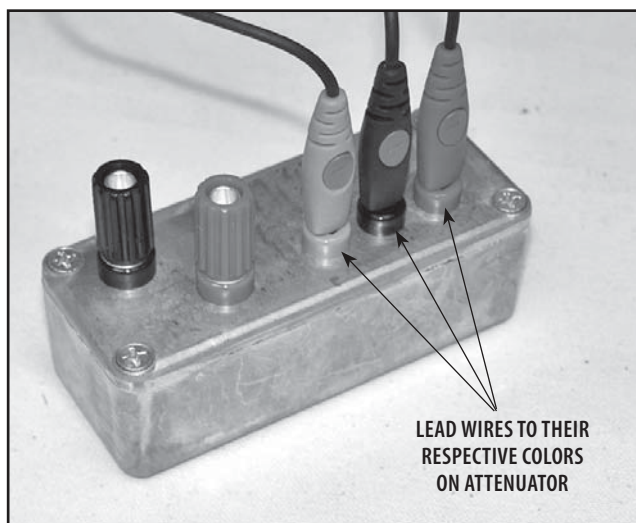

FIGURE 5.32

4. Press the sEMG Button on Home Screen. Channel 1 should read 7 or less. See **Figure 5.33**.
5. If Channel 1 reads less than 7, repeat **steps 2 through 5** on Channel 2. If any Channel being tested reads greater than 7, replace the sEMG Module and re-test.

NOTE:

The reading on the Channel not being tested may vary in its reading. This is insignificant as it is not under load.

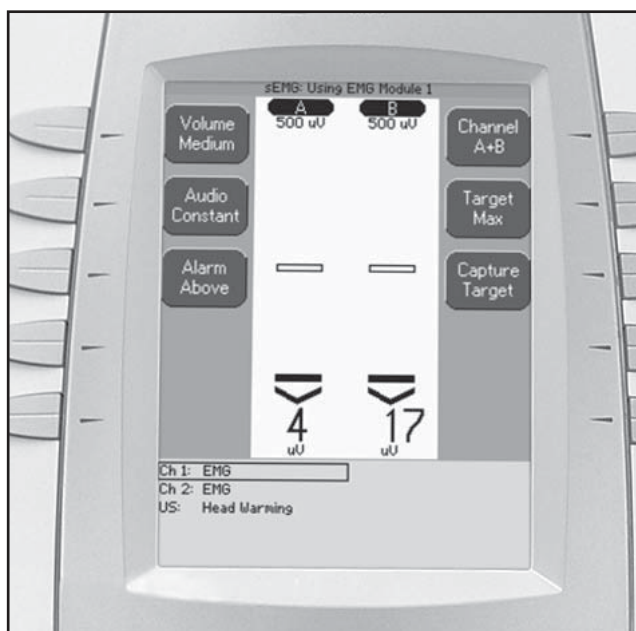

FIGURE 5.33

5.19 SEMG AND SEMG + ELECTRICAL STIMULATION TESTS (CONTINUED)

7. Make certain the Audio Signal Generator is set up per **5.19, part B, steps 1, a) through 1, g)**. Connect the Audio Signal Generator Test Leads from the Generator SYNC Ports to the Attenuator (make certain test leads are connected red to red and black to black). **See Figure 5.34.**
8. Connect the sEMG Lead Wire to Channel 1.
9. View the System sEMG Screen. Channel 1 should read between 604 and 738. **See Figure 5.35.**

Test all sEMG Channels. If any Channel being tested reads below 604 or greater than 738, replace the respective sEMG Module and re-test.

NOTE:

The reading on the Channel not being tested may vary in its reading. This is insignificant as it is not under load.

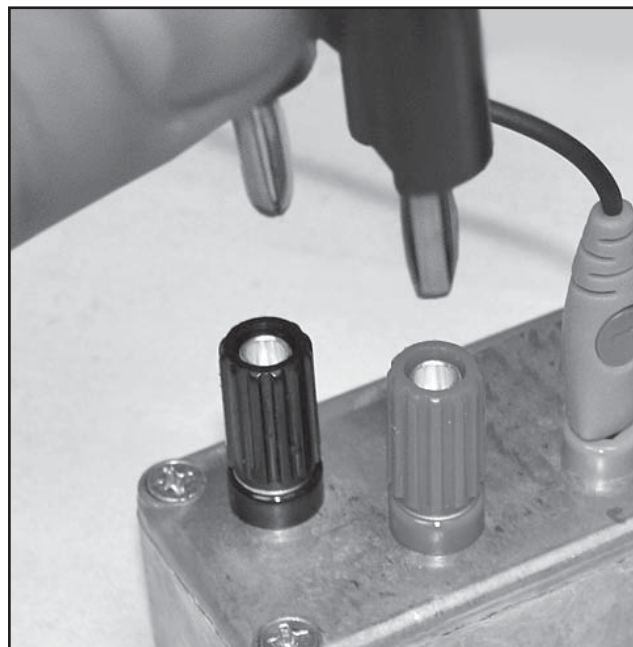

FIGURE 5.34

C. sEMG Test Results

If any sEMG Channel fails any part of the tests as described in **5.19, B, steps 2 through 9**, then the module fails the test.

1. Make certain the sEMG Module is completely seated in system housing and all contacts between Stim Board and sEMG Module are making proper contact.
2. Replace the respective sEMG Module and re-test.
3. Replace the respective Stim Board and re-test.
4. Replace the Control Board and re-test.

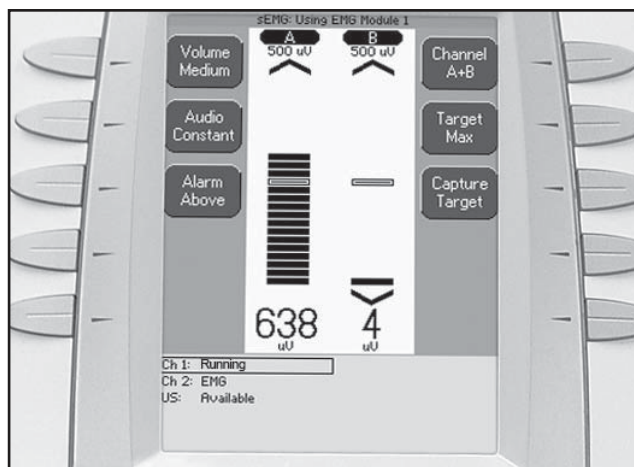

FIGURE 5.35

5.19 SEMG AND SEMG + ELECTRICAL STIMULATION TESTS (CONTINUED)

D. sEMG + STIM Tests

1. To Check Stim Output, conduct the Electrical Stimulator Tests as explained in **5.6 through 5.13**.
2. Set up Signal Generator and Attenuator as described in **5.19, part B**.
3. Select sEMG + Stim on the Therapy System Home Screen.
4. Press Edit Button (software Version 2.0 and above).
5. Press Stim button on Therapy System Home Screen.
6. Press the Up or Down Arrow button until "Sym Biph" is highlighted. Press the Accept and Return Arrow button.
7. Press the Edit Stim button.
8. Rotate Treatment Intensity Knob until 5.0 mA CC is displayed. Then press the Back button.
9. Press Start sEMG + Stim button.
10. The Audio Signal Generator and the attenuator should trigger the stim function of the Therapy System and Running will display in the selected channel. **See Figure 5.35A.**

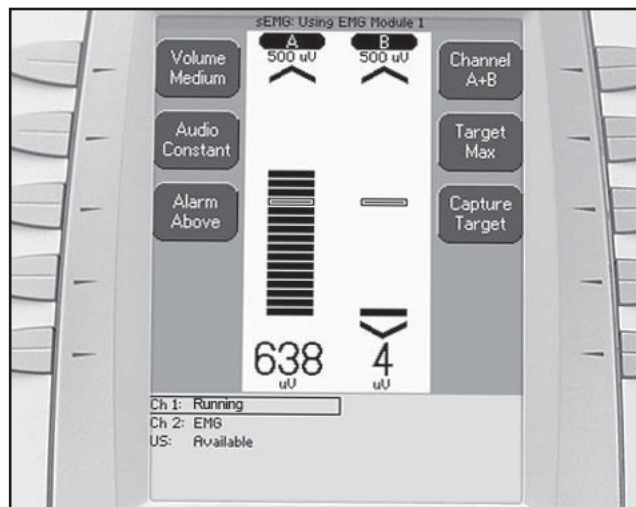

FIGURE 5.35A

E. sEMG + Stim Test Results

1. Stim function is triggered. System passed test.
2. Stim function is not triggered. System Failed Test
Replace appropriate Stim Board.

NOTE:

Test all sEMG Channels for proper triggering of Stim function.

5.20 NIMH BATTERY MODULE CHECKS

The following checks for the NiMH Battery Module are to check for possible damage to the Battery Cells and proper connections within the module and module to System connection.

A. Tools and Equipment Required

1. #1 Phillips Screwdriver
2. Flat Blade Screwdriver

B. NiMH Battery Module Check Procedures

NOTE:

If it is suspected that the NiMH Battery cells may be damaged or leaking, perform **steps 8 through 13** prior to any other tests or checks.

1. With the NiMH Battery Module properly installed onto the System, connect System Mains Power Cord to an approved electrical outlet.
2. Turn system On and view the Home Screen. The Charge Level and Battery Charging icons should appear in the lower left corner of the Home Screen. See **Figure 5.36**.

NOTE:

If Battery Module is fully charged, the Battery Charging Icon will not be visible and the Charge Level Icon will be fully black. If battery is fully charged, perform **steps 4 through 7** below then perform **step 3**.

3. Allow battery to charge until it can be verified that it is charging by viewing the Charge Level icon until the level indicator fills more of the Charge Level icon.
4. Set up the Ultrasound Test as described in **5.16**. Set Duty Cycle to 100%. Set Display to Watts, rotate Therapy Intensity knob until 10.0 Watts is visible, set Treatment Time to 60 minutes.
5. Disconnect System Mains Power Cord from wall power outlet.
6. With Ultrasound Applicator Sound Head submerged in the Power Meter degassed water, press start.
7. View the Charge Level Icon until it reduces the fill area of the icon. This verifies proper discharging of the battery module.
8. Turn System Off and remove the NiMH Battery Module from the System. Refer to the proper Removal & Replacement section for instructions.
9. Using the #1 Phillips Screwdriver, remove the two retaining screws in the top of the NiMH Battery Module. See **Figure 5.37**.

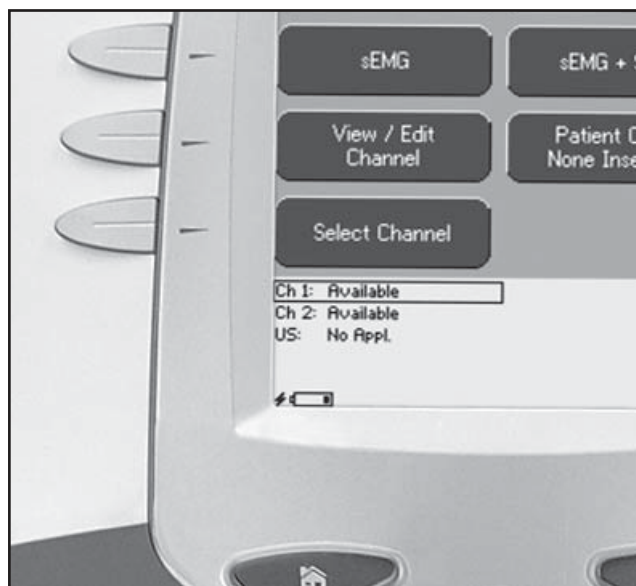

FIGURE 5.36

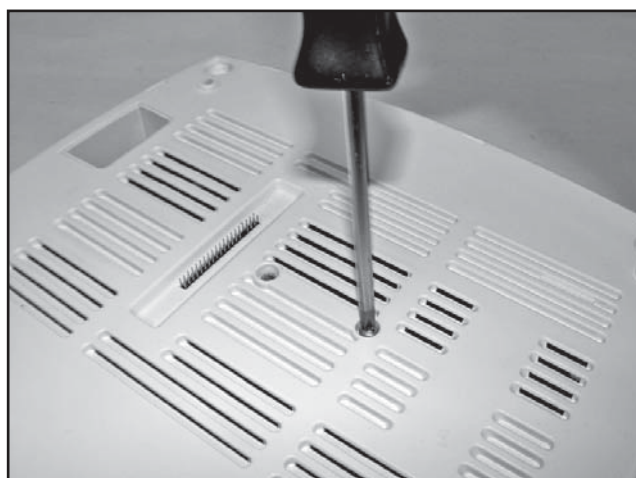

FIGURE 5.37

5.20 NIMH BATTERY MODULE CHECKS (CONTINUED)

10. Using the Flat Blade Screwdriver, carefully release the tabs retaining the top plate in position. It will be necessary to lift with one hand while releasing the tabs with the Screwdriver. **See Figure 5.38.**

NOTE:

There are eight retaining tabs. All must be released as shown in **Figure 5.38.**

11. Lift the PC Board and check the Battery Packs to PC Board connection to ensure it is completely seated. **See Figure 5.39.**
12. Visually Inspect individual cells of both battery packs for leaks or ruptures. **See Figure 5.40.**
13. Reassemble the battery Module. Do not over tighten the two retaining screws in the module top. Over tightening may damage the threaded brass inserts of the housing.

C. NiMH Battery Module Checks Results

1. Should any check fail, replace the entire module. No component parts are or will be made available for the Battery Module by Chattanooga Group.
2. If the problem persists, replace the Control Board.



FIGURE 5.38

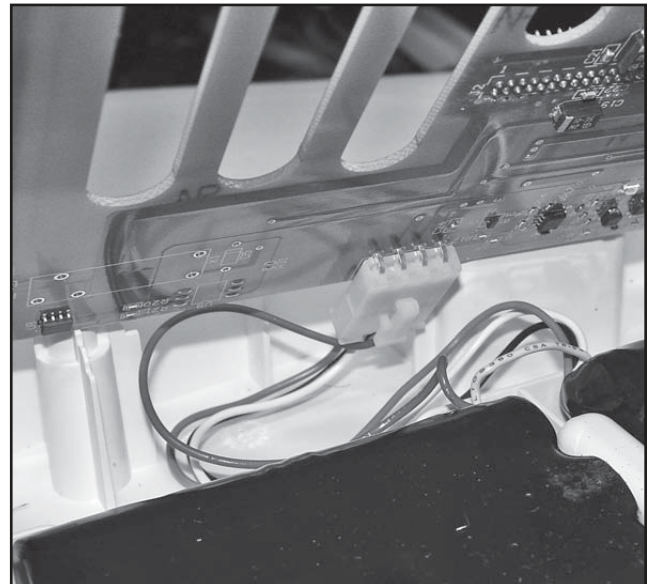

FIGURE 5.39

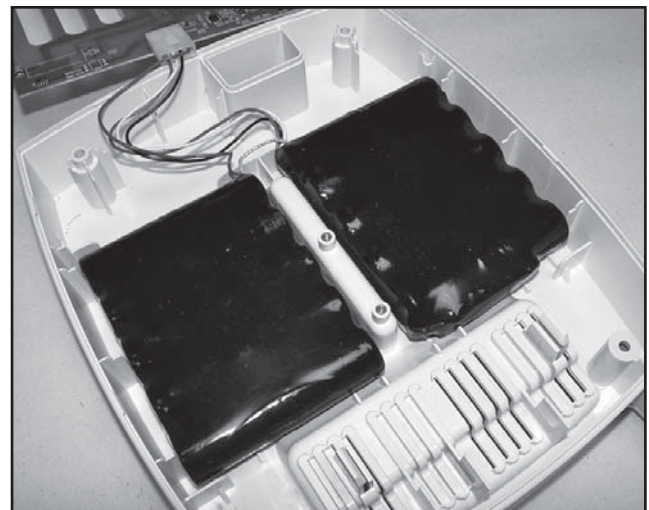

FIGURE 5.40

DANGER



- NiMH batteries contain Class E corrosive materials. In the event of battery cell rupture or leakage, handle battery module wearing neoprene or natural rubber gloves. Contents of a ruptured or leaking battery can cause respiratory irritation. Hypersensitivity to nickel can cause allergic pulmonary asthma. Contents of cell coming in contact with skin can cause skin irritation and chemical burns.
- Never, under any circumstances, open the battery cells. Should an individual cell from a battery become disassembled, spontaneous combustion of the negative electrode is possible. There can be a delay between exposure to air and spontaneous combustion.



6- REMOVAL/REPLACEMENT

6.1 CHANNEL 3/4 ELECTROTHERAPY, NIMH BATTERY, AND LASER MODULE INSTALLATION AND REMOVAL

WARNING

DISCONNECT THE SYSTEM FROM THE POWER SOURCE (OUTLET OR REMOVE BATTERY MODULE IF INSTALLED) BEFORE ATTEMPTING ANY MAINTENANCE, INSTALLATION, REMOVAL, OR REPLACEMENT PROCEDURES TO PREVENT ELECTRICAL SHOCK AND POSSIBLE DAMAGE TO SYSTEM.

A. Tools & Equipment Required

1. #1 Phillips Screwdriver
2. Flat Blade Screwdriver
3. Needle Nose Pliers

The following procedures apply to all Channel 3/4 Electrotherapy, NiMH Battery, and Laser Modules (Vectra Genisys and Intellect Vet) that mount to the base of a Therapy System.

B. Module Installation

1. Disconnect Therapy System from the power source.
2. Remove the Rear Panel and disconnect the Power Cord from the System. **See Figure 6.1.**
3. Place system on a level working surface.
4. Remove the Front Access Panel and disconnect all existing cables and Lead Wires. **See Figure 6.2.**
5. Using a #1 Phillips Screwdriver, remove the screw securing the Lanyard to the Front Access Panel. **See Figure 6.3.**

NOTE:

When turning over Therapy System onto its face, place a clean, soft cloth under the lens to prevent scratching or lens damage. If the system is equipped with an sEMG Module, leave it in place to maintain sEMG functions for Channels 1 and 2. The sEMG Module will not interfere with installation of a Module to the Therapy System.

6. Turn system over, remove the label covering the Ribbon Cable and unroll Ribbon Cable. **See Figure 6.4.**

CAUTION

Be careful not to disconnect the Ribbon Cable from the Vectra Genisys, Intellect Legend XT and Intellect Vet Therapy Systems.

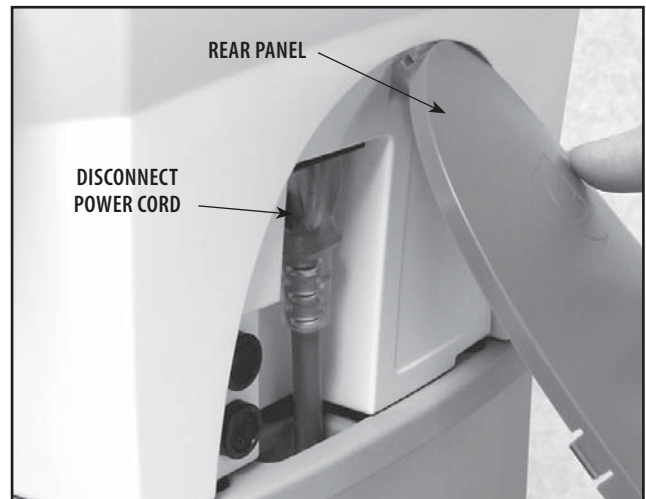

FIGURE 6.1

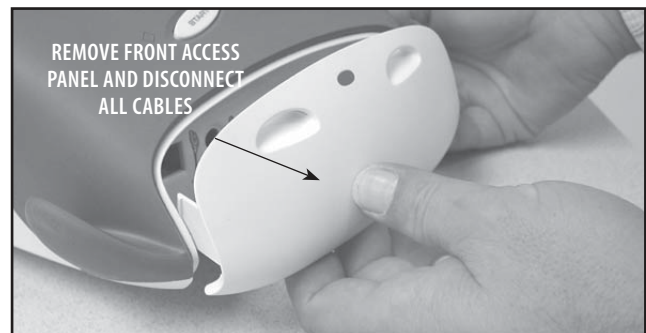

FIGURE 6.2

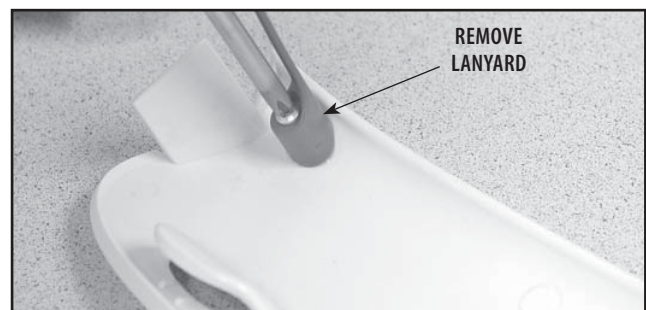

FIGURE 6.3

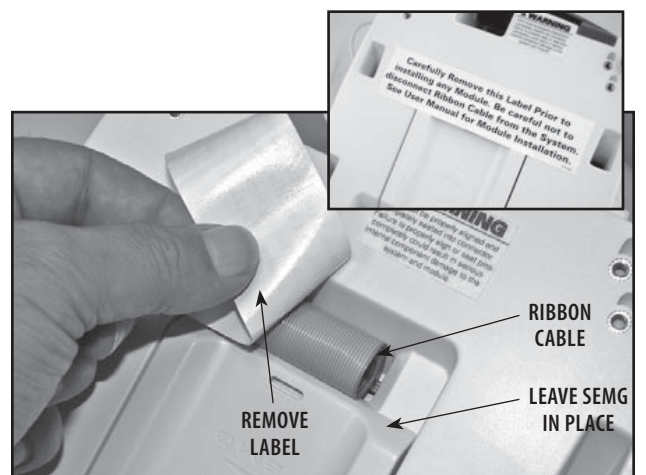

FIGURE 6.4

6- REMOVAL/REPLACEMENT

6.1 CHANNEL 3/4 ELECTROTHERAPY, NIMH BATTERY, AND LASER MODULE INSTALLATION AND REMOVAL (CONTINUED)

WARNING

DISCONNECT THE SYSTEM FROM THE POWER SOURCE (OUTLET OR REMOVE BATTERY MODULE IF INSTALLED) BEFORE ATTEMPTING ANY MAINTENANCE, INSTALLATION, REMOVAL, OR REPLACEMENT PROCEDURES TO PREVENT ELECTRICAL SHOCK AND POSSIBLE DAMAGE TO SYSTEM.

Lay Therapy System on its side and position the Module to be installed beside it. Install Ribbon Cable to Module and seat completely on module pins. Make certain the Blue Strip on Ribbon Cable is positioned as shown in **Figure 6.5**.

CAUTION

DO NOT TWIST RIBBON CABLE!

If Ribbon Cable is twisted, the pins will not properly align. If power is applied to the system with misalignment of pins or a twisted ribbon cable, the controlling electronics in the Module will be destroyed and possible damage to the System internal components could occur.

7. Position Therapy System over Module as shown in **Figure 6.6**. Align Therapy System Feet with Module Indentions. **RIBBON CABLE MUST BE POSITIONED AS SHOWN!**
8. Place System onto Module making certain the System Feet are within the Module Indentions.

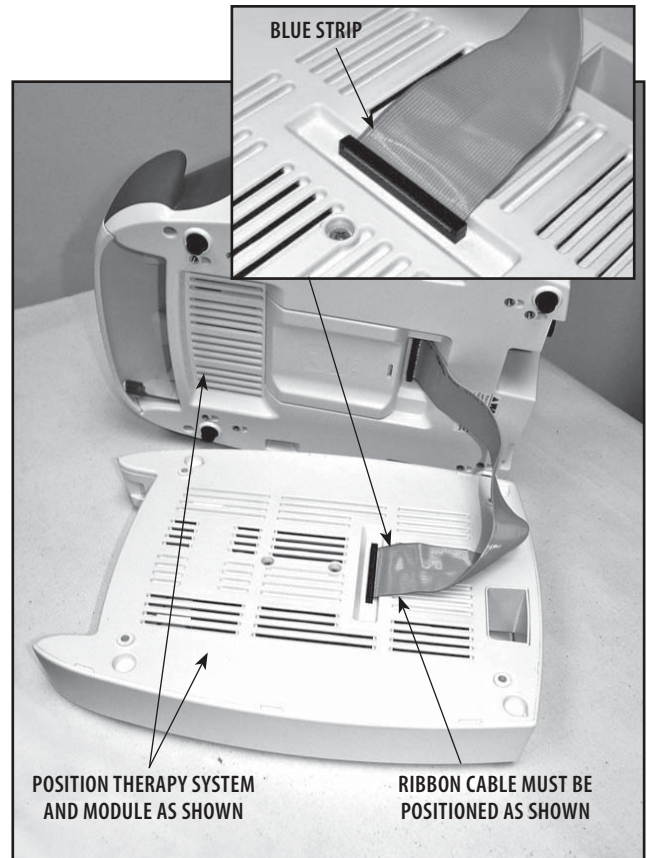

FIGURE 6.5

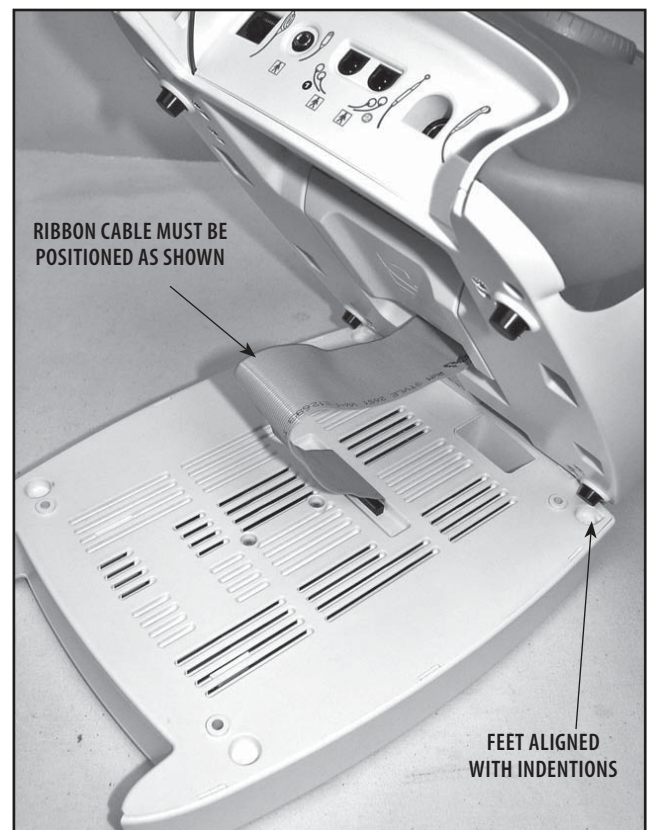

FIGURE 6.6

6- REMOVAL/REPLACEMENT

6.1 CHANNEL 3/4 ELECTROTHERAPY, NIMH BATTERY, AND LASER MODULE INSTALLATION AND REMOVAL (CONTINUED)

WARNING

DISCONNECT THE SYSTEM FROM THE POWER SOURCE (OUTLET OR REMOVE BATTERY MODULE IF INSTALLED) BEFORE ATTEMPTING ANY MAINTENANCE, INSTALLATION, REMOVAL, OR REPLACEMENT PROCEDURES TO PREVENT ELECTRICAL SHOCK AND POSSIBLE DAMAGE TO SYSTEM.

9. Holding Module to System, position both on one side and secure the Module to the System with four 4 mm x 20 mm Screws. **See Figure 6.7.** Tighten only enough to prevent Module from shifting on Therapy System.
10. Set the assembly upright on the work surface and install the new Extended Front Access Panel to the Lanyard. **See Figure 6.8.**
NOTE:
When mounting the Front Access Panel to the Therapy System, make certain the Lanyard does not become kinked.



FIGURE 6.7

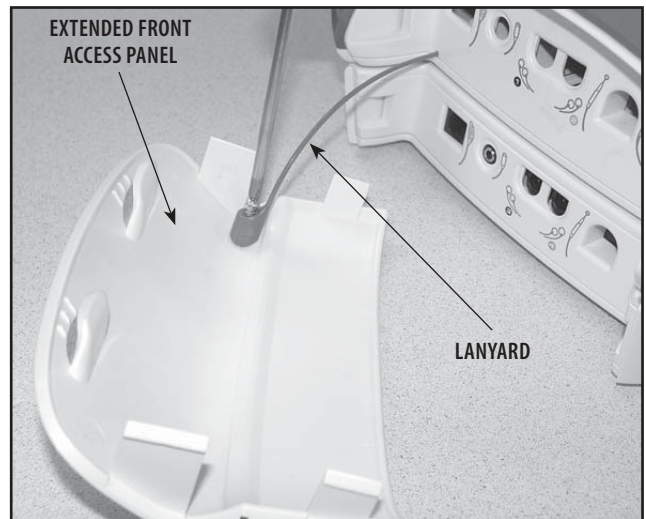

FIGURE 6.8

11. Route Power Cord through Module to Therapy System. **See Figure 6.9.** Re-install Rear Panel. Plug Power Cord into an approved power outlet.
NOTE:
If installing Therapy System with Module to a Therapy System Cart, refer to the Therapy System Cart Installation instructions.

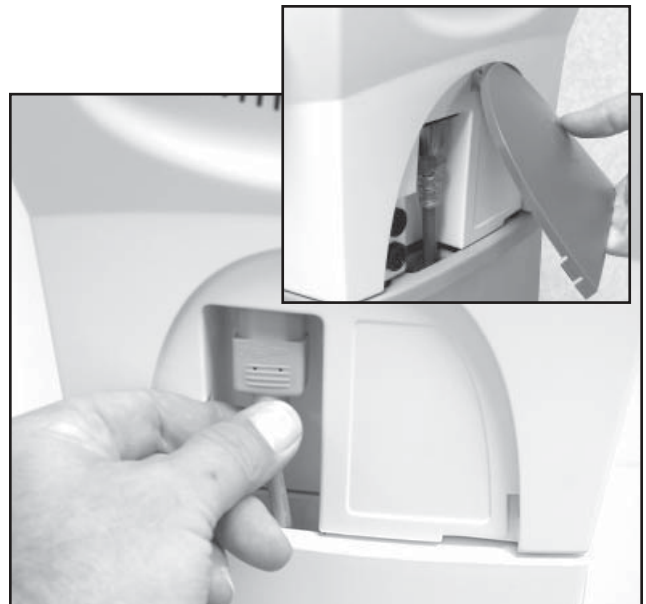

FIGURE 6.9

6.1 CHANNEL 3/4 ELECTROTHERAPY, NIMH BATTERY, AND LASER MODULE INSTALLATION AND REMOVAL (CONTINUED)

12. Install all cables, Lead Wires, etc. to the Therapy System and Module where applicable. Refer to page 14 for Symbol Definitions. See Figure 6.10.



FIGURE 6.10

13. Turn the System On using the On/Off Switch. The system will automatically recognize the added module and display a configuration change message. See Figure 6.11.
14. Read and carefully follow the instructions on the Screen.

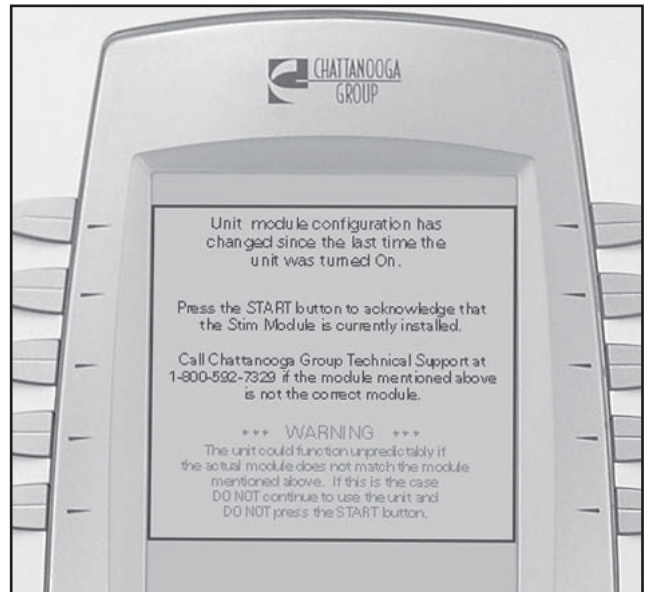

FIGURE 6.11

WARNING

Verify that the module installed is the module displayed in the message BEFORE pressing the START button. If it is not, DO NOT press the START button. Turn the system OFF and back ON. If the problem persists, call the dealer or Chattanooga Group Technical Support immediately. DO NOT USE THE SYSTEM until all necessary repairs are made by a Technician certified by Chattanooga Group. If use is attempted before repairs are made, the system may operate unpredictably and has the potential of causing injury to the patient or damage to the system internal components.

B. Module Removal

1. Remove Module in reverse order of installation beginning with **step A, 13**.
2. After module is removed, follow instructions in **steps A, 14 and A, 15**.

6.2 sEMG MODULE INSTALLATION AND REMOVAL (VECTRA GENISYS ONLY)

WARNING

- Disconnect the system from the power source (outlet or remove battery module if installed) before attempting any maintenance, installation, removal, or replacement procedures to prevent electrical shock and possible damage to system.
- Be careful not to damage the contacts of the sEMG Module, Therapy System, or Module Stim Board contacts.
- When installing sEMG, verify that the model number is capable of supporting the functions of sEMG.

A. Tools and Equipment Required

1. #1 Phillips Screwdriver
2. Flat Blade Screwdriver

B. sEMG Installation

NOTE:

If installing or replacing an sEMG Module on a Therapy System with a Channel 3/4 Electrotherapy Module, Battery Module, or Laser Module already installed, and the sEMG functions are desired for Channels 1 and 2, it will be necessary to remove the module from the system. **Refer to 6.1, B** for instructions.

If replacing or installing an sEMG Module to a Therapy System with a Channel 3/4 Electrotherapy Module, and it is desired that sEMG function be available to Channels 3 and 4, it will not be necessary to remove the module as it will be installed to the Module.

The sEMG Module can only be installed on the Therapy System and Channel 3/4 Electrotherapy Module. This allows a maximum of two sEMG modules on a four channel Electrotherapy or Combination Therapy System. An sEMG Module cannot be installed on the NiMH Battery or Laser Module.

Only two channels of sEMG can be used at any given time even if the Therapy System is equipped with two sEMG Modules.

1. Disconnect Power Cord from the power source and turn system over on its face.

NOTE:

When turning over Therapy System onto its face, place a clean, soft cloth under the lens to prevent scratching or lens damage.

NOTE:

Twist the Screwdriver to break tabs free. Carefully remove tabs so as not to cause any damage to the PC Board Contacts below the tabs. If installing on the Channel 3/4 Electrotherapy Module, remove tabs from the Module in the same manner.

2. Using a Flat Blade Screwdriver, carefully remove the four breakout tabs on the System bottom. **See Figure 6.12.**

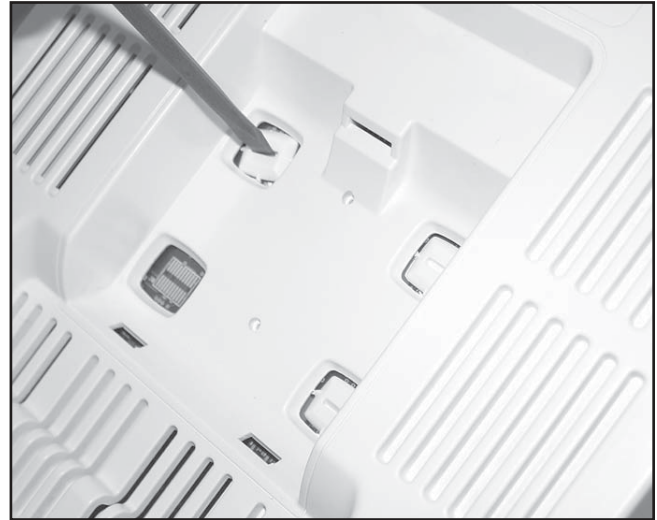

FIGURE 6.12

6- REMOVAL/REPLACEMENT

6.2 sEMG MODULE INSTALLATION AND REMOVAL (VECTRA GENISYS ONLY) (CONTINUED)



WARNING

DISCONNECT THE SYSTEM FROM THE POWER SOURCE (OUTLET OR REMOVE BATTERY MODULE IF INSTALLED) BEFORE ATTEMPTING ANY MAINTENANCE, INSTALLATION, REMOVAL, OR REPLACEMENT PROCEDURES TO PREVENT ELECTRICAL SHOCK AND POSSIBLE DAMAGE TO SYSTEM.

3. Position the Surface EMG Module so that the two mounting tabs are inserted into the System or Electrotherapy Module mounting slots. **See Figure 6.13.**
4. Push the upper portion of the sEMG Module until it snaps and is locked into position. **See Figure 6.14.**
5. Re-install module if required. **Refer to 6.2.**



FIGURE 6.13



FIGURE 6.14

6. Route Power Cord through the Module and connect to the Therapy System. Install all cables, Lead Wires, etc. to the Therapy System and Module where applicable. Refer to **page 17** for symbol definitions. **See Figure 6.15.**

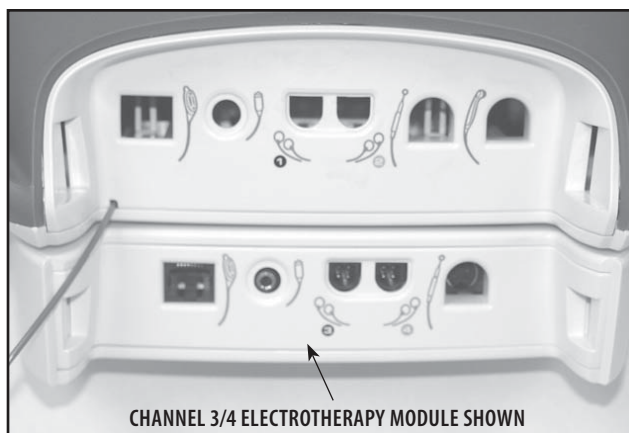



FIGURE 6.15

6.2 sEMG MODULE INSTALLATION AND REMOVAL (VECTRA GENISYS ONLY) (CONTINUED)

7. Turn the System On using the On/Off Switch. The system will automatically recognize the added module and display a configuration change message. See Figure 6.16.

 **WARNING**

Verify that the module installed is the module displayed in the message BEFORE pressing the START button. If it is not, DO NOT press the START button. Turn the system OFF and back ON. If the problem persists, call the dealer or Chattanooga Group Technical Support immediately. DO NOT USE THE SYSTEM until all necessary repairs are made by a Technician certified by Chattanooga Group. If use is attempted before repairs are made, the system may operate unpredictably and has the potential of causing injury to the patient or damage to the system internal components.

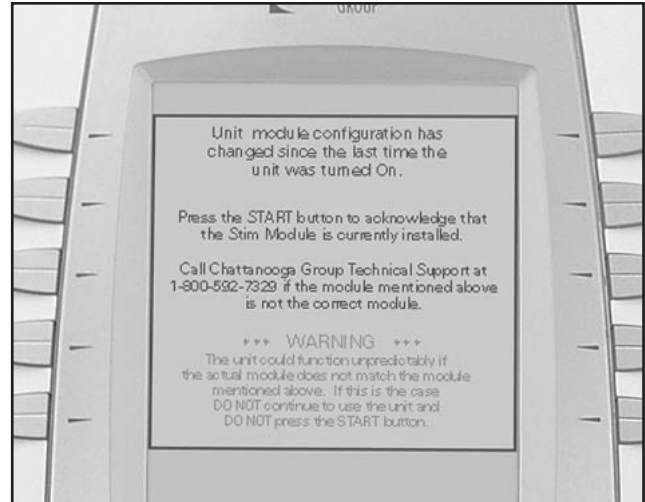

FIGURE 6.16

8. Read and carefully follow the instructions on the Screen.

C. Module Removal

1. Remove Module, if necessary, from Therapy System. Refer to 6.2, B for instructions.
2. Place a Flat Blade Screwdriver under the locking tab of the sEMG Module. Firmly push in and twist Screwdriver. The Module should release from the Therapy System. See Figure 6.17.

NOTE:

If no sEMG Module will be re-installed on the system. Install sEMG Plug Kit, part number 28027, to protect and cover the Stim Board contacts. The Therapy System may be placed back into service without an sEMG Module installed as long as the sEMG Plug Kit is installed to protect the PC Board contacts.

3. Refer to steps 7 and 8 to finalize removal.



FIGURE 6.17

6- REMOVAL/REPLACEMENT

6.3 THERAPY SYSTEM- SEPARATING TOP & BOTTOM

! WARNING

DISCONNECT THE SYSTEM FROM THE POWER SOURCE (OUTLET OR REMOVE BATTERY MODULE IF INSTALLED) BEFORE ATTEMPTING ANY MAINTENANCE, INSTALLATION, REMOVAL, OR REPLACEMENT PROCEDURES TO PREVENT ELECTRICAL SHOCK AND POSSIBLE DAMAGE TO SYSTEM.

A. Tools and Equipment Required

1. #1 Phillips Screwdriver
2. Flat Blade Screwdriver

B. Removing Top from Bottom

1. Place system face down on a soft work surface.
2. Remove any Module (NiMH Battery, Channel 3/4 Electrotherapy or Laser) from the System. **Refer to 6.2, part C** for instructions.
NOTE:
It is not necessary to remove an sEMG Module from the System unless the Stim Board is being replaced.
3. Remove the four mounting screws securing the top and bottom together. **See Figure 6.18.**
4. Turn System over on its feet and carefully separate the System Top from the Bottom Housing.
NOTE:
On Combination Systems, it may be necessary to use a Flat Blade Screwdriver around the Ultrasound Applicator Rest to separate the top from the bottom. **See Figure 6.19.**
5. Raise the System Top and disconnect the Control Board Ribbon Cable from the Stim Board or Ultrasound Board on Combination Systems. **See Figure 6.20.**

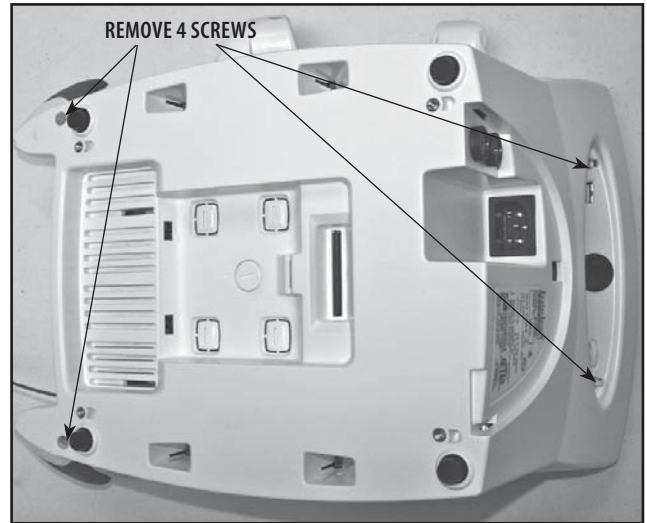

FIGURE 6.18



FIGURE 6.19

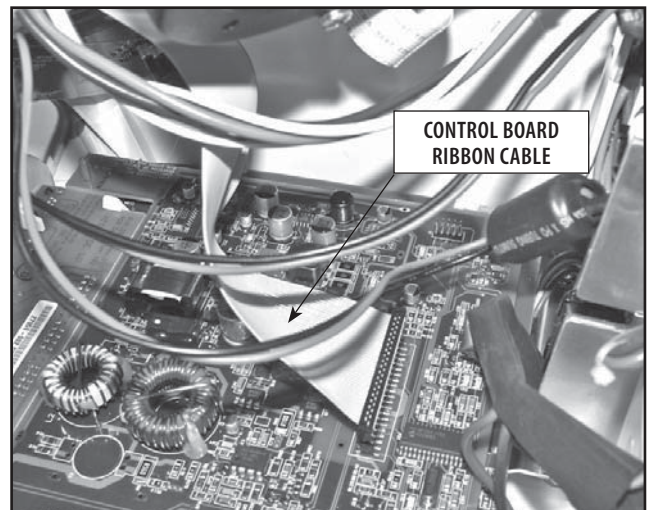

FIGURE 6.20

6.3 THERAPY SYSTEM- SEPARATING TOP & BOTTOM (CONTINUED)

WARNING

DISCONNECT THE SYSTEM FROM THE POWER SOURCE (OUTLET OR REMOVE BATTERY MODULE IF INSTALLED) BEFORE ATTEMPTING ANY MAINTENANCE, INSTALLATION, REMOVAL, OR REPLACEMENT PROCEDURES TO PREVENT ELECTRICAL SHOCK AND POSSIBLE DAMAGE TO SYSTEM.

6. Lay System Top on the edge and disconnect the remaining harnesses from the Control Board. **See Figure 6.21.**

C. Replacing Top to Bottom

Replace System Top by reversing the **steps 1-5 on page 66.**

NOTE:

Do not over tighten the screws. Over tightening will damage the threads of the brass inserts.

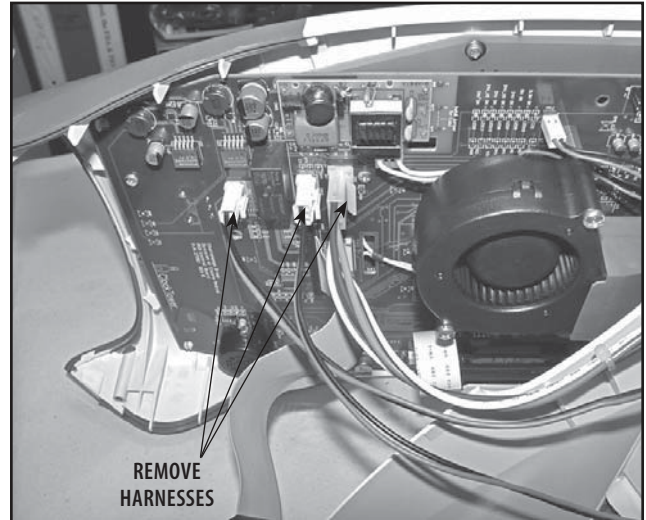

FIGURE 6.21

6- REMOVAL/REPLACEMENT

6.4 THERAPY SYSTEM- FAN

WARNING

DISCONNECT THE SYSTEM FROM THE POWER SOURCE (OUTLET OR REMOVE BATTERY MODULE IF INSTALLED) BEFORE ATTEMPTING ANY MAINTENANCE, INSTALLATION, REMOVAL, OR REPLACEMENT PROCEDURES TO PREVENT ELECTRICAL SHOCK AND POSSIBLE DAMAGE TO SYSTEM.

A. Tools and Equipment Required

#1 Phillips Screwdriver

B. Therapy System Fan Removal

1. Separate Top from Bottom. Refer to 6.3, part B.
2. Using a #1 Phillips Screwdriver, remove the Two Fan Retaining Screws securing the Fan to the System Top. See Figure 6.22.
3. Remove the Fan Harness from the Control Board. See Figure 6.23.

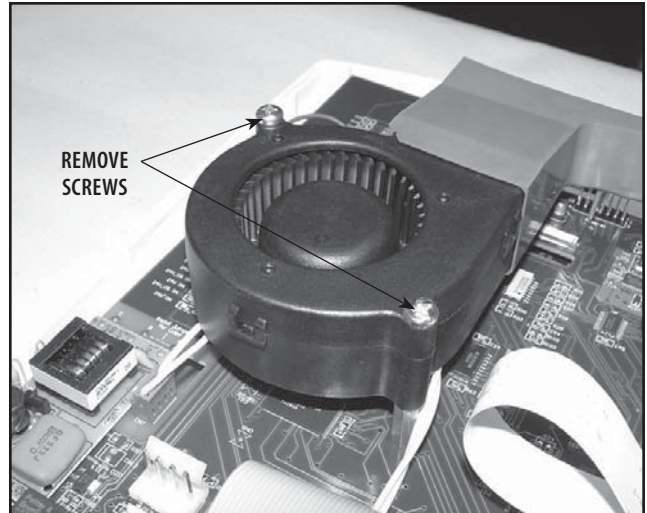

FIGURE 6.22

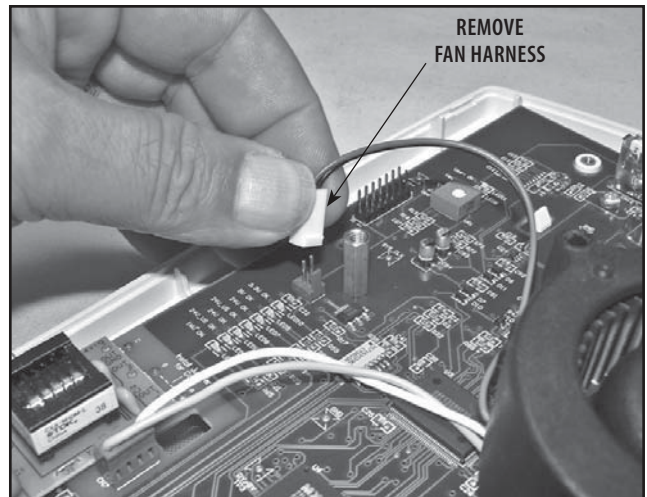

FIGURE 6.23

4. Remove the Fan Baffle from the Fan Housing. See Figure 6.24.

C. Replacing Fan

1. Replace new Fan, part number 27158 by reversing the steps 1- 3 above.

NOTE:

Do not over tighten the screws. Over tightening will damage the threads of the brass standoffs.

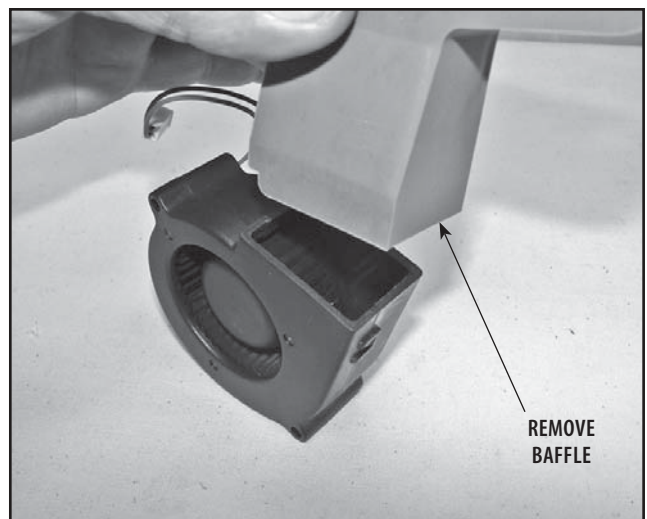

FIGURE 6.24

6- REMOVAL/REPLACEMENT

6.5 THERAPY SYSTEM- CONTROL BOARD ASSEMBLY

WARNING

DISCONNECT THE SYSTEM FROM THE POWER SOURCE (OUTLET OR REMOVE BATTERY MODULE IF INSTALLED) BEFORE ATTEMPTING ANY MAINTENANCE, INSTALLATION, REMOVAL, OR REPLACEMENT PROCEDURES TO PREVENT ELECTRICAL SHOCK AND POSSIBLE DAMAGE TO SYSTEM.

A. Tools and Equipment Required

1. #1 Phillips Screwdriver
2. Needle Nose Pliers

B. Control Board Assembly Removal

1. Separate Top from Bottom. Refer to 6.3, part B.
2. Remove Fan. Refer to 6.4, part B.
3. Remove the Contrast Knob. See Figure 6.25.
4. Remove the Control Board Ribbon Cable and the two Control Board Assembly Retaining Screws. See Figure 6.26.
5. Starting at the top of the Control Board Assembly, lift Control Board with one hand, push in and release the plastic clips holding Control Board Assembly in position. See Figure 6.27.
6. While holding up on Control Board Assembly, use the Needle Nose Pliers to squeeze the lower plastic retainers holding the bottom of the Control Board. See Figure 6.27 inset.
7. Remove the Card Reader Housing from the Control Board Assembly.

C. Replacing Control Board Assembly

1. Replace new Control Board Assembly, part number 27053 by reversing the steps 1- 7 above.

NOTE:

Do not over tighten the screws. Over tightening will damage the threads of the brass inserts.

2. Install Therapy Intensity Control Knob on the front side of Therapy System Top.
3. Re-assemble Therapy System referring to the appropriate sections of this manual for proper instructions.

WARNING

MAKE CERTAIN THE CONTROL BOARD RIBBON CABLE IS INSTALLED WITH THE BLACK STRIP AT THE NUMBER "1" ON THE CONTROL BOARD. FAILURE TO PROPERLY INSTALL RIBBON CABLE COULD CAUSE EXTENSIVE DAMAGE TO THE INTERNAL COMPONENTS OF THE SYSTEM WHEN TURNED ON.

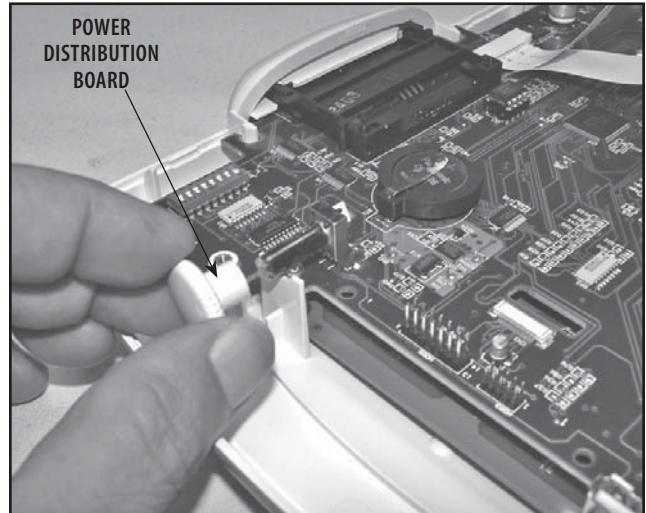

FIGURE 6.25

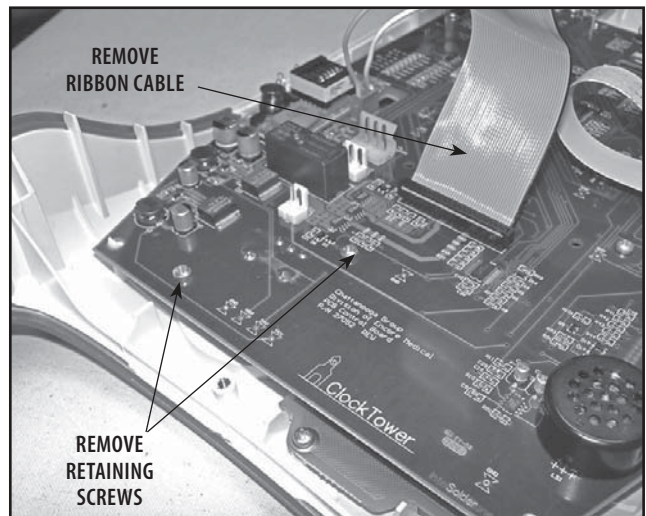

FIGURE 6.26

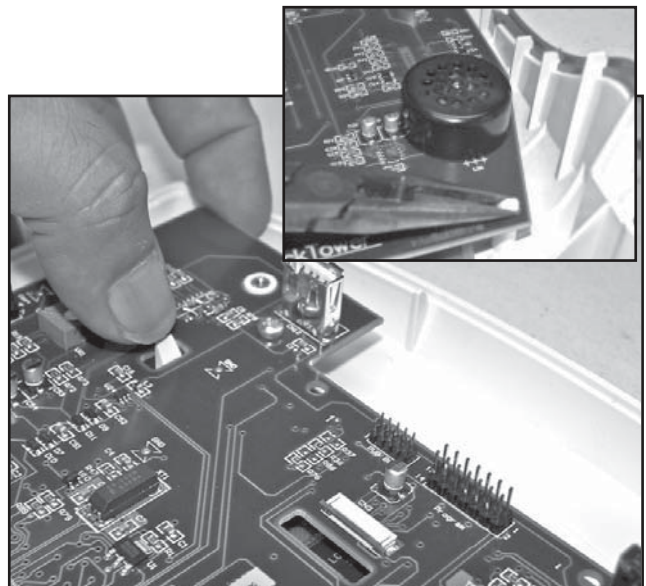

FIGURE 6.27

6- REMOVAL/REPLACEMENT

6.6 THERAPY SYSTEM- KEYMAT ASSEMBLY

WARNING

DISCONNECT THE SYSTEM FROM THE POWER SOURCE (OUTLET OR REMOVE BATTERY MODULE IF INSTALLED) BEFORE ATTEMPTING ANY MAINTENANCE, INSTALLATION, REMOVAL, OR REPLACEMENT PROCEDURES TO PREVENT ELECTRICAL SHOCK AND POSSIBLE DAMAGE TO SYSTEM.

A. Tools and Equipment Required

1. #1 Phillips Screwdriver
2. Needle Nose Pliers

B. Keymat Assembly Removal

1. Separate Top from Bottom. Refer to 6.3, part B.
2. Remove Fan. Refer to 6.4, part B.
3. Remove Control Board Assembly. Refer to 6.5, part B.
4. Remove eight Keymat PC Board Retaining Screws. See Figure 6.28.
5. Starting at the top of the Keymat PC Board, lift board with one hand, push in and release the plastic clips holding the Keymat PC Board in position. See Figure 6.29.
6. Remove Keymats from the System Top. See Figure 6.30.

C. Replacing Keymat Assembly

1. Replace with new Keymat Assembly Kit by reversing the steps 1- 6 above.

WARNING

MAKE CERTAIN WHEN INSTALLING CONTROL BOARD ASSEMBLY TO KEYMAT PC BOARD PINS FROM THE CONTROL BOARD ALIGN WITH THE CONNECTOR ON THE KEYMAT PC BOARD.

NOTE:

- Do not over tighten the screws. Over tightening will damage the threads of the brass inserts.
2. Re-assemble Therapy System referring to the appropriate sections of this manual for proper instructions.

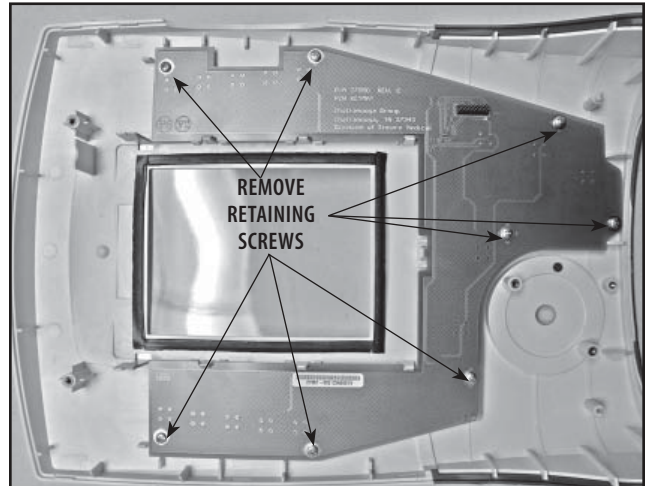

FIGURE 6.28

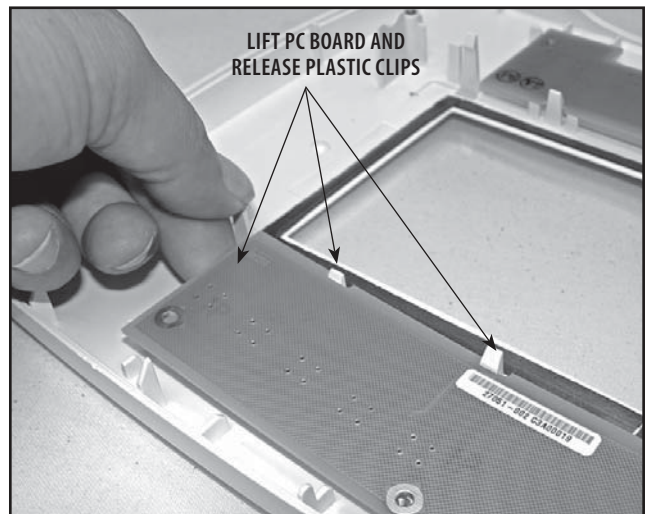

FIGURE 6.29

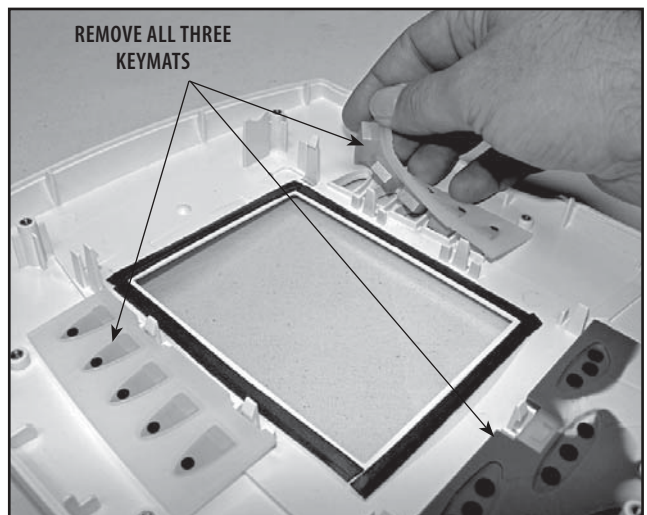

FIGURE 6.30

6- REMOVAL/REPLACEMENT

6.7 THERAPY SYSTEM- CONNECTOR BOARD

WARNING

DISCONNECT THE SYSTEM FROM THE POWER SOURCE (OUTLET OR REMOVE BATTERY MODULE IF INSTALLED) BEFORE ATTEMPTING ANY MAINTENANCE, INSTALLATION, REMOVAL, OR REPLACEMENT PROCEDURES TO PREVENT ELECTRICAL SHOCK AND POSSIBLE DAMAGE TO SYSTEM.

A. Tools and Equipment Required

- #1 Phillips Screwdriver

B. Connector Board Removal

1. Separate Top from Bottom. Refer to 6.3, part B.
2. Remove Connector Infill and Lanyard. Lay aside. See Figure 6.31.
3. Carefully pull Connector Board out toward front of System. See Figure 6.32.

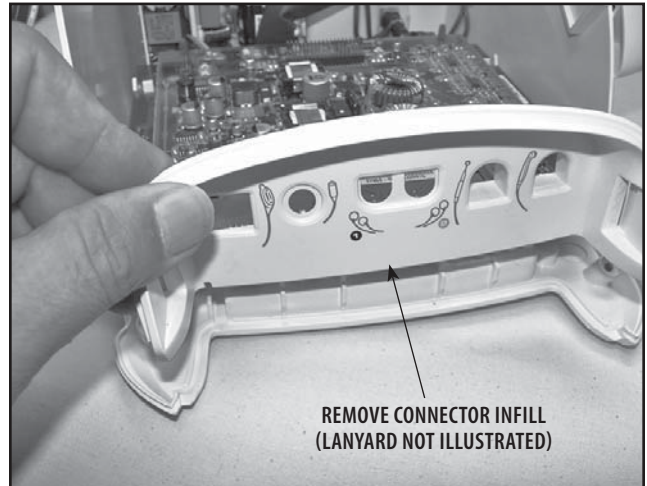

FIGURE 6.31

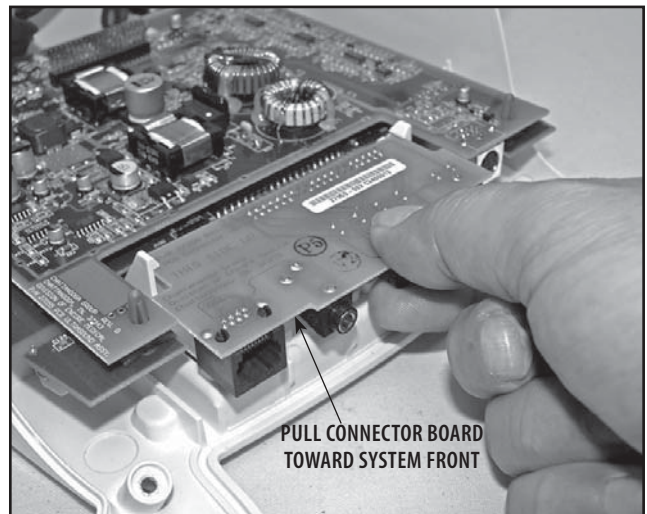

FIGURE 6.32

C. Replacing Connector Board

1. Replace new Connector Board, part number 27059 in reverse order of **steps 1-3** above. Make Certain the words "THIS SIDE UP" on Connector Board are facing up. Make certain Connector Board is completely seated in Stim Board Connector. See Figure 6.33.
2. Re-install the Connector Infill and Lanyard. Refer to Figure 6.31.
3. Re-assemble Therapy System. Refer to 6.3, part C for proper instructions.

NOTE:

Do not over tighten the screws. Over tightening will damage the threads of the brass inserts.

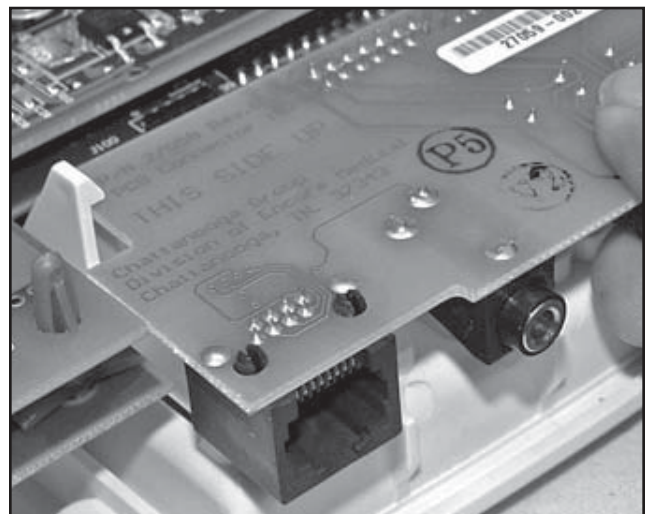

FIGURE 6.33

6- REMOVAL/REPLACEMENT

6.8 THERAPY SYSTEM- ULTRASOUND BOARD (COMBINATION SYSTEMS ONLY)

WARNING

DISCONNECT THE SYSTEM FROM THE POWER SOURCE (OUTLET OR REMOVE BATTERY MODULE IF INSTALLED) BEFORE ATTEMPTING ANY MAINTENANCE, INSTALLATION, REMOVAL, OR REPLACEMENT PROCEDURES TO PREVENT ELECTRICAL SHOCK AND POSSIBLE DAMAGE TO SYSTEM.

A. Tools and Equipment Required

1. #1 Phillips Screwdriver
2. Needle Nose Pliers

B. Ultrasound Board Removal

1. Separate Top from Bottom. Refer to 6.3, part B.
2. Remove Connector Board. Refer to 6.7.

NOTE:

It may be necessary to have help in removing the Ultrasound Board due to the tight fit of the Header Connector between the Ultrasound Board and the Stim Board.

3. Gently and firmly pull up the back corners of the Ultrasound Board and use the Needle Nose Pliers to release the board from the Blue Stand offs in each corner of the Ultrasound Board. See Figure 6.34.
4. Firmly pull each side of the Ultrasound board up until the board is almost off of the Header Connector and is clear of the Stand Off Barbs. See Figure 6.35.
5. Use the Needle Nose Pliers to release the Ultrasound Board from the front Stand Offs. See inset in Figure 6.34.

C. Replacing Ultrasound Board

1. Replace new Ultrasound Board, part number 27055 in reverse order of steps 1-5 above.

WARNING

MAKE CERTAIN THE STIM BOARD HEADER PINS ARE PROPERLY ALIGNED WITH THE ULTRASOUND BOARD WHEN INSTALLING ULTRASOUND BOARD. SEE FIGURE 6.36.

FAILURE TO PROPERLY ALIGN HEADER PINS WILL RESULT IN SEVERE DAMAGE TO THE SYSTEM.

2. Re-assemble Therapy System. Refer to 6.7 and 6.3, part C for proper instructions.

NOTE:

Do not over tighten the screws. Over tightening will damage the threads of the brass inserts.

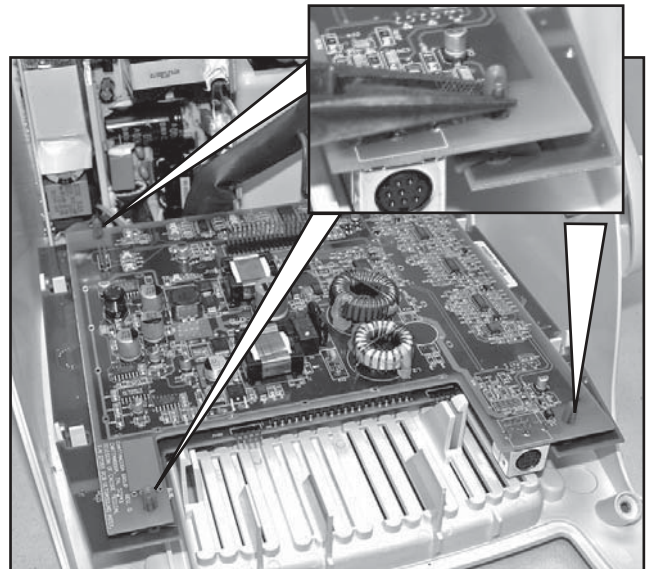

FIGURE 6.34

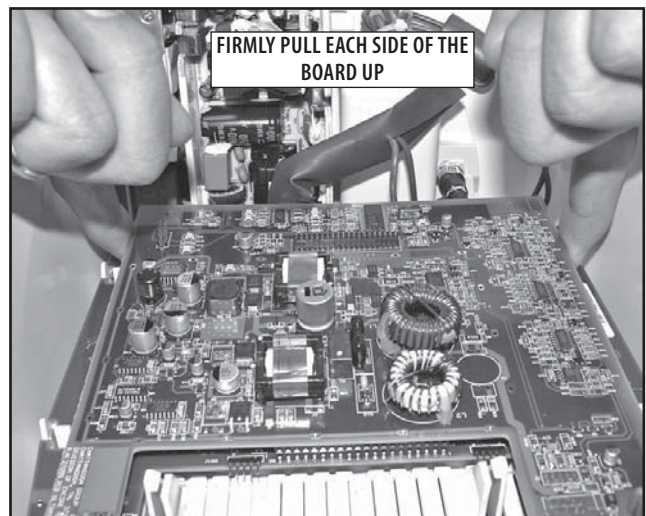

FIGURE 6.35

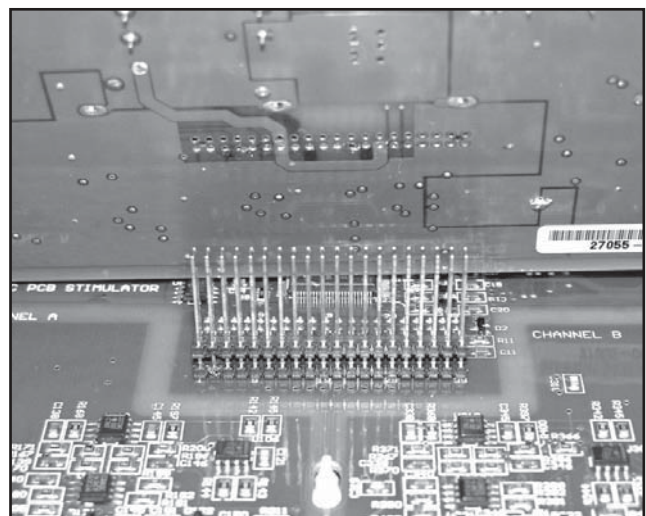

FIGURE 6.36

6- REMOVAL/REPLACEMENT

6.9 THERAPY SYSTEM- STIM BOARD (CHANNELS 1/2)

WARNING

DISCONNECT THE SYSTEM FROM THE POWER SOURCE (OUTLET OR REMOVE BATTERY MODULE IF INSTALLED) BEFORE ATTEMPTING ANY MAINTENANCE, INSTALLATION, REMOVAL, OR REPLACEMENT PROCEDURES TO PREVENT ELECTRICAL SHOCK AND POSSIBLE DAMAGE TO SYSTEM.

A. Tools and Equipment Required

1. #1 Phillips Screwdriver
2. Needle Nose Pliers
3. Flat Blade Screwdriver

B. Stim Board (Channels 1/2) Removal

1. Remove Channel 3/4 Electrotherapy, NiMH Battery, or Laser Module, if installed. Refer to 6.1 for instructions.
2. Remove sEMG Module if equipped. Refer to 6.2, part C.
3. Separate Top from Bottom. Refer to 6.3, part B.
4. Remove Connector Board. Refer to 6.7, part B.
5. Remove Ultrasound Board on Combination Systems. Refer to 6.10.
6. Lay Therapy System on one side and use the Flat Blade Screwdriver to remove the 1/4 Turn Fastener retaining the Stim Board in position. See Figure 6.37.
7. Remove System to Module Ribbon Cable from System. See Figure 6.37A.
8. Gently pull up on each corner and release the plastic retaining tabs holding the Stim Board in position. See Figure 6.38.

C. Replacing Stim Board

1. Replace new Stim Board, part number 27056 in reverse order of steps 1-8 above. Make certain Jumpers are properly set on Stim Board. See Figure 6.38A

NOTE:

Position Ribbon Cable so the Blue Strip is positioned as shown in Figure 6.37A. Press on Stim Board while seating Ribbon Cable to the system. On Combination Systems, install the Ribbon Cable and 1/4 turn fastener before installing the Ultrasound Board.

2. Re-assemble Therapy System. Refer to 6.8 part C, 6.7 and 6.3, part C for proper instructions.

NOTE:

Do not over tighten the screws. Over tightening will damage the threads of the brass inserts.

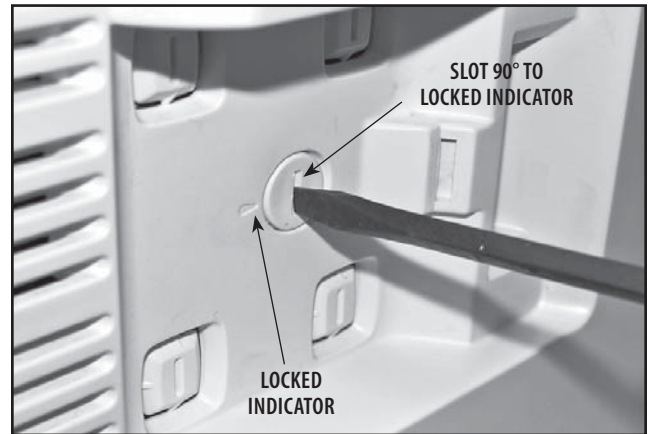

FIGURE 6.37

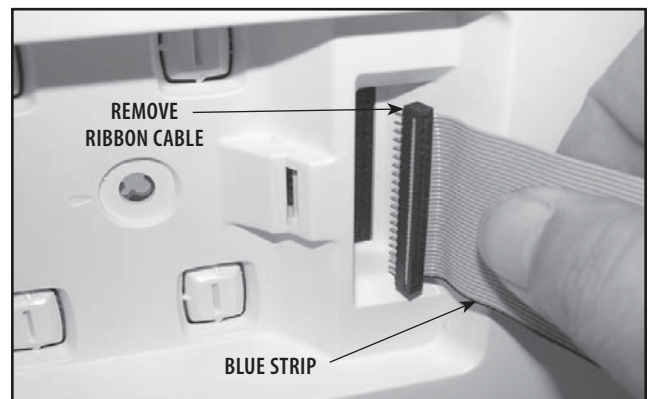

FIGURE 6.37 A

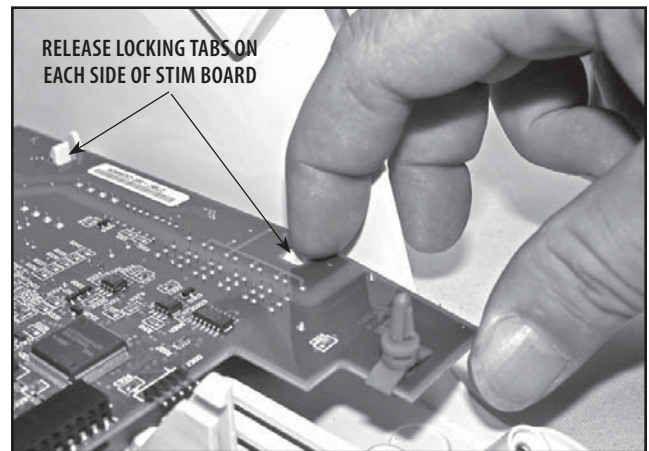

FIGURE 6.38

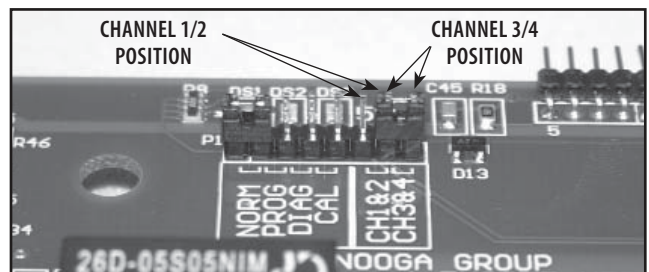

FIGURE 6.48A

6- REMOVAL/REPLACEMENT

6.10 THERAPY SYSTEM- POWER SUPPLIES

NOTE:

The Vectra Genisys, Intelect Legend XT and Intelect Vet Therapy Systems incorporate two different Power Supply configurations:

Combination Therapy System- Two Power Supplies, one 75 Watt for Ultrasound Power and one 100 Watt to power the rest of the system.

Electrotherapy System- One 100 Watt Power Supply.

⚠ WARNING

DISCONNECT THE SYSTEM FROM THE POWER SOURCE (OUTLET OR REMOVE BATTERY MODULE IF INSTALLED) BEFORE ATTEMPTING ANY MAINTENANCE, INSTALLATION, REMOVAL, OR REPLACEMENT PROCEDURES TO PREVENT ELECTRICAL SHOCK AND POSSIBLE DAMAGE TO SYSTEM.

A. Tools and Equipment Required

1. #1 Phillips Screwdriver
2. Insulated Needle Nose Pliers
3. Flat Blade Screwdriver
4. Digital Multimeter

B. Power Supply Removal

1. Separate Top from Bottom. Refer to 6.3, part B.
2. Remove Connector Board. Refer to 6.7, part B.
3. Remove Ultrasound Board on Combination Systems. Refer to 6.8, part B.
4. Remove Stim Board. Refer to 6.9, part B.
5. Using the # 1 Phillips Screwdriver, remove the two screws securing the Power Supply Assembly to the System Housing. See Figure 6.39.



FIGURE 6.39

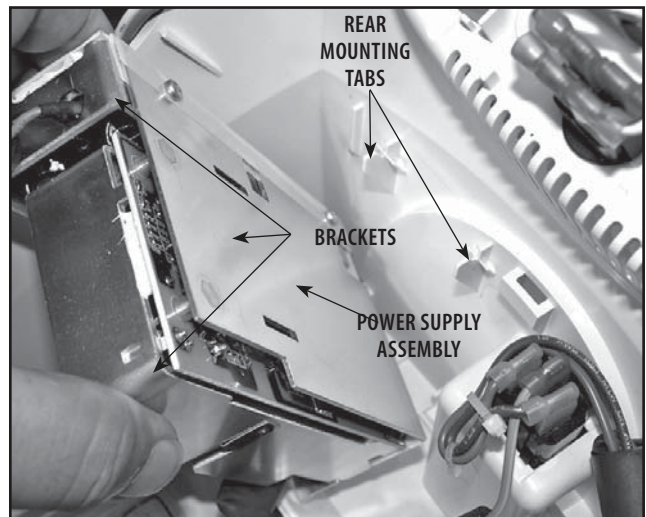

FIGURE 6.40

⚠ DANGER

⚡ POWER SUPPLIES RETAIN HIGH VOLTAGE! WHEN REMOVING FROM SYSTEM, HANDLE POWER SUPPLIES BY MOUNTING BRACKETS ONLY.

6. Lift Power Supply Assembly up to remove from rear mounting tabs. See Figure 6.40.
7. Using the Digital Multimeter, discharge the Power Supplies as follows:
 - a) 100 Watt Power Supply- Discharge Capacitor C4. See Figure 6.41.
 - b) 75 Watt Power Supply (Combo Systems Only)- Discharge Capacitor on back of Power Supply PC Board. Pins are on either side of "R8A" on PC Board. See Figure 6.41.

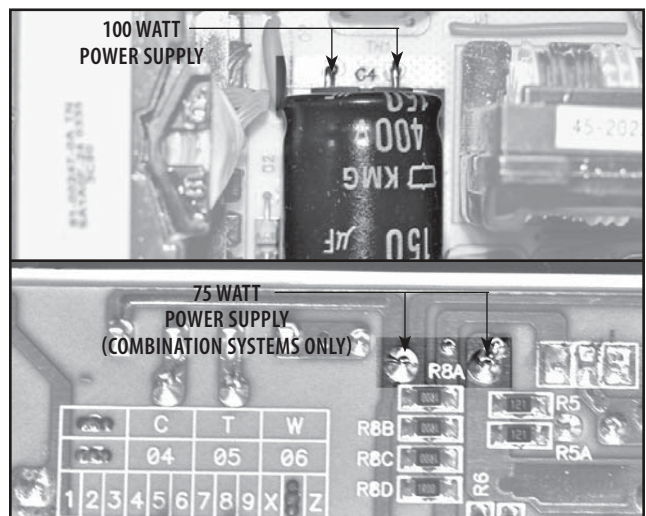

FIGURE 6.41

6.10 THERAPY SYSTEM- POWER SUPPLIES (CONTINUED)

WARNING

DISCONNECT THE SYSTEM FROM THE POWER SOURCE (OUTLET OR REMOVE BATTERY MODULE IF INSTALLED) BEFORE ATTEMPTING ANY MAINTENANCE, INSTALLATION, REMOVAL, OR REPLACEMENT PROCEDURES TO PREVENT ELECTRICAL SHOCK AND POSSIBLE DAMAGE TO SYSTEM.

8. Using Insulated Needle Nose Pliers, disconnect the Mains Connector Wiring Harness from the Power Supply Assembly. **See Figure 6.45.**
9. Remove 100 Watt Power Supply from Mounting Bracket by removing the two retaining screws from the inside top of the Power Supply. **See Figure 6.42.**
NOTE:
Steps 10 and 11 below applies only to Combination Systems.
10. Remove 75 Watt Power Supply from Mounting Bracket by removing the two mounting screws on the back of Mounting Bracket securing the 75 Watt Power Supply. **See inset at Figure 6.43.**
11. Using Insulated Needle Nose Pliers, remove the 100 Watt Power Supply Harness from the 75 Watt Power Supply. **See Figure 6.44.**

C. Replacing Power Supplies

1. Replace new Power Supplies in reverse order of preceding steps, using part numbers:
 - a) 27048 100 Watt Power Supply
 - b) 27049 75 Watt Power Supply (Combo System Only)
2. Re-assemble Therapy System. **Refer to 6.9, part C, 6.8, part C, 6.7, part C, and 6.3, part C** for proper instructions.

NOTE:

Do not over tighten the screws. Over tightening will damage the threads of the brass inserts.

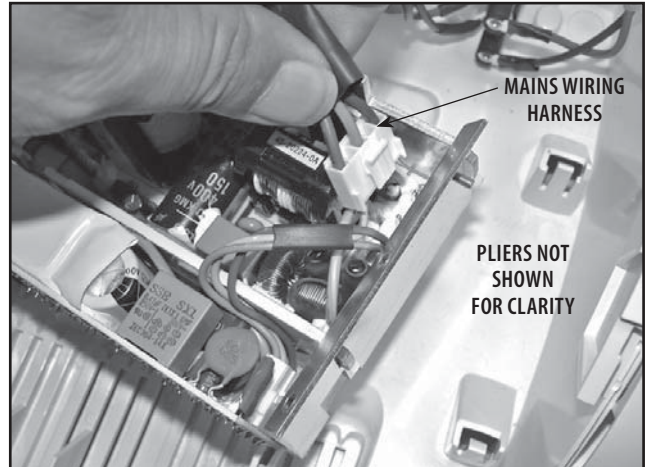

FIGURE 6.42

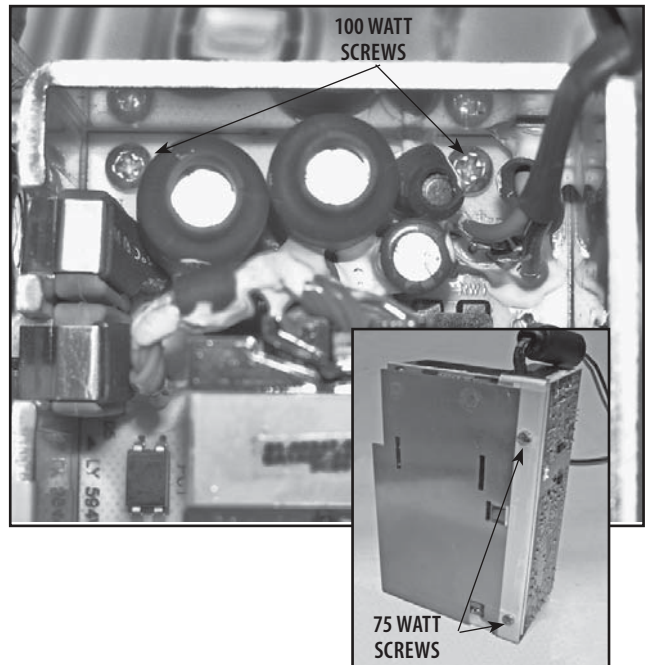

FIGURE 6.43

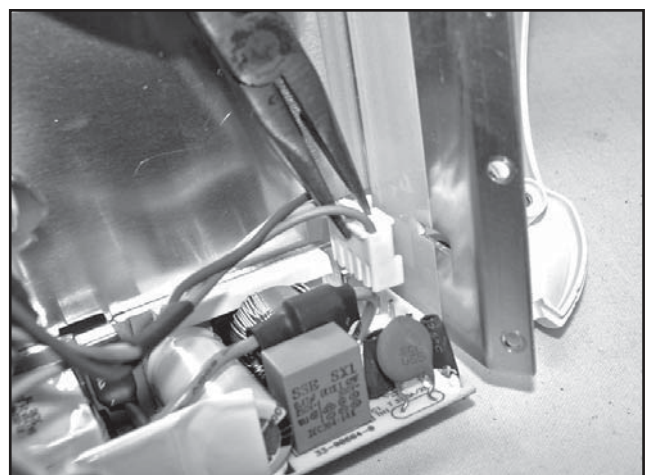

FIGURE 6.44

6.11 CHANNEL 3/4 ELECTROTHERAPY MODULE CONNECTOR BOARD

WARNING

DISCONNECT THE SYSTEM FROM THE POWER SOURCE (OUTLET OR REMOVE BATTERY MODULE IF INSTALLED) BEFORE ATTEMPTING ANY MAINTENANCE, INSTALLATION, REMOVAL, OR REPLACEMENT PROCEDURES TO PREVENT ELECTRICAL SHOCK AND POSSIBLE DAMAGE TO SYSTEM.

A. Tools and Equipment Required

1. #1 Phillips Screwdriver
2. Flat Blade Screwdriver

B. Module Connector Board Removal

1. Remove Module from Therapy System. Refer to 6.2, part C.
2. Release the Module Top Retaining Tabs with the Flat Blade Screwdriver. See Figure 6.45. Remove Top.
3. Remove Module Connector Infill. See Figure 6.46.
4. Carefully pull Connector Board out toward front of Module. See Figure 6.47.

C. Replacing Connector Board

1. Replace new Connector Board, part number 27059 in reverse order of steps 1-4 above. Make Certain the words "THIS SIDE UP" on Connector Board are facing up. Make certain Connector Board is completely seated in Stim Board Connector. See Figure 6.47.
2. Re-install the Connector Infill and Lanyard. Refer to Figure 6.46.
3. Re-assemble Therapy System referring to the appropriate sections of this manual for proper instructions.

NOTE:

Do not over tighten the screws. Over tightening will damage the threads of the brass inserts.



FIGURE 6.45

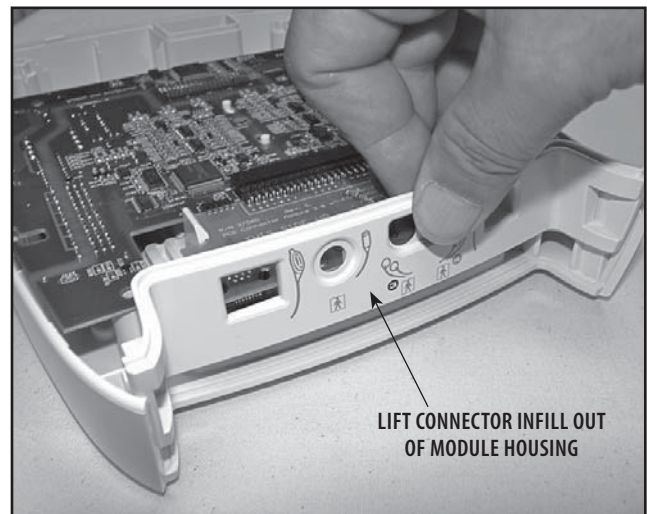

FIGURE 6.46

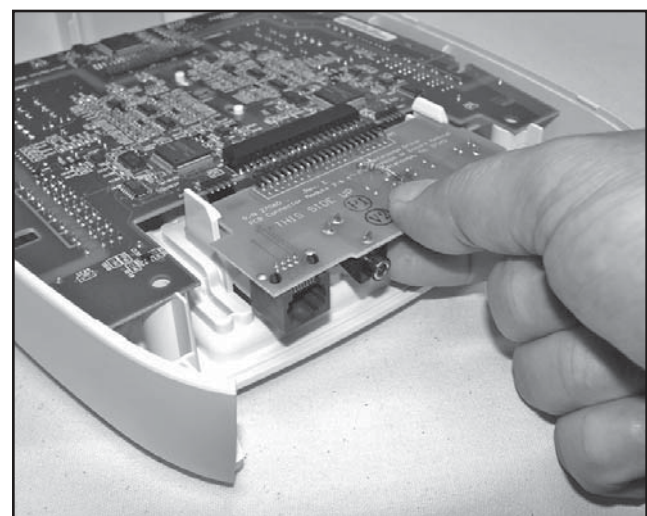

FIGURE 6.47

6.12 CHANNEL 3/4 ELECTROTHERAPY MODULE STIM BOARD

WARNING

DISCONNECT THE SYSTEM FROM THE POWER SOURCE (OUTLET OR REMOVE BATTERY MODULE IF INSTALLED) BEFORE ATTEMPTING ANY MAINTENANCE, INSTALLATION, REMOVAL, OR REPLACEMENT PROCEDURES TO PREVENT ELECTRICAL SHOCK AND POSSIBLE DAMAGE TO SYSTEM.

A. Tools and Equipment Required

1. #1 Phillips Screwdriver
2. Flat Blade Screwdriver

B. Channel 3/4 Electrotherapy Module Stim Board Removal

1. Remove Module from Therapy System. Refer to 6.2, part C.
2. Remove Module Connector Infill. Refer to Figure 6.13.
3. Remove Module Connector Board. See Figure 6.48.
4. Lift Channel 3/4 Stim Board from Module Housing. See Figure 6.48A.

C. Replacing Channel 3/4 Electrotherapy Module Stim Board

1. Replace new Stim Board, part number 27056 in reverse order of **steps 1-4** above.
2. Re-assemble Module and Therapy System referring to the appropriate sections of this manual for proper instructions.

NOTE:

Do not over tighten the screws. Over tightening will damage the threads of the brass inserts.

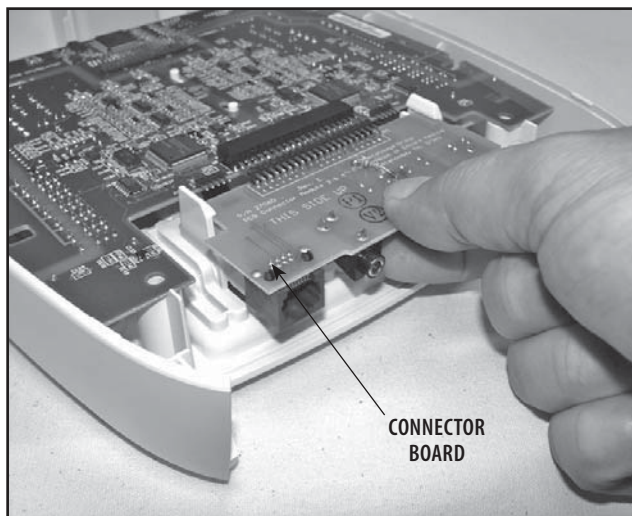

FIGURE 6.48

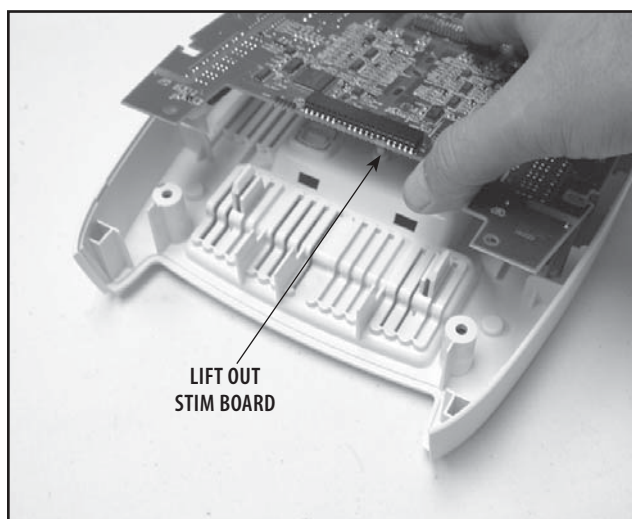

FIGURE 6.48A

6.13 MOUNTING AND DISMOUNTING THERAPY SYSTEM AND THERAPY SYSTEM CART

WARNING

DISCONNECT THE SYSTEM FROM THE POWER SOURCE (OUTLET OR REMOVE BATTERY MODULE IF INSTALLED) BEFORE ATTEMPTING ANY MAINTENANCE, INSTALLATION, REMOVAL, OR REPLACEMENT PROCEDURES TO PREVENT ELECTRICAL SHOCK AND POSSIBLE DAMAGE TO SYSTEM.

A. Mounting Therapy System to Therapy System Cart

1. Remove all the Storage Bins from both sides of the Therapy System Cart by pulling each bin out and up. **See Figure 6.49.**
2. Allow approximately 11.5 cm (4.5") of the power cord extending through the top of the cart for connecting to system. If the system is equipped with an optional NiMH Battery, Laser, or Channel 3/4 Electrotherapy Module, it will be necessary to allow 16.5 cm (6.5") of the Power Cord extending through the top of the Therapy System Cart. **See Figure 6.50.**
3. Secure the System to the cart with the four socket head screws in the Therapy System Cart Top. **See Figure 6.51.**

NOTE:

Secure the System to the cart by tightening the screws by hand only. Do not use a wrench to tighten the screws. Overtightening may cause damage to the System or Module housing.

4. Plug Power Cord into the System Mains Disconnect and reinstall the Rear Access Panel. Install all lead wires and cables to the System.
5. Install Storage Bins into Therapy System Cart. Start with bottom Storage Bin first.

B. Dismounting Therapy System from Therapy System Cart

1. To remove the System from the Therapy System Cart, repeat the Mounting System to Therapy System Cart instructions in reverse order.

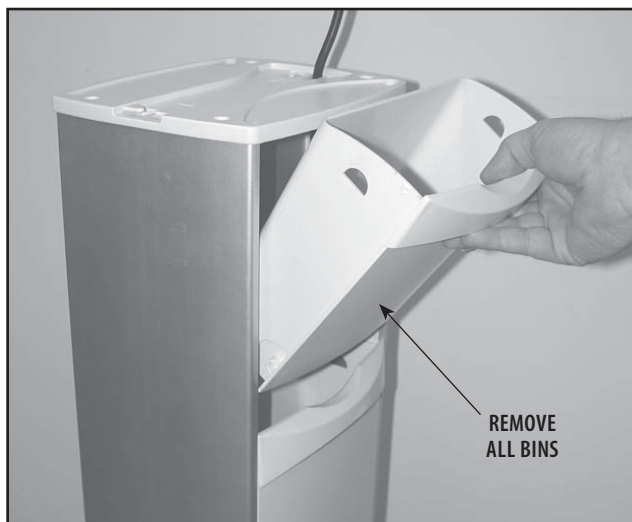

FIGURE 6.49

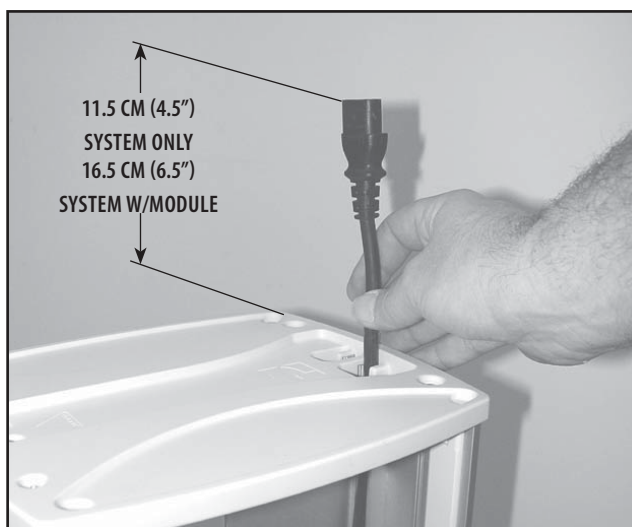

FIGURE 6.50

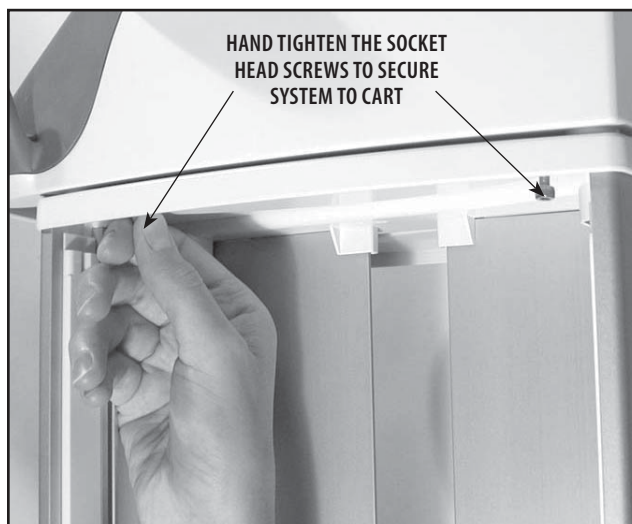

FIGURE 6.51

WARNING

DISCONNECT THE SYSTEM FROM THE POWER SOURCE (OUTLET OR REMOVE BATTERY MODULE IF INSTALLED) BEFORE ATTEMPTING ANY MAINTENANCE, INSTALLATION, REMOVAL, OR REPLACEMENT PROCEDURES TO PREVENT ELECTRICAL SHOCK AND POSSIBLE DAMAGE TO SYSTEM.

7.1 CLEANING THE SYSTEM

A. Cleaning the Therapy System

With the system disconnected from the power source, clean the system with a clean, lint free cloth moistened with water and mild antibacterial soap. If a more sterile cleaning is needed, use a cloth moistened with an antimicrobial cleaner.

Do not submerge the system in liquids. Should the unit accidentally become submerged, contact the dealer or Chattanooga Group Service Department immediately. Do not attempt to use a system that has been wet inside until inspected and tested by a Service Technician certified by Chattanooga Group.

Do not allow liquids to enter the ventilation holes in the optional modules. This could permanently damage the modules.

B. Lens Cleaning

1. Therapy System Screen Lens

Clean the Therapy System Lens with the NOVUS® Plastic Polishing System. NOVUS can be purchased by going to novuspolish.com on the internet. Follow the instructions as given by NOVUS on their product.

Do Not Use alcohol or chlorine based solvents as this may damage the lens.

2. Laser Applicator Lenses

Use only NOVUS #1 to clean the Laser Applicator Lenses. The Lens associated with each Laser Applicator has certain optical qualities that are critical to the proper operation of the Laser Applicator. Do not use NOVUS #2 OR #3 on the Laser Applicator Lenses. If the Lens is scratched it must be replaced by the factory.

The Laser applicators are not designed to prevent the ingress of liquids. Do not submerge the Laser Applicator in any liquid.

7.2 CALIBRATION REQUIREMENTS

A. Ultrasound Applicators:

Annual factory calibration is required for all Ultrasound Applicators. Only the Applicators should be sent to the factory for this procedure.

B. Laser Applicators

All Laser Applicators require annual calibration. All Laser Applicators must be sent to the factory for annual calibration.

7.3 FIELD SERVICE

A. All field service procedures as described in this Service Manual for the Vectra Genisys, Intelect Legend XT and Intelect Vet must be performed by a Service Technician certified by Chattanooga Group.

B. Any attempted outside the scope of this Service Manual is the sole responsibility and liability of the Field Technician performing such procedures.

C. All repairs to the Laser Module and Laser Applicators must be performed at the factory. There are no field serviceable components for the Laser Module or Laser Applicators.

7.4 FACTORY SERVICE

When the Vectra Genisys, Intelect Legend XT and Intelect Vet Therapy Systems requires factory service, contact the dealer or Chattanooga Group Service Department.

NOTE: These units were calibrated during the manufacturing process and are ready to be placed into service upon delivery.

8.1 GENERAL

A. Tools and Equipment Required

1. Vectra Genisys, Intelect Legend XT and the Intelect Vet Combination Therapy System and all Vectra Genisys, Intelect Legend XT and the Intelect Vet Ultrasound Applicators associated with the System being serviced.
2. Ohmic Instruments UPM DT 10 or DT 100 Ultrasound Power Meter, set to "watts".
3. Degassed Water. **Refer to page 37** for Degassed Water Recipes.

WARNING

USE ONLY DEGASSED WATER IN POWER METER FOR CALIBRATING ULTRASOUND APPLICATORS. USE OF OTHER TYPES OF WATER WILL CAUSE FALSE READINGS AND BAD TEST RESULTS.

SEE PAGE 37 FOR DEGASSED WATER RECIPES.

USE OF OTHER BRANDS OR TYPES OF TOOLS, EQUIPMENT, FIXTURES, MATERIALS, AND SUPPLIES OTHER THAN THOSE SPECIFICALLY LISTED IN "A. Tools and Equipment Required" ABOVE WILL GIVE BAD TEST AND CALIBRATION RESULTS.

IF PROPER EQUIPMENT IS NOT AVAILABLE OR CAN NOT BE OBTAINED, SEND THE ULTRASOUND APPLICATORS TO THE FACTORY FOR CALIBRATION.

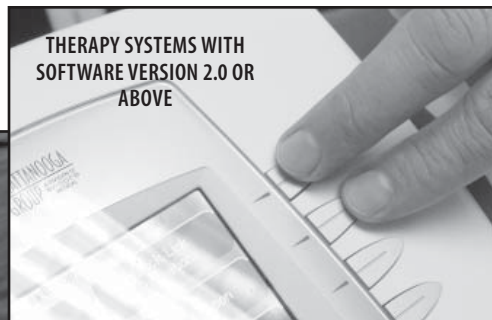

FIGURE 8.1

B. Ultrasound Applicator Calibration Procedures

1. Enter the Technical Service Screen of the Therapy System by pressing the Stop, Pause, and Start Buttons simultaneously. **See Figure 8.1.**

NOTE:

To access the Technical Service Screen of Therapy Systems with Version 2.0 or above software, simultaneously press the two buttons located at the upper right of the screen. **See inset at Figure 8.1.**

2. Set up Power Meter per Ohmic User Manual. Position the Ultrasound Applicator in the Power Meter.
3. Press the Ultrasound Calibration Button. **See Figure 8.2.**
4. Press the Head Size Button until the size applicator being calibrated is displayed. **See Figure 8.3.**
5. Press the Start Button, **refer to Figure 8.3.** Follow the instructions displayed on the Therapy System.
6. Repeat this procedure for each Ultrasound Applicator associated with the Therapy

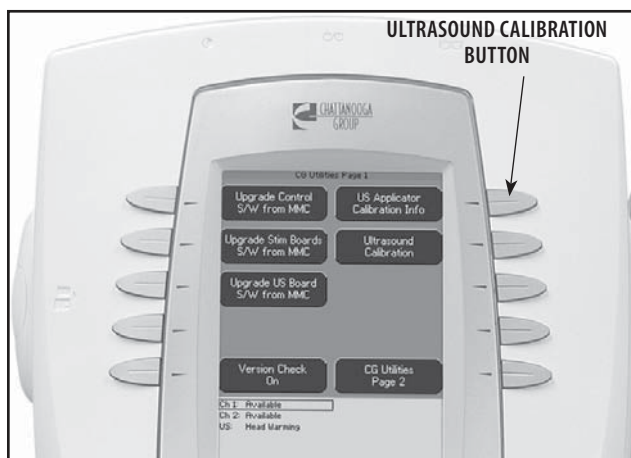

FIGURE 8.2

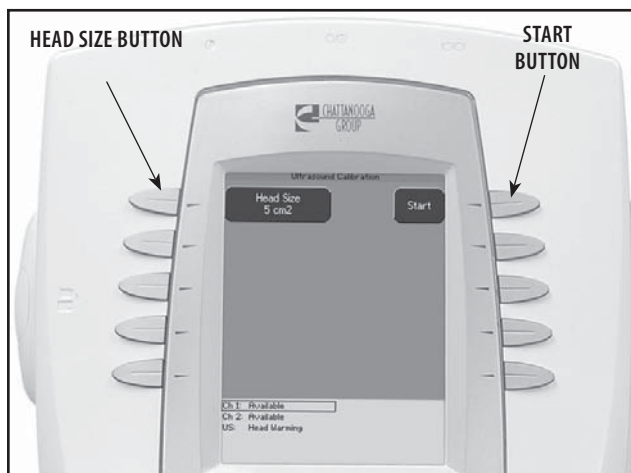
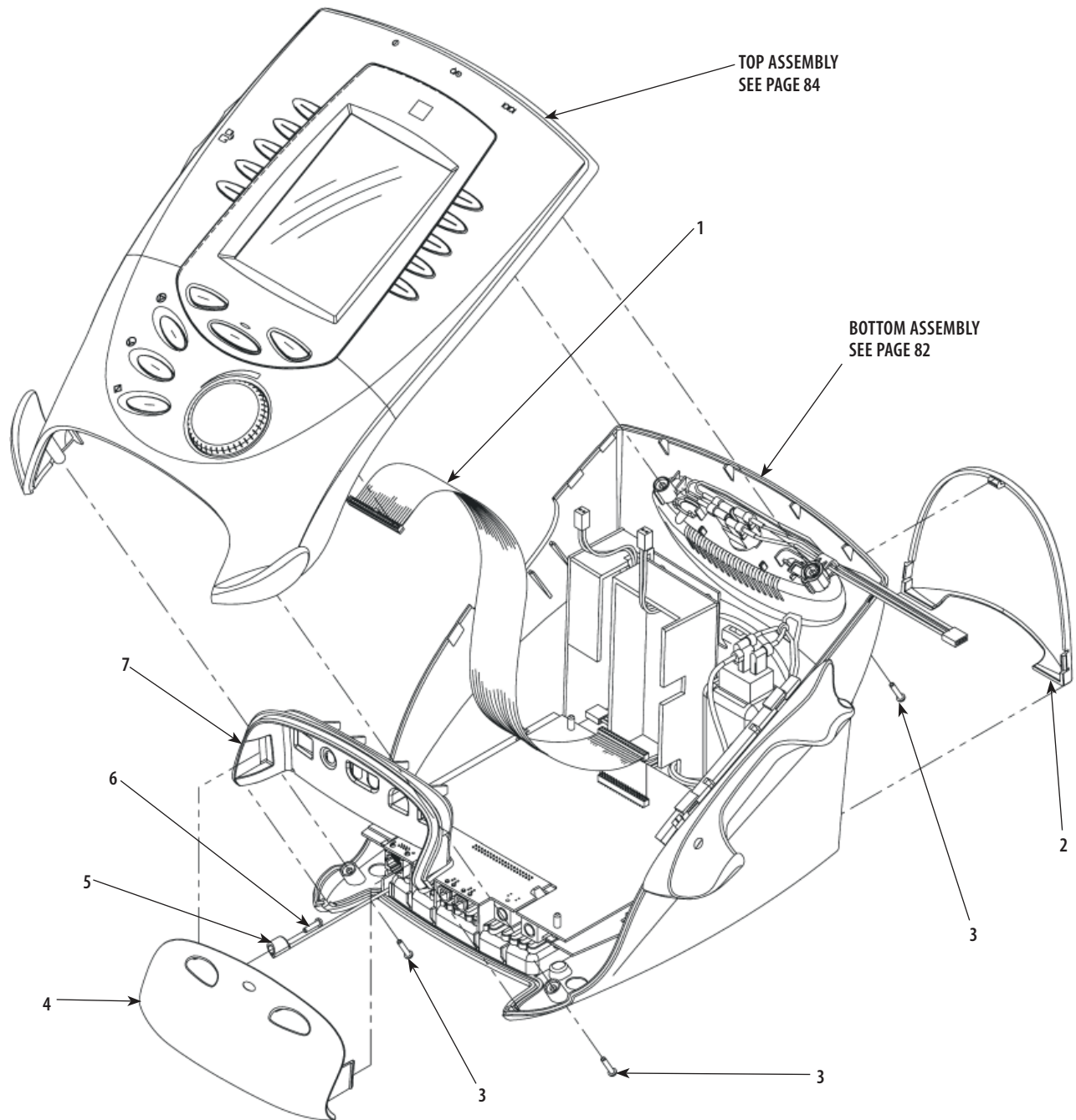

FIGURE 8.3

TOP TO BOTTOM ASSEMBLY



ITEM NUMBER	PART NUMBER	DESCRIPTION	QTY REQ'D
1	27159	Bottom Assembly to Top Assembly Ribbon Cable	1
2	27306	Rear Access Panel	1
3	27138	Screw, M3 x 16 mm	4
4	27029	Front Access Panel	1
5	27020	Lanyard	1
6	21188	Screw, #4-40 x .375in	1
7	27007	Front Infill	1

COMBINATION SYSTEM BASE ASSEMBLY

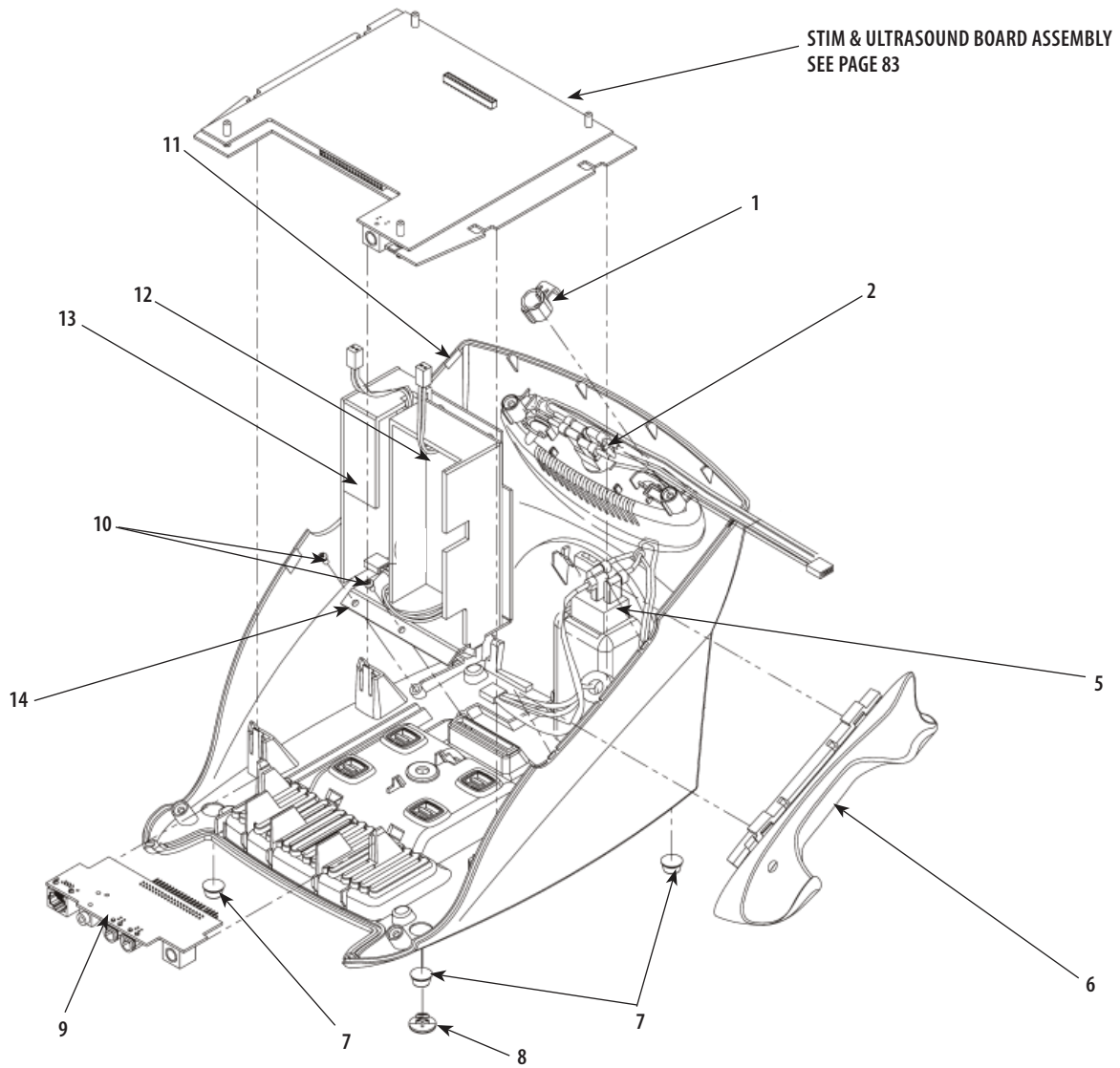

ITEM NUMBER	PART NUMBER	DESCRIPTION	QTY REQ'D
1	27022	Mains Harness Clip	1
2	27276	Main Power Switch	1
5	27277	Mains Power Input Connector	1
6	27010	Applicator Holder	1
7	27274	Feet	4
8	27436	Stim Board 1/4 Turn Pin	1
9	27059	Stim Connector Board	1
10	27142	Screws, M3 x 6mm	2
11	27006	Base Housing	1
12	27048	100 Watt Power Supply	1
13	27049	75 Watt Power Supply (Combination Systems Only)	1
14	27000	Power Supply Mounting Bracket	1

COMBINATION STIM & ULTRASOUND PC BOARD ASSEMBLY

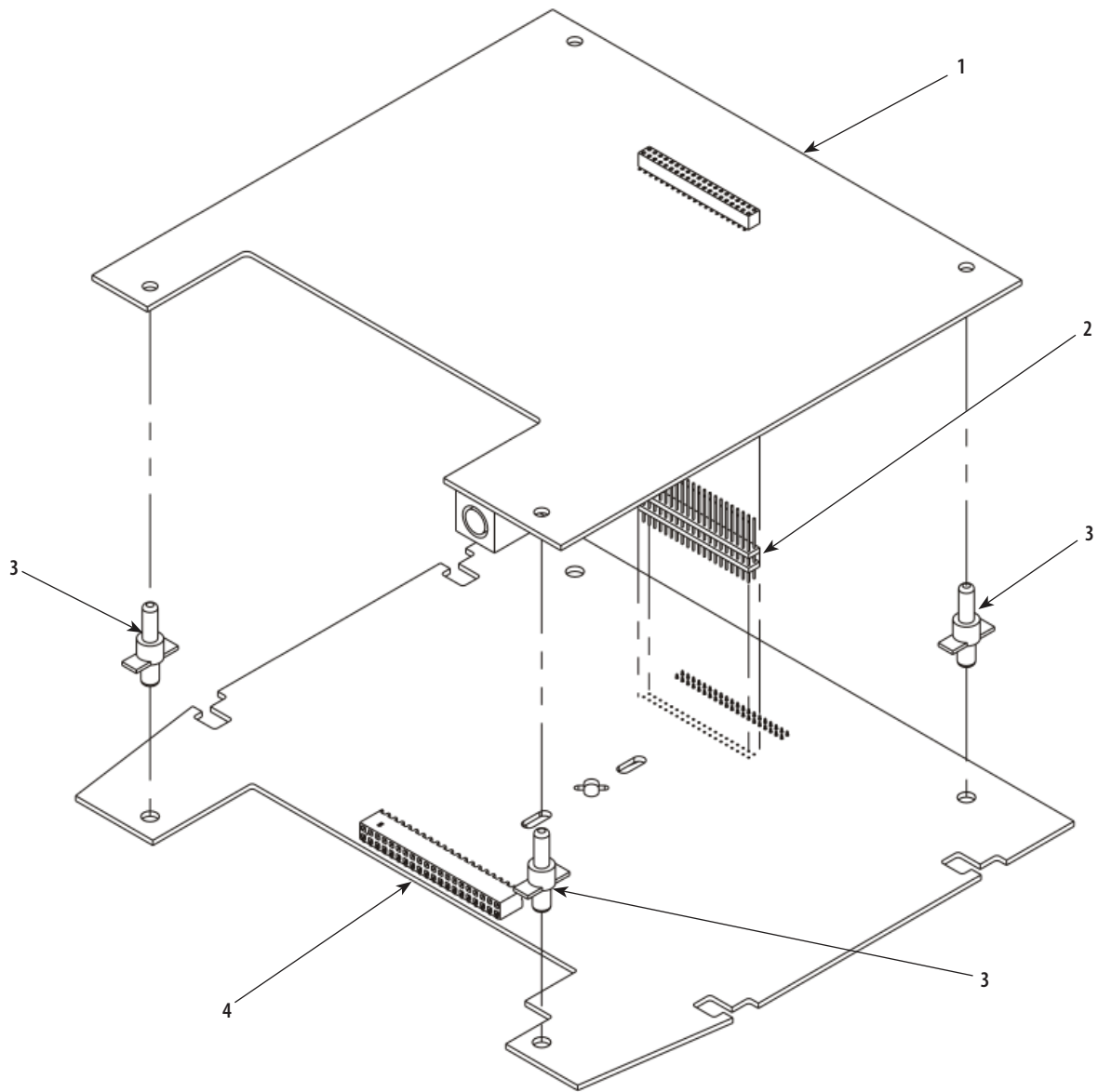

ITEM NUMBER	PART NUMBER	DESCRIPTION	QTY REQ'D
1	27055	Ultrasound PC Board	1
2	27161	Ultrasound to Stim Header	1
3	27160	PC Board Stand Off	4
4	27057	Stim PC Board	1

9- PARTS

TOP HOUSING ASSEMBLY

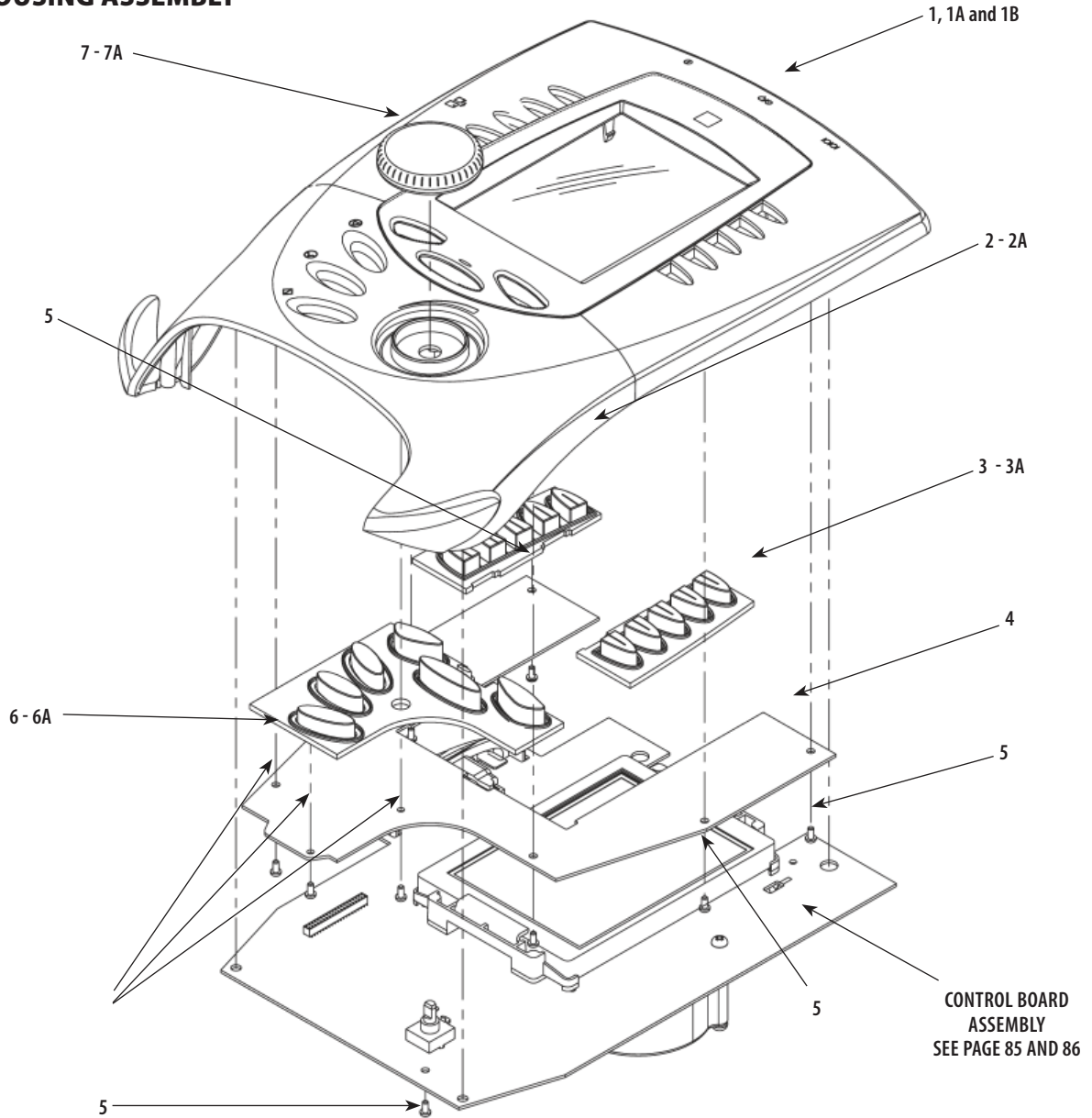

ITEM NUMBER	PART NUMBER	DESCRIPTION	QTY REQ'D
1	27107	Top Housing (Vectra Genisys)	1
1A	27237	Top Housing (Intelect Legend XT)	1
1B	29024	Top Housing (Intelect Vet)	1
2	27026	Left Keymat (Vectra Genisys)	1
2A	27235	Left Keymat (Intelect Legend XT)	1
3	27027	Right Keymat (Vectra Genisys)	1
3A	27236	Right Keymat (Intelect Legend XT)	1
4	27051	Keymat PC Board	1
5	27142	Screw, M3 x 6 mm	10
6	27028	Bottom Keymat (Vectra Genisys)	1
6A	27301	Bottom Keymat (Intelect Legend XT)	1
7	27305	Intensity Control Knob (Vectra Genisys)	1
7A	27238	Intensity Control Knob (Intelect Legend XT)	1

VECTRA GENISYS AND INTELECT VET CONTROL BOARD ASSEMBLY

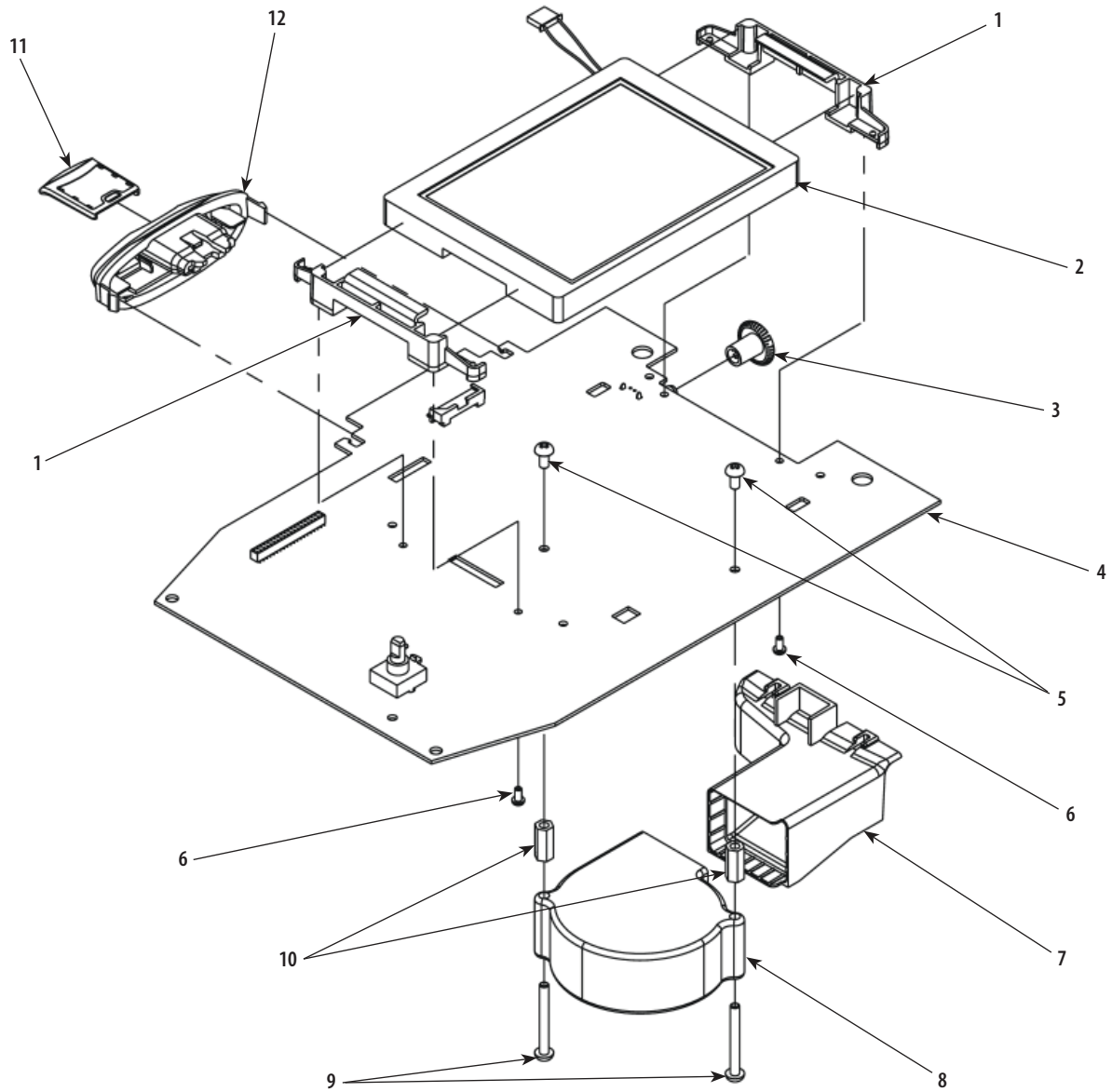

ITEM NUMBER	PART NUMBER	DESCRIPTION	QTY REQ'D
1	27093	Color Display Mounting Bracket/Spacer	2
2	27162	Color Display	1
3	27012	Contrast Knob (Not Functional)	1
4	27053	Color Control PC Board	1
5	27137	Screw, M4 x 8 mm	2
6	21188	Screw, PSM PT Type	4
7	27021	Air Exhaust Funnel	1
8	27158	Cooling Fan	1
9	27136	Screw, #4-40 x .375"	4
10	27144	Fan Mounting Stand Off, M4 x 16 mm	2
11	27024	MMC Card Top	1
12	27009	Patient Data Card and MMC Card System Port Housing	1

INTELECT LEGEND XT CONTROL BOARD ASSEMBLY

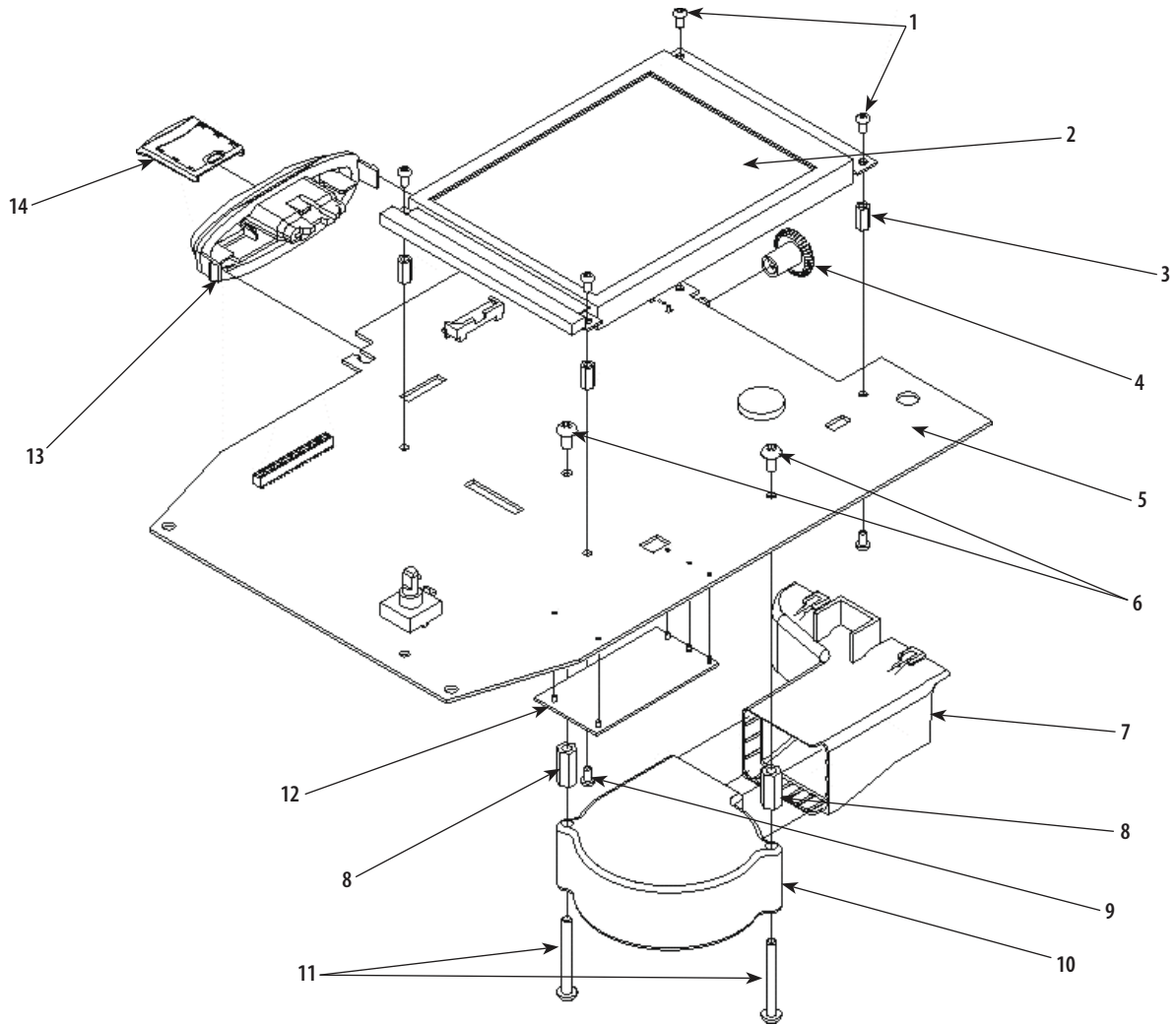

ITEM NUMBER	PART NUMBER	DESCRIPTION	QTY REQ'D
1	27512	Screw, M3 x 4 mm	4
2	27180	Monochromatic LCD	1
3	27145	Stand Off, M3 x 10 mm	4
4	27012	Contrast Knob (Functional)	1
5	27053	Control PCB	1
6	27137	Screw, M4 x 8 mm	2
7	27021	Air Exhaust Funnel	1
8	27144	Stand Off, M4 x 16 mm	2
9	27142	Screw, M3 x 6 mm	4
10	27158	Cooling Fan	1
11	27136	Screw, M4 x 35 mm	2
12	27756	Inverter	1
13	27009	Patient Data Card and MMC Card System Port Housing	1
14	27085	MMC Card Top	1

CHANNEL 3/4 ELECTROTHERAPY MODULE ASSEMBLY

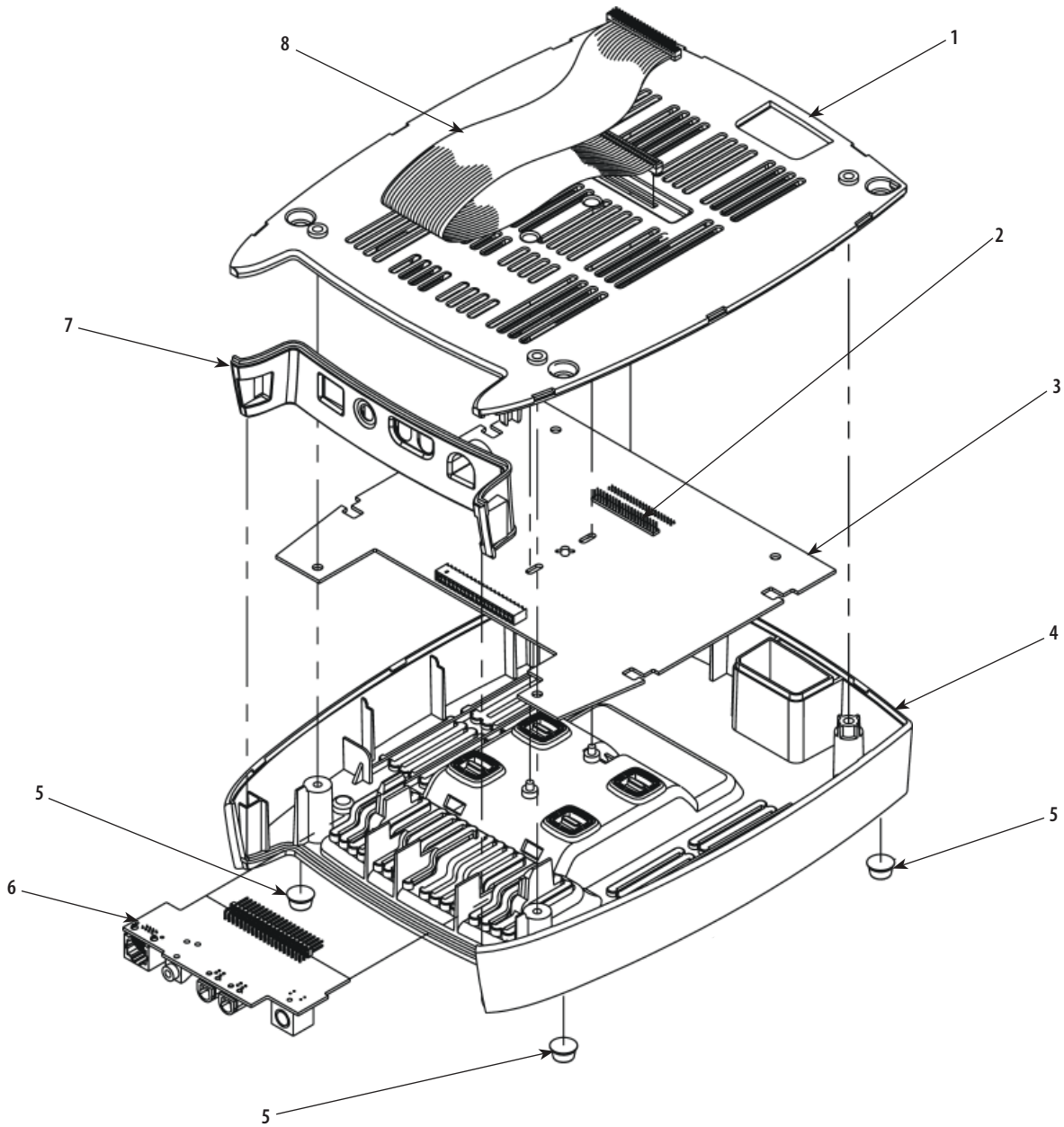

ITEM NUMBER	PART NUMBER	DESCRIPTION	QTY REQ'D
1	27015	Module Top	1
2	27353	Stim Board to Ribbon Cable Header	1
3	27057	Stim PC Board	1
4	27016	Module Bottom Housing	1
5	27150	Feet	4
6	27061	Channel 3/4 Stim Connector PC Board	1
7	27017	Connector Infill	1
8	27136	Module to Therapy System Ribbon Cable (Mounted onto Therapy System)	1

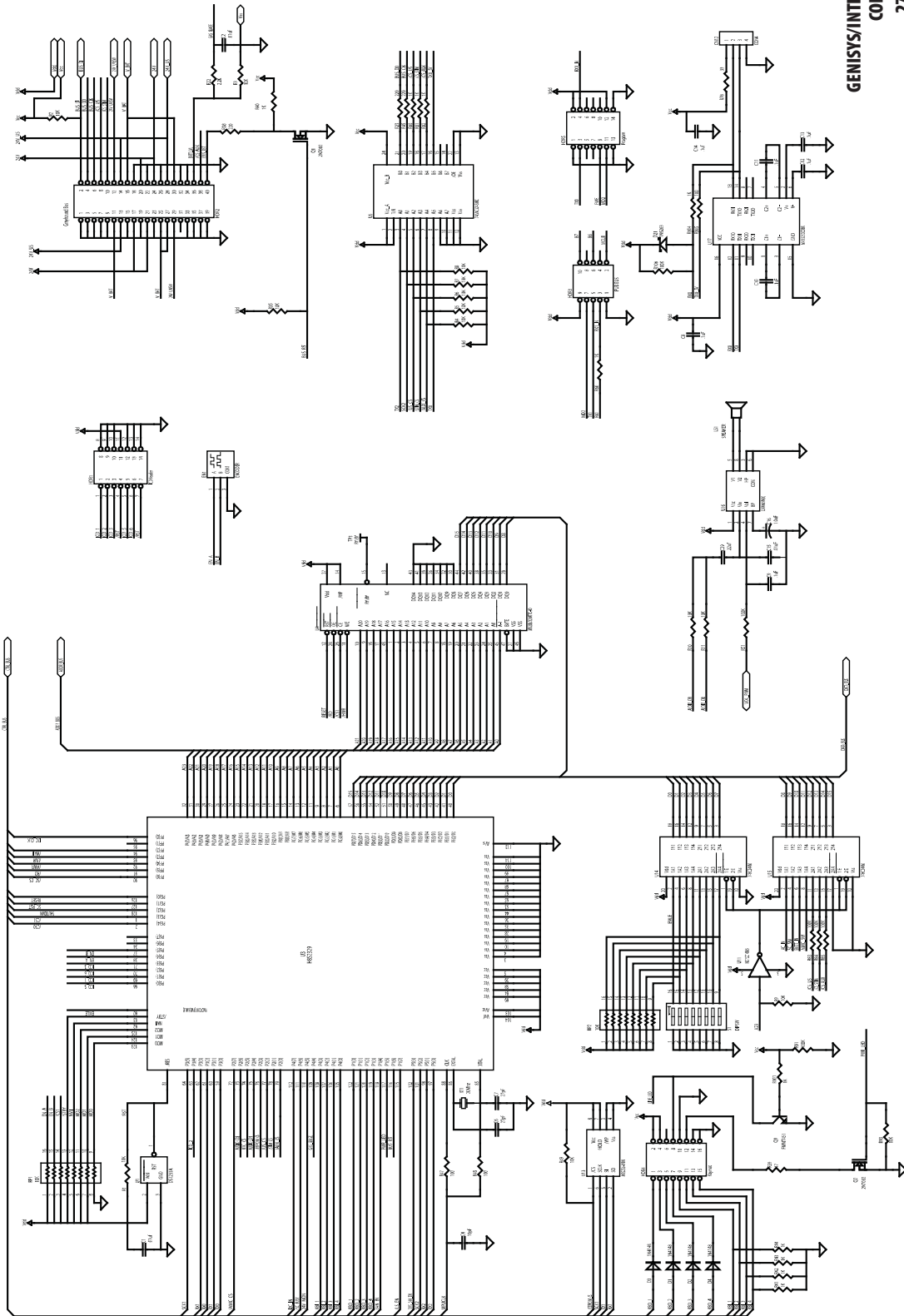

**GENISYS/INTELLECT THERAPY SYSTEM-
CONTROL BOARD
27053 Sheet 1**

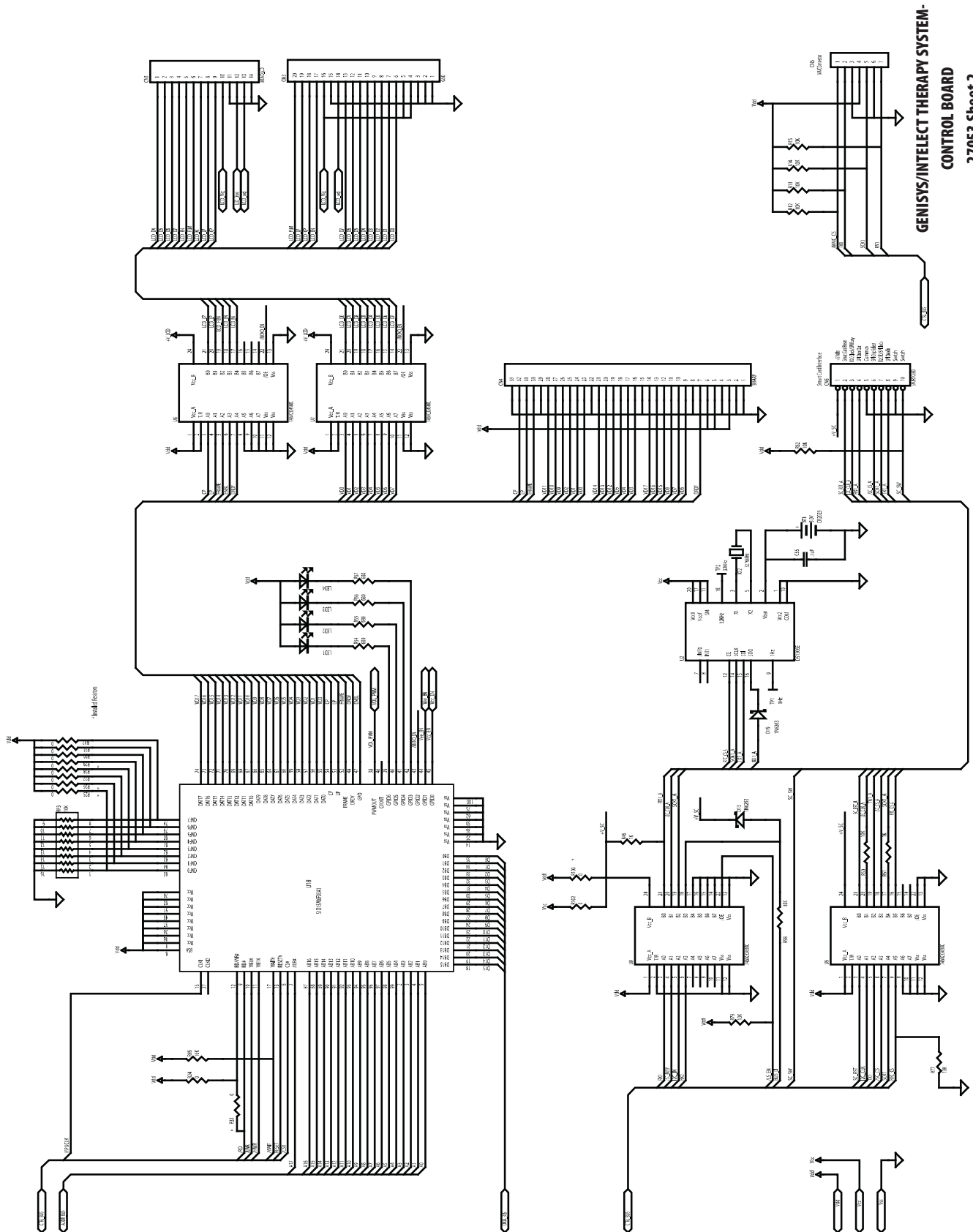

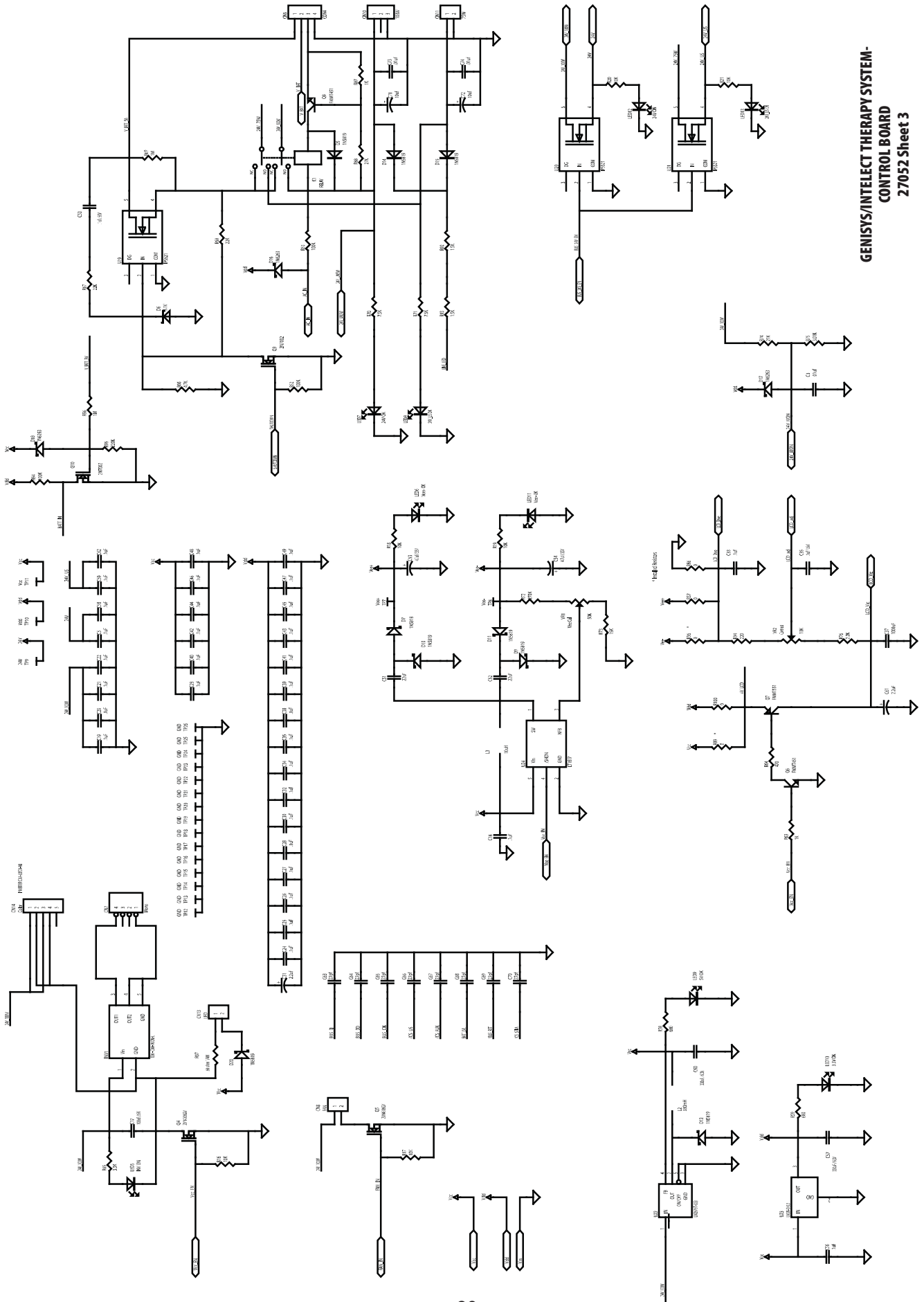

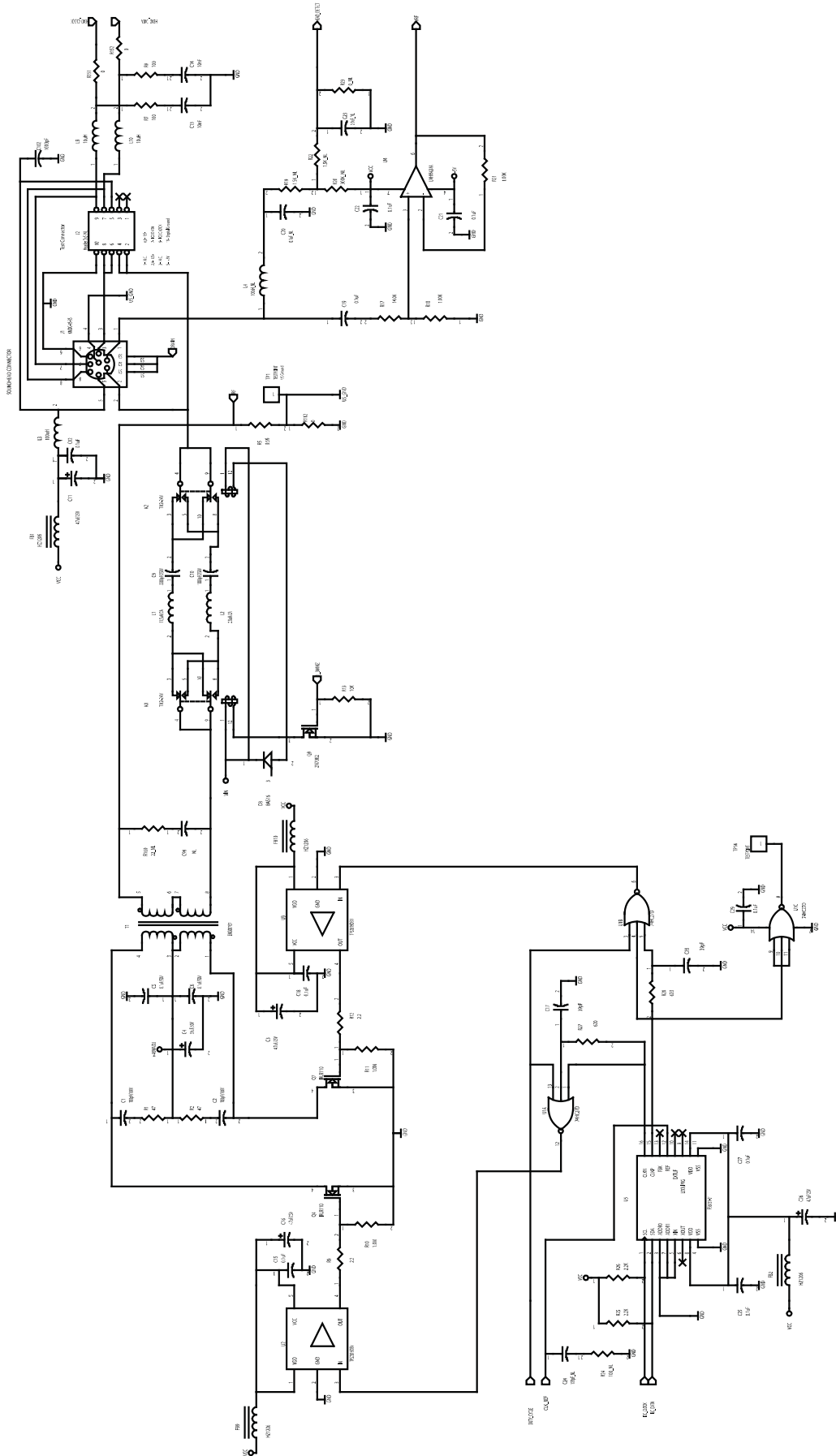

**GENISYS/INTELECT THERAPY SYSTEM-
ULTRASOUND PC BOARD
27055 Sheet 1**

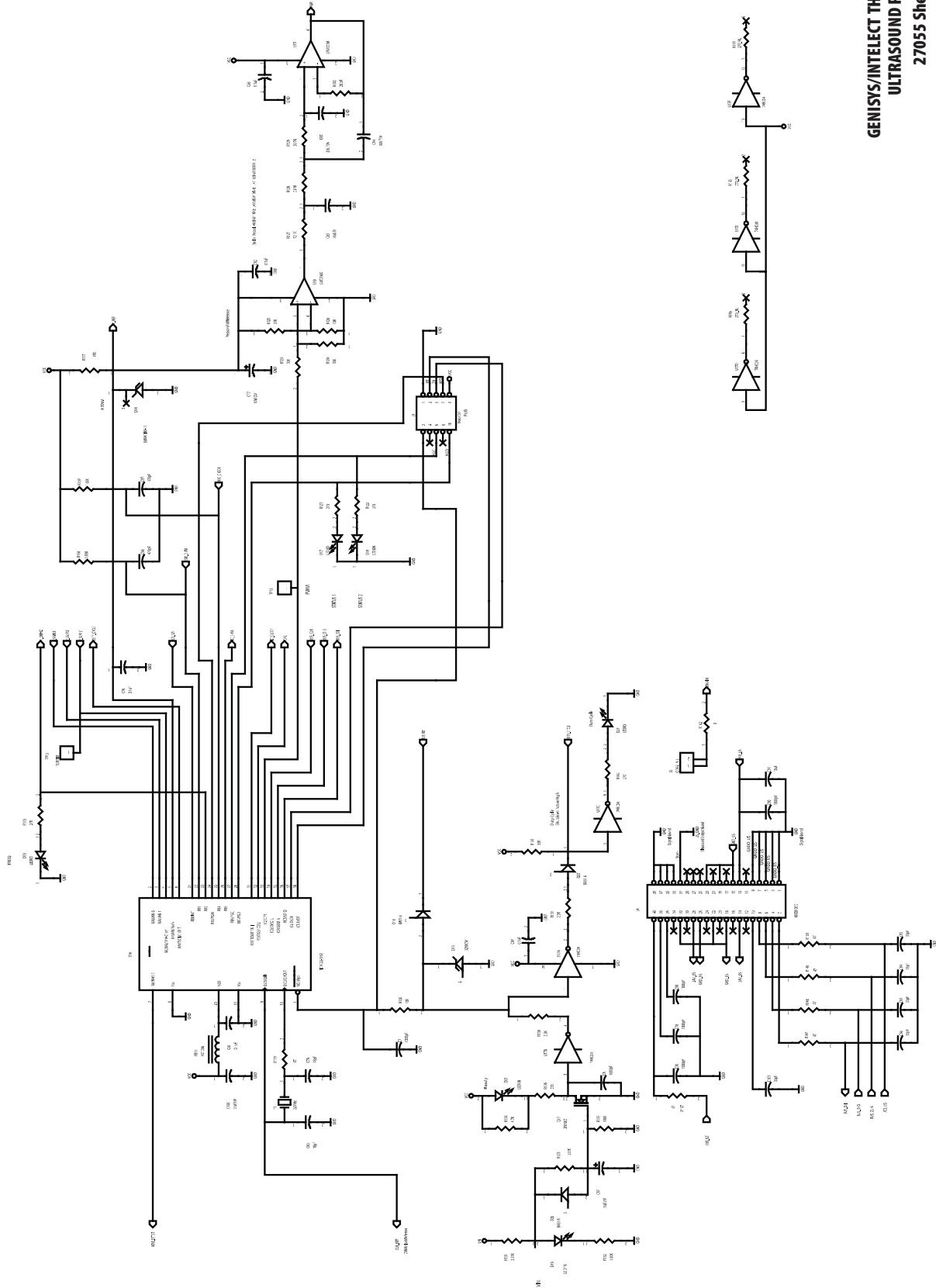

**GENISYS/INTELECT THERAPY SYSTEM-
ULTRASOUND PC BOARD
27055 Sheet 2**

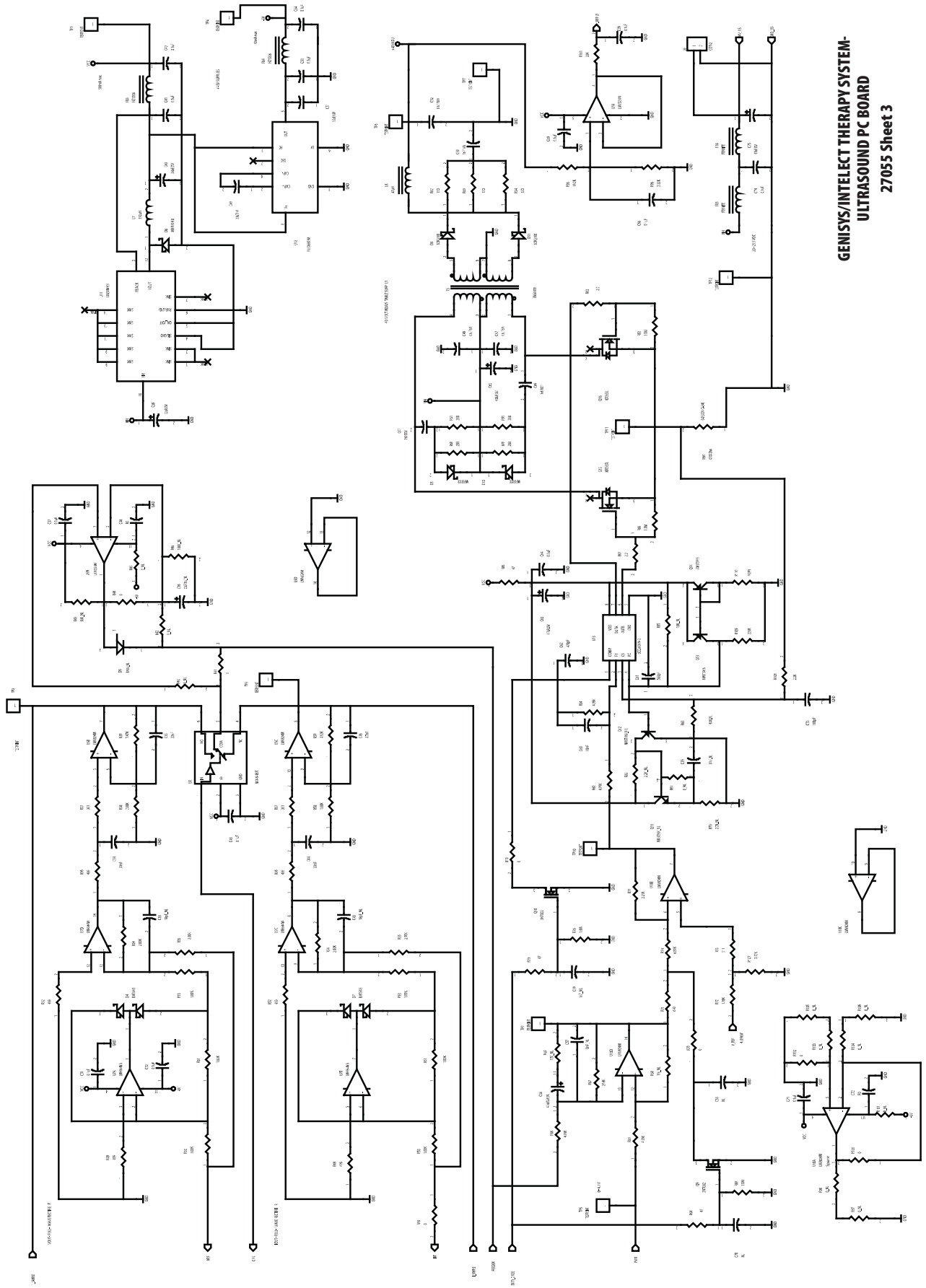

**GENISYS/INTELECT THERAPY SYSTEM-
ULTRASOUND PC BOARD
27055 Sheet 3**

**GENISYS/INTELECT THERAPY SYSTEM-
STIM BOARD
27057 Sheet 1**

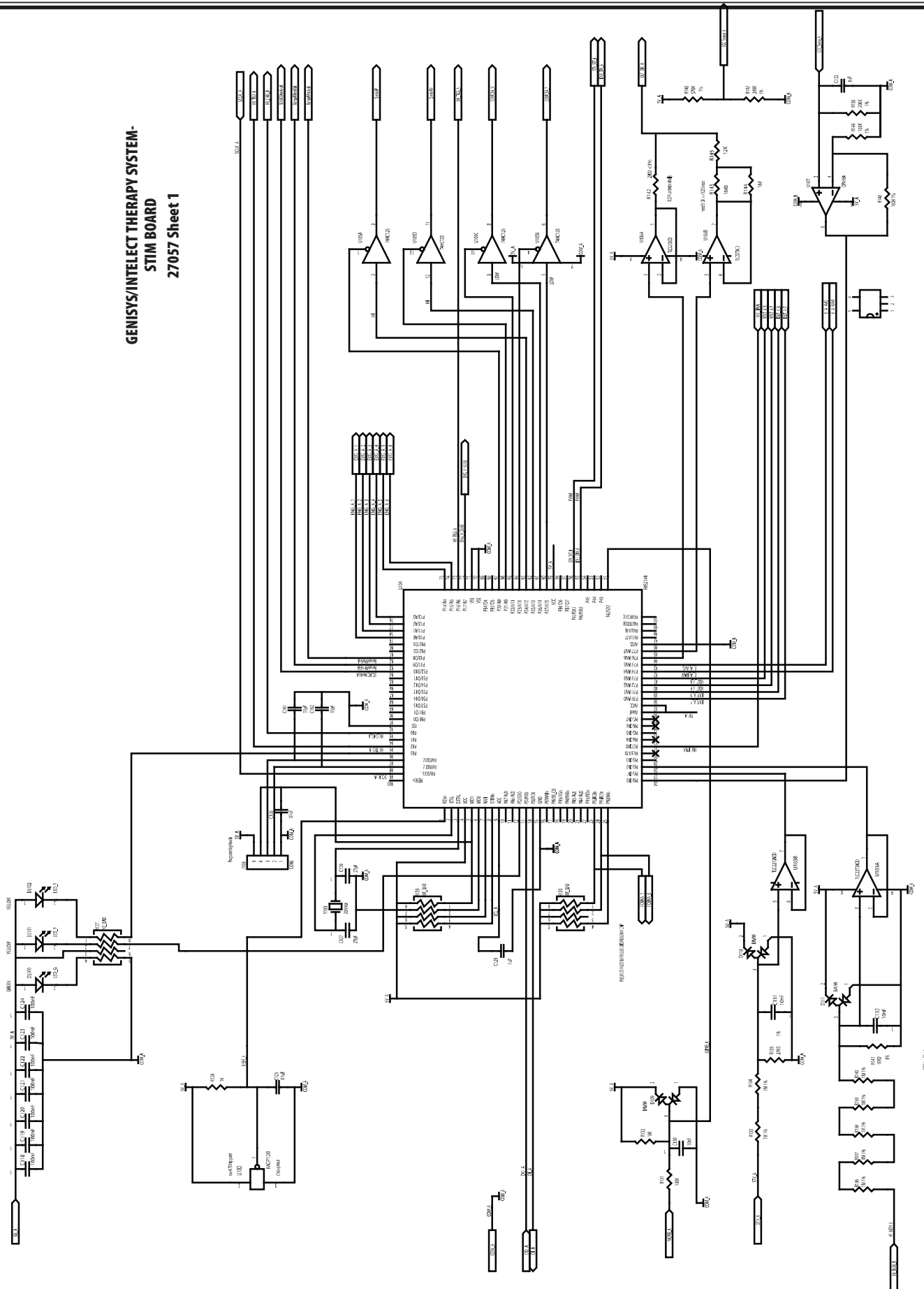

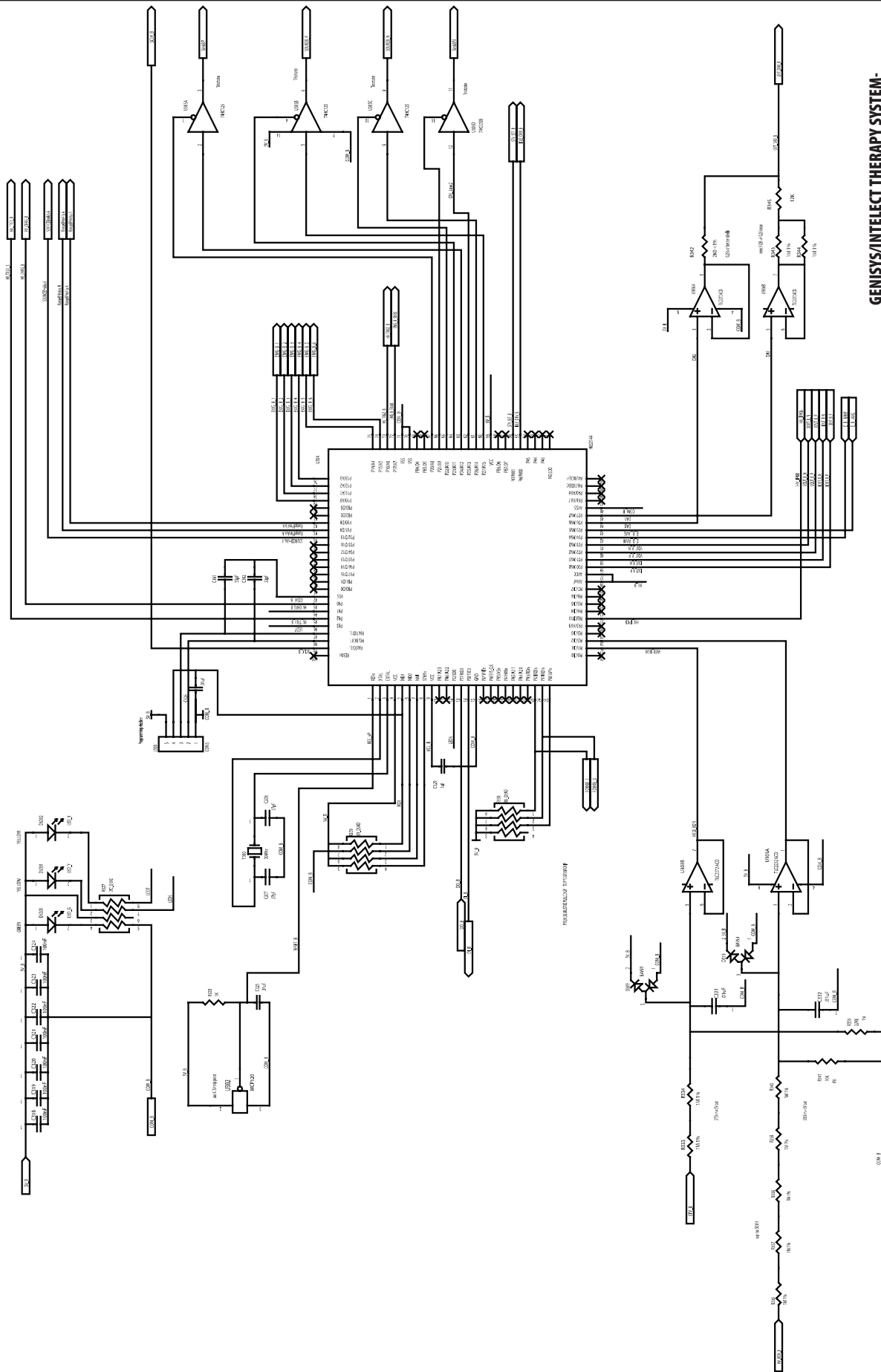

**GENISYS/INTELLECT THERAPY SYSTEM-
STIM BOARD**
27057 Sheet 2

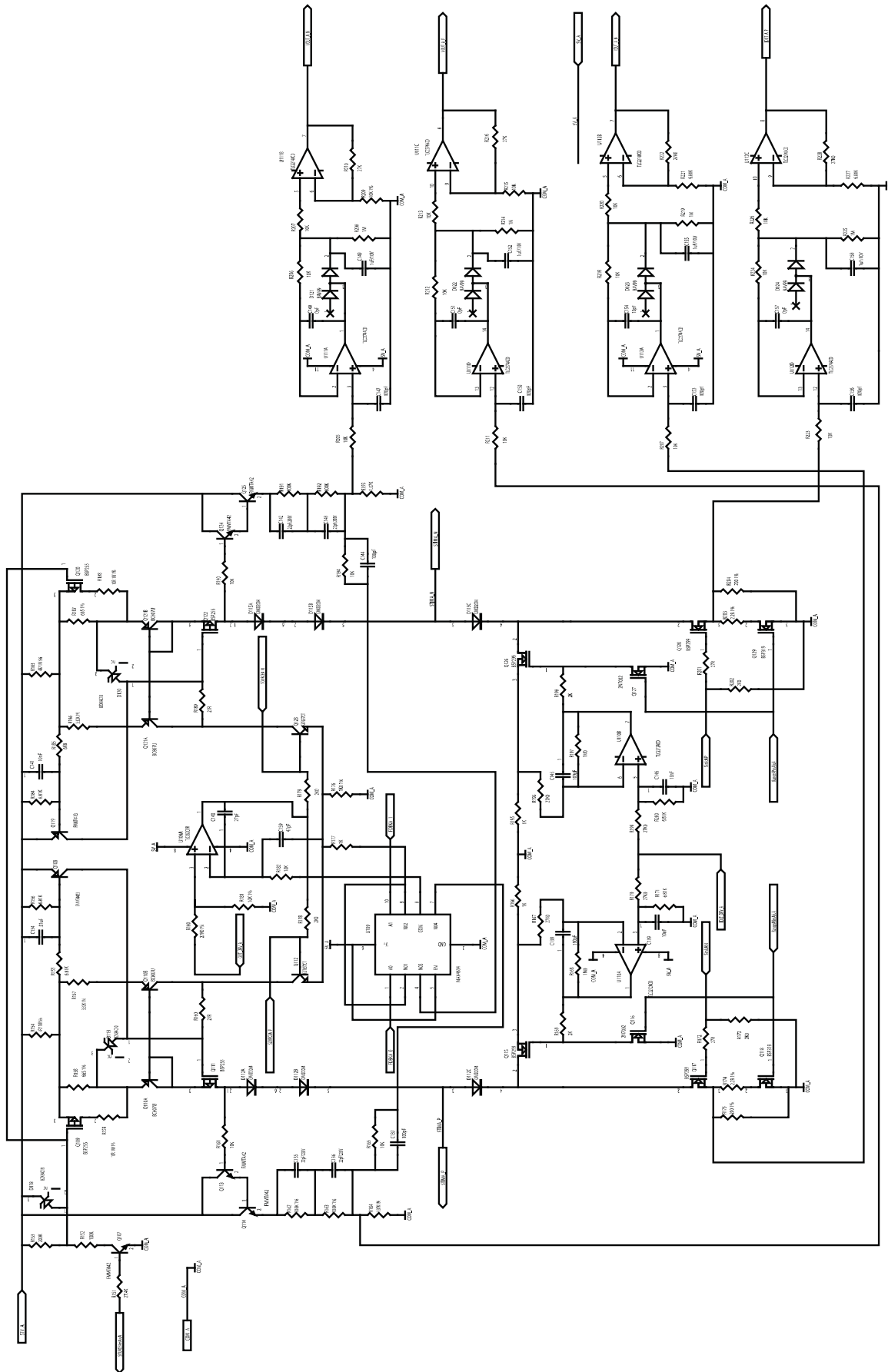

**GENISYS/INTELLECT THERAPY SYSTEM-
STIM BOARD
27057 Sheet 3**

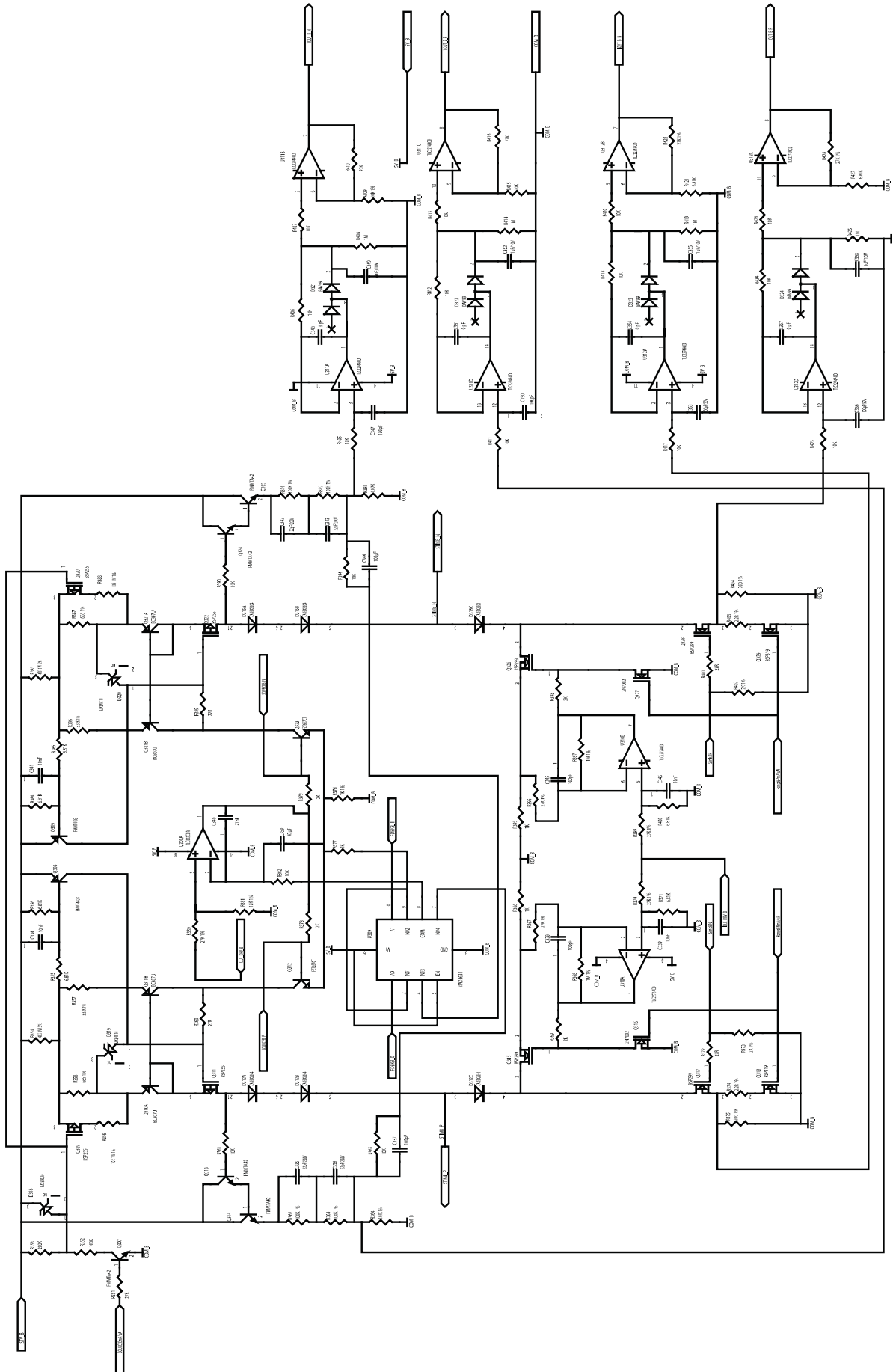

**GENISYS/INTELECT THERAPY SYSTEM-
STIM BOARD**
27057 Sheet 4

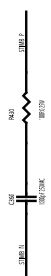

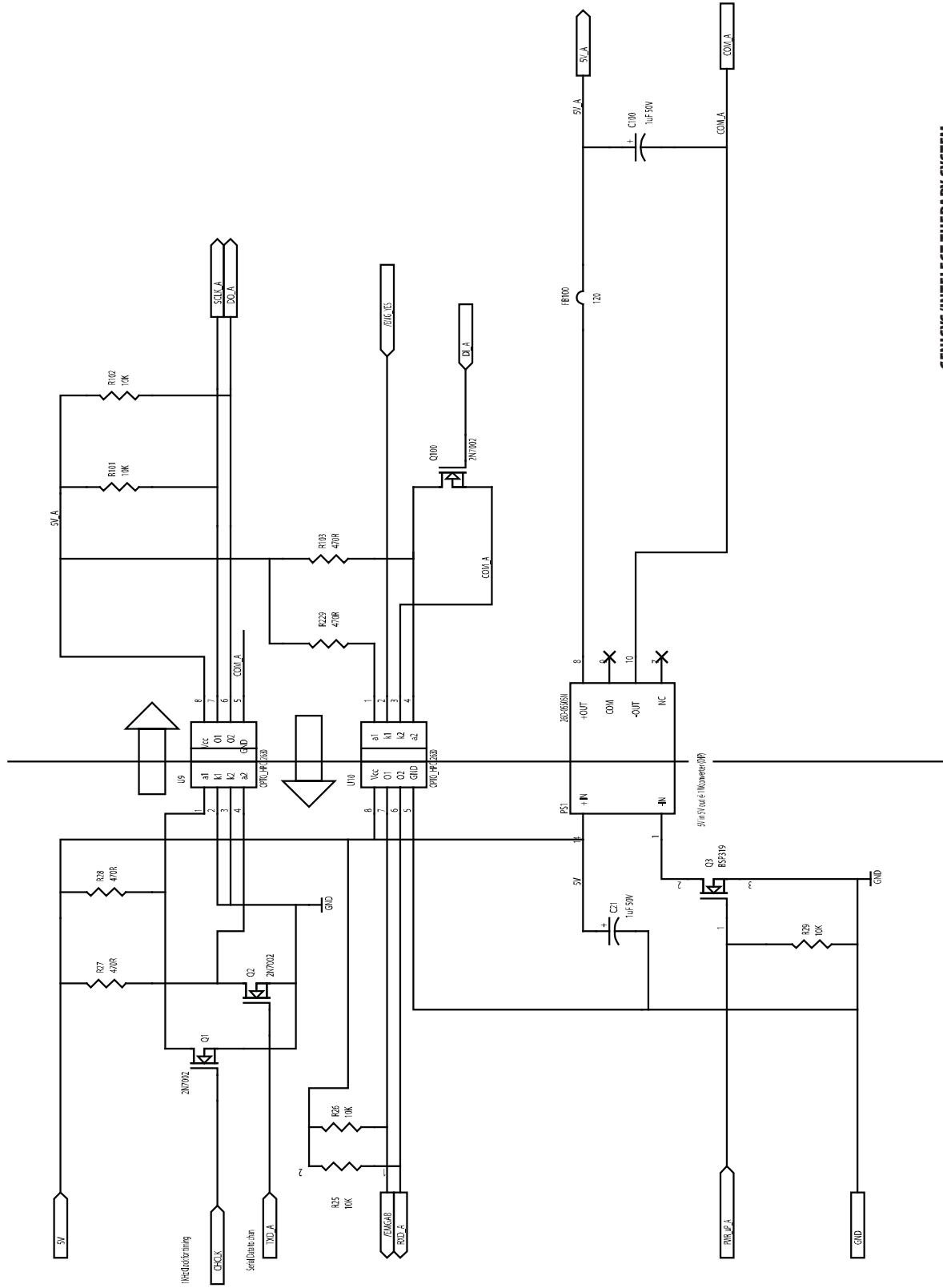

**GENISYS/INTELECT THERAPY SYSTEM-
STIM BOARD
27057 Sheet 5**

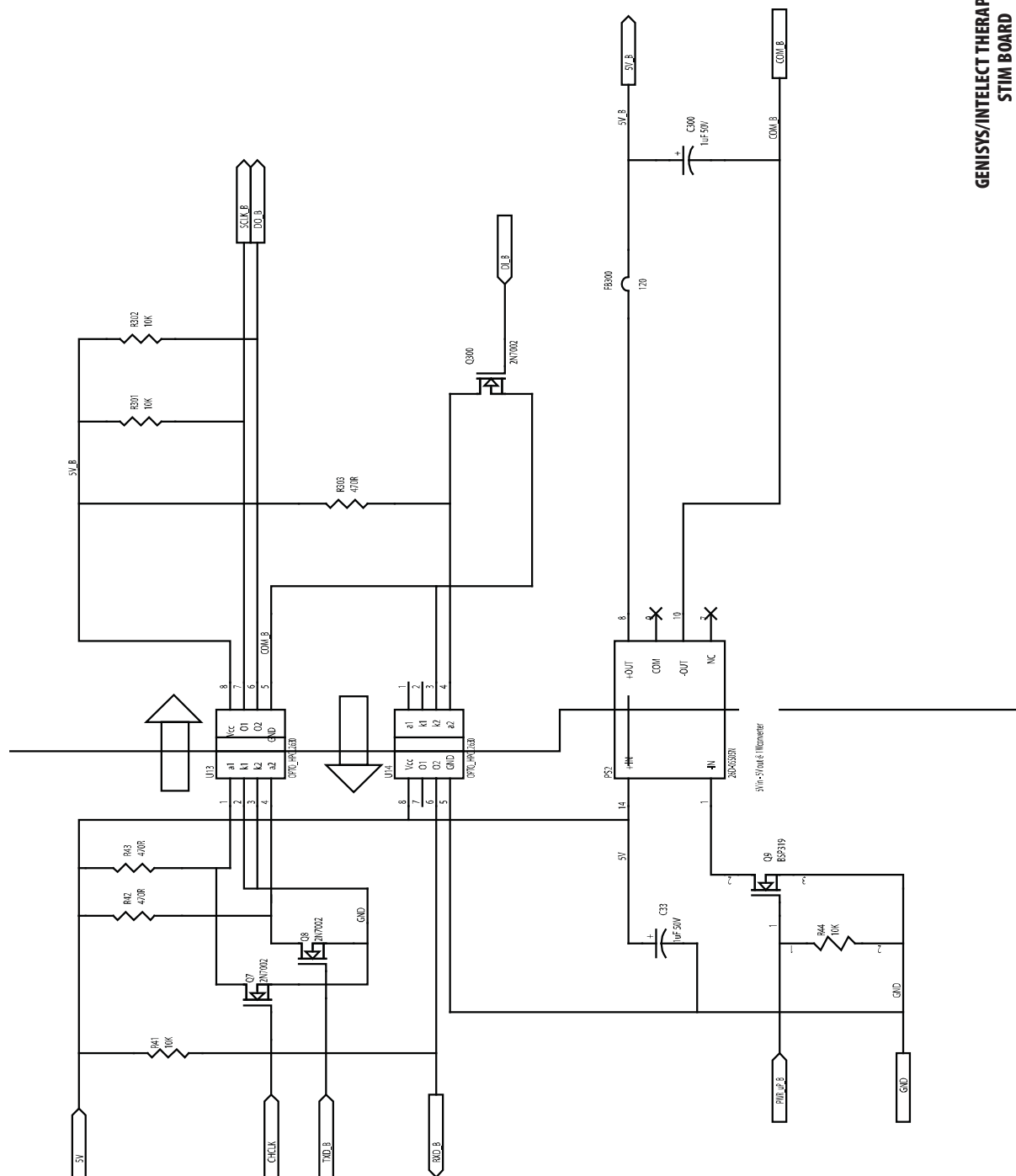

GENESIS/INTELECT THERAPY SYSTEM-
STIM BOARD
27057 Sheet 6

**GENISYS/INTELLECT THERAPY SYSTEM-
STIM BOARD
27057 Sheet 7**

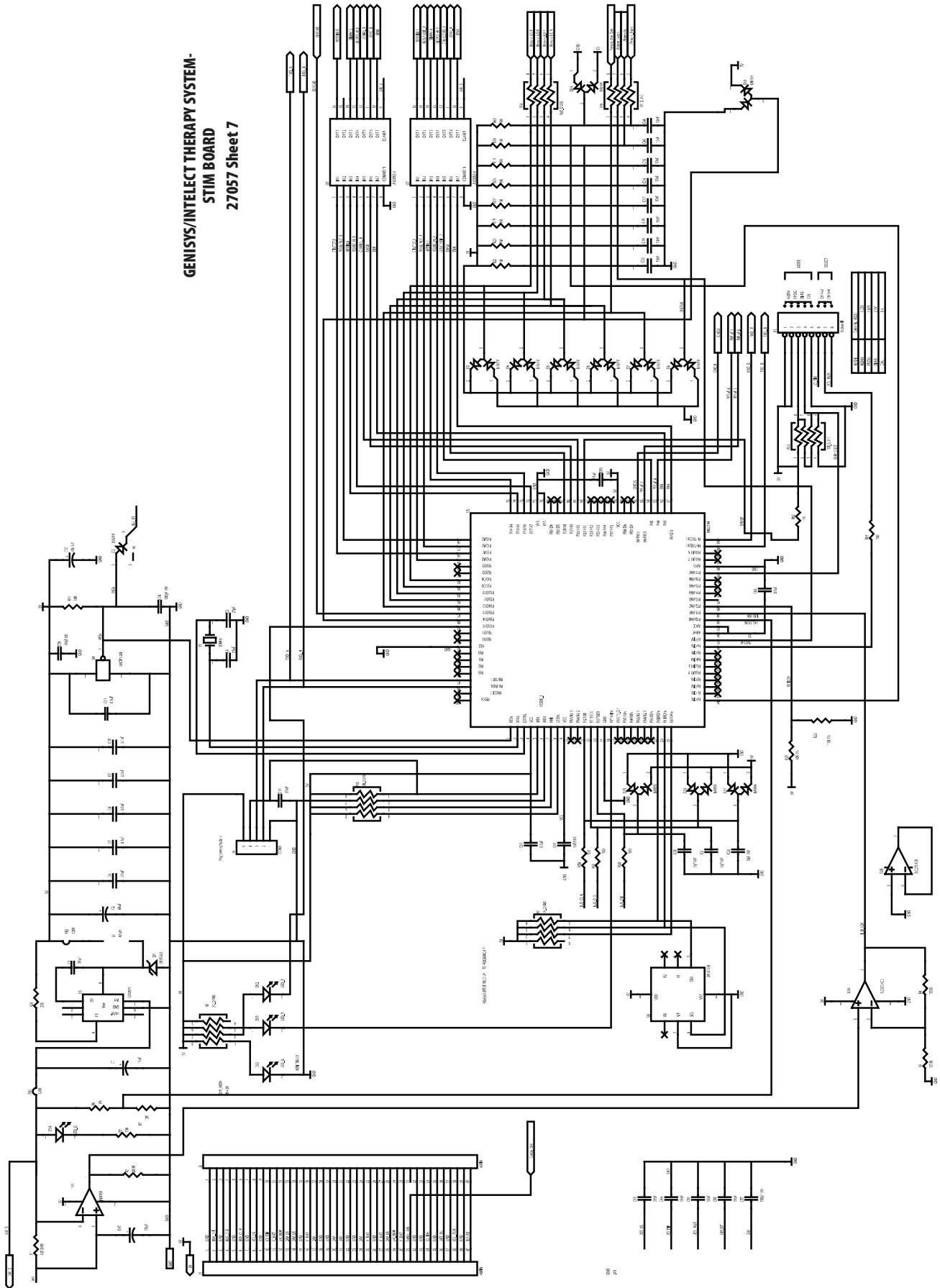

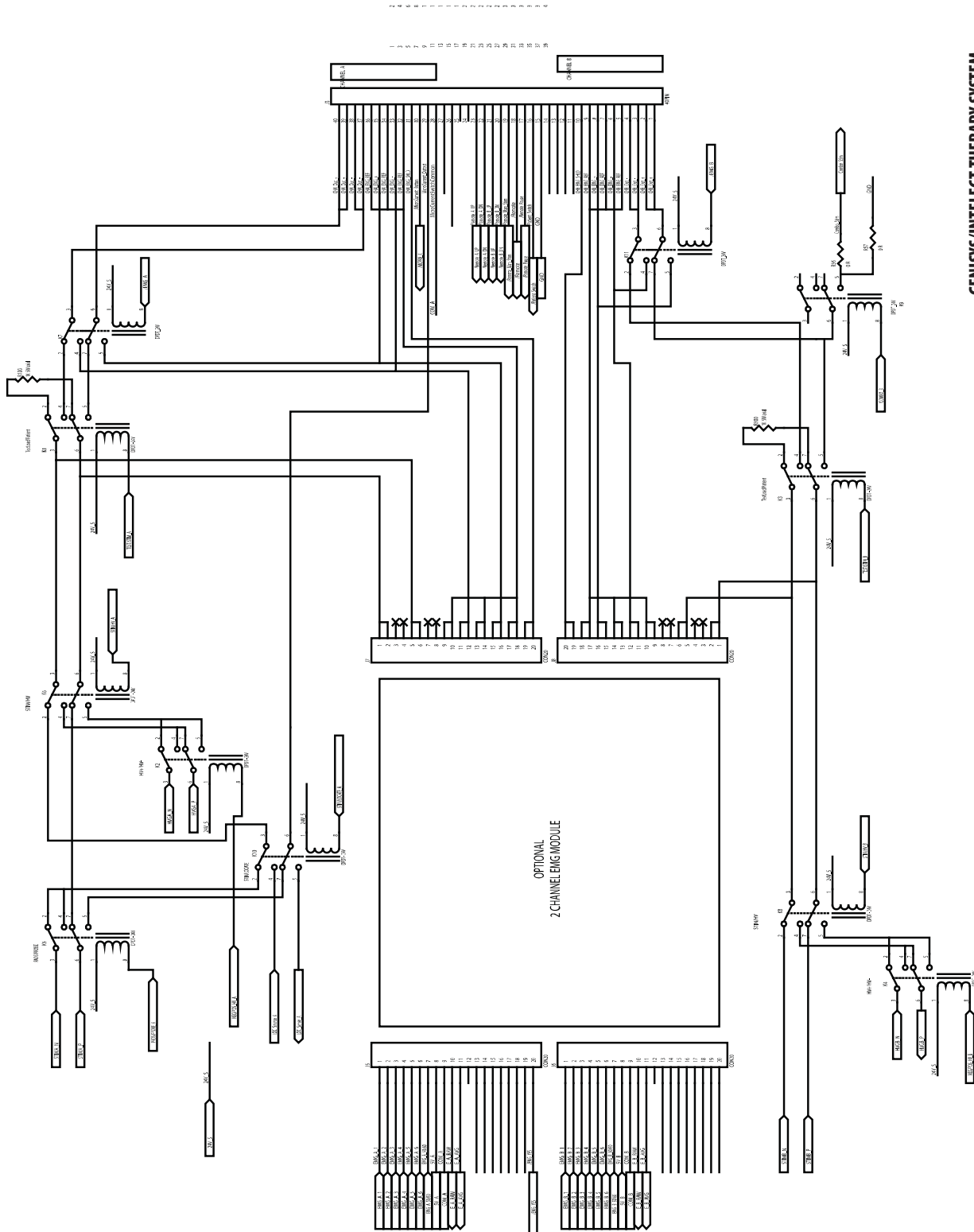

GENISYS/INTELECT THERAPY SYSTEM-STIM BOARD
27057 Sheet 8

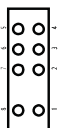

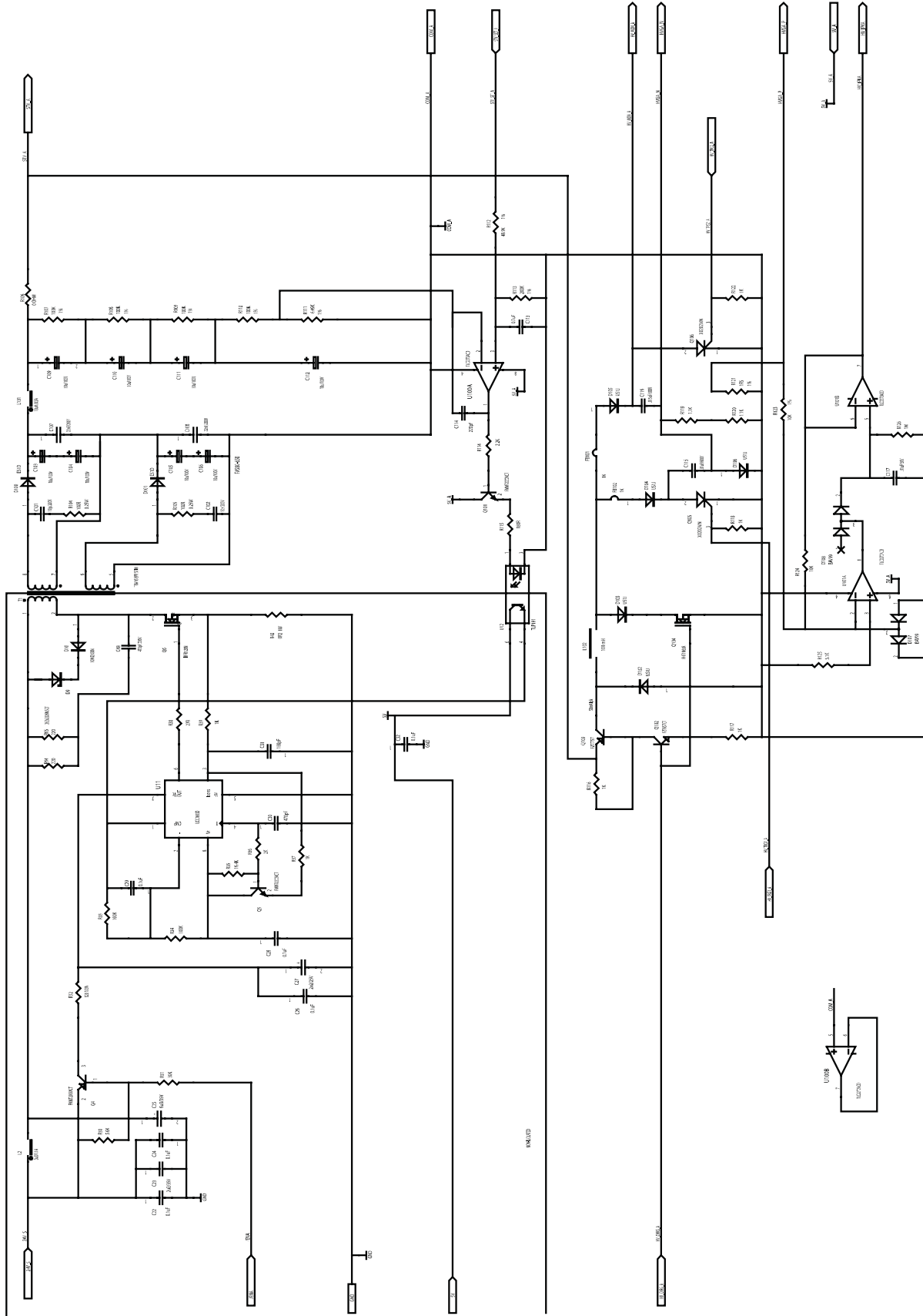

**GENISIS/INTELECT THERAPY SYSTEM-
STIM BOARD
27057 Sheet 9**

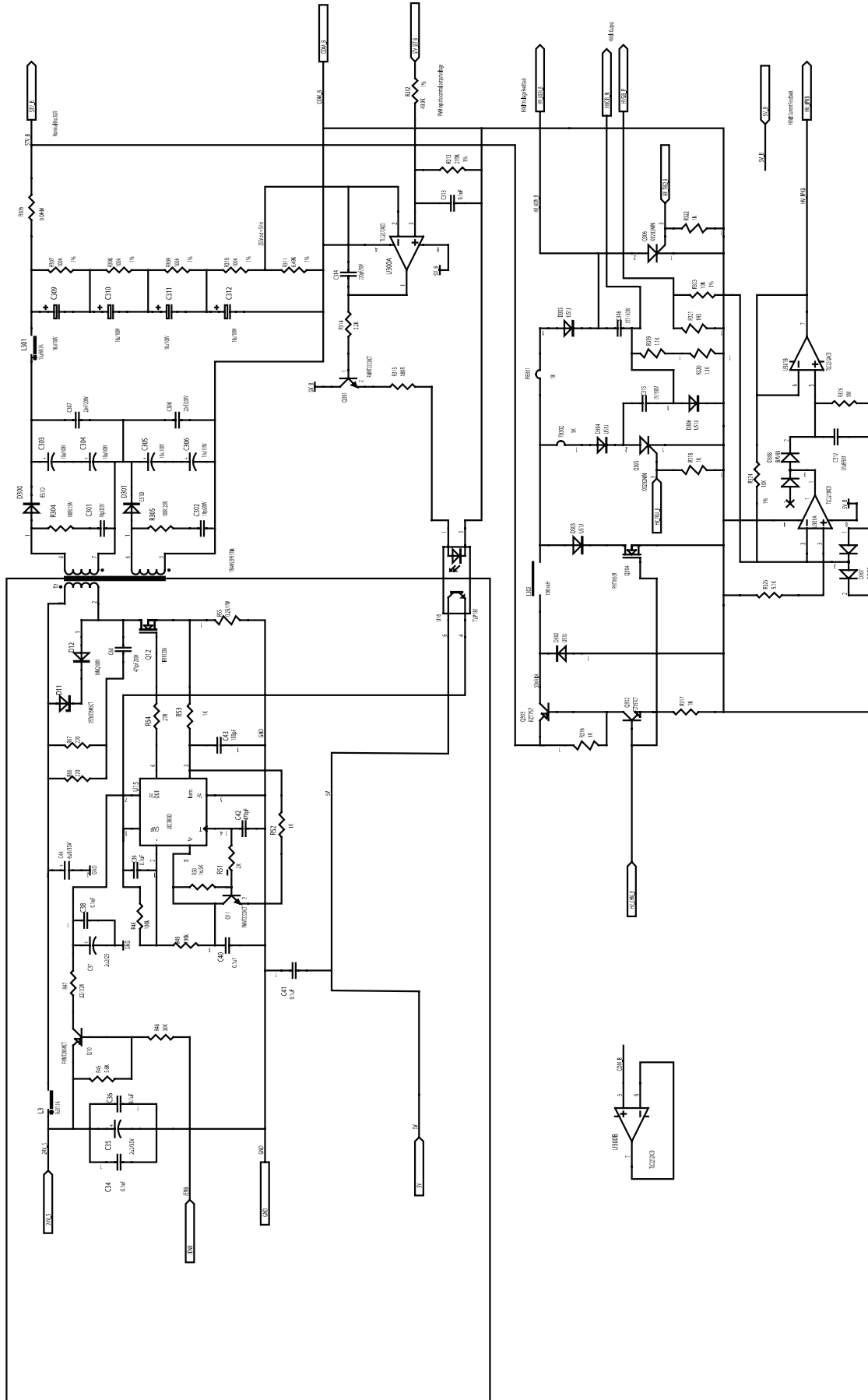

**GENISYS/INTELECT THERAPY SYSTEM-
STIM BOARD**
27057 Sheet 10

10- SCHEMATICS

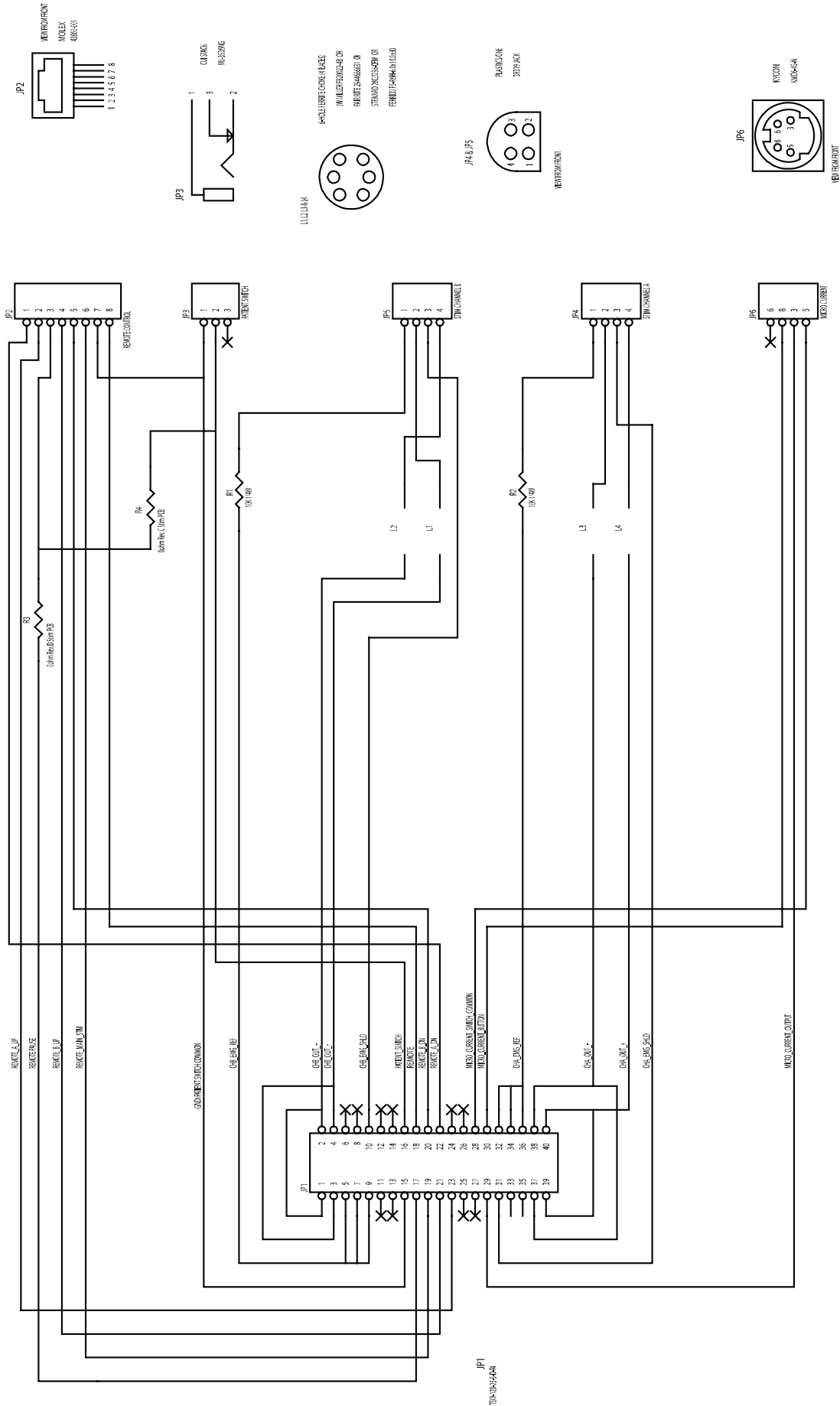

**GENISYS/INTELECT THERAPY SYSTEM-
CONNECTOR BOARD
27059**

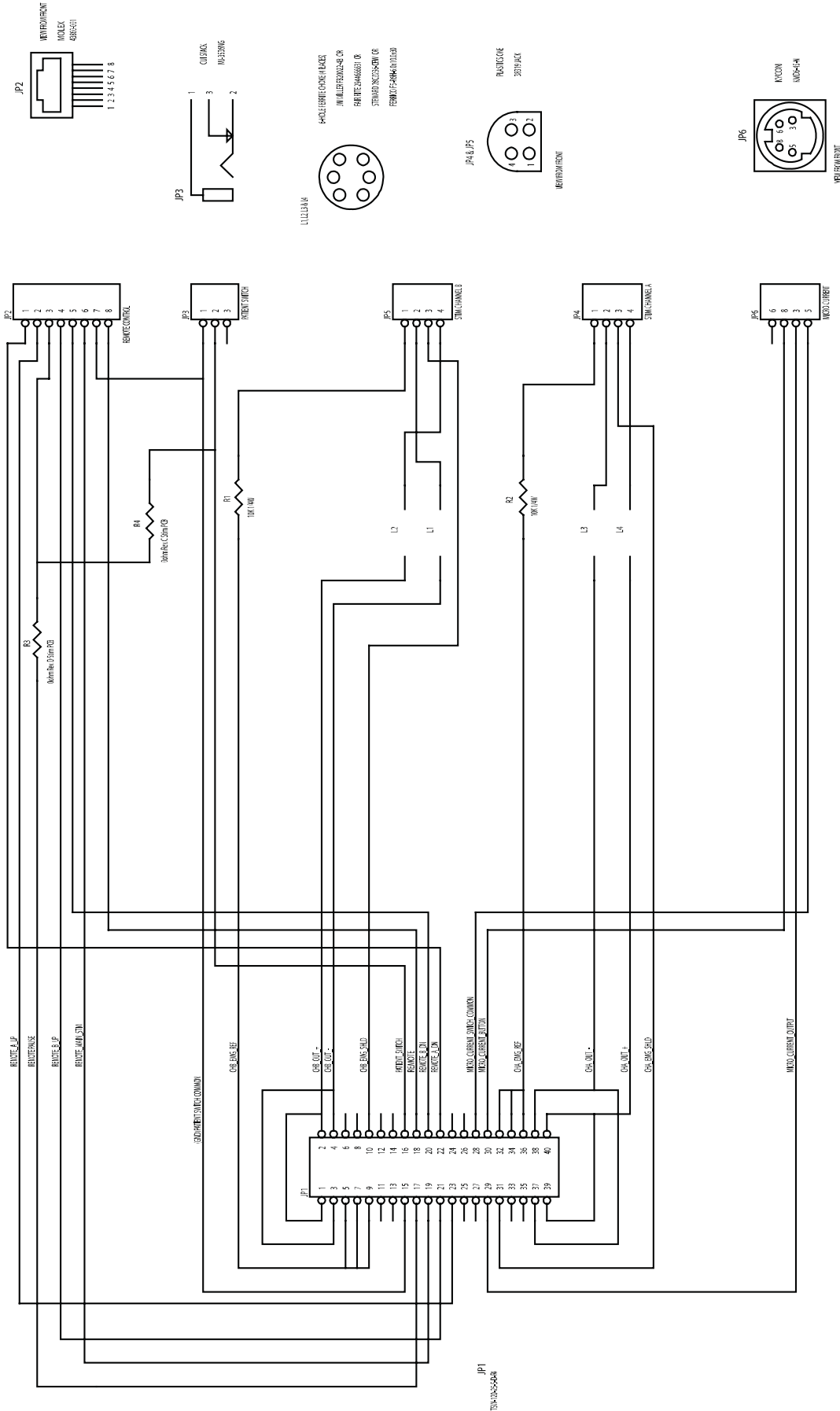

**GENISYS/INTELLECT THERAPY SYSTEM-
CHANNEL 3/4 ELECTROTHERAPY MODULE
CONNECTOR BOARD**
27061

27049- 75 Watt Power Supply (Combination Systems Only)

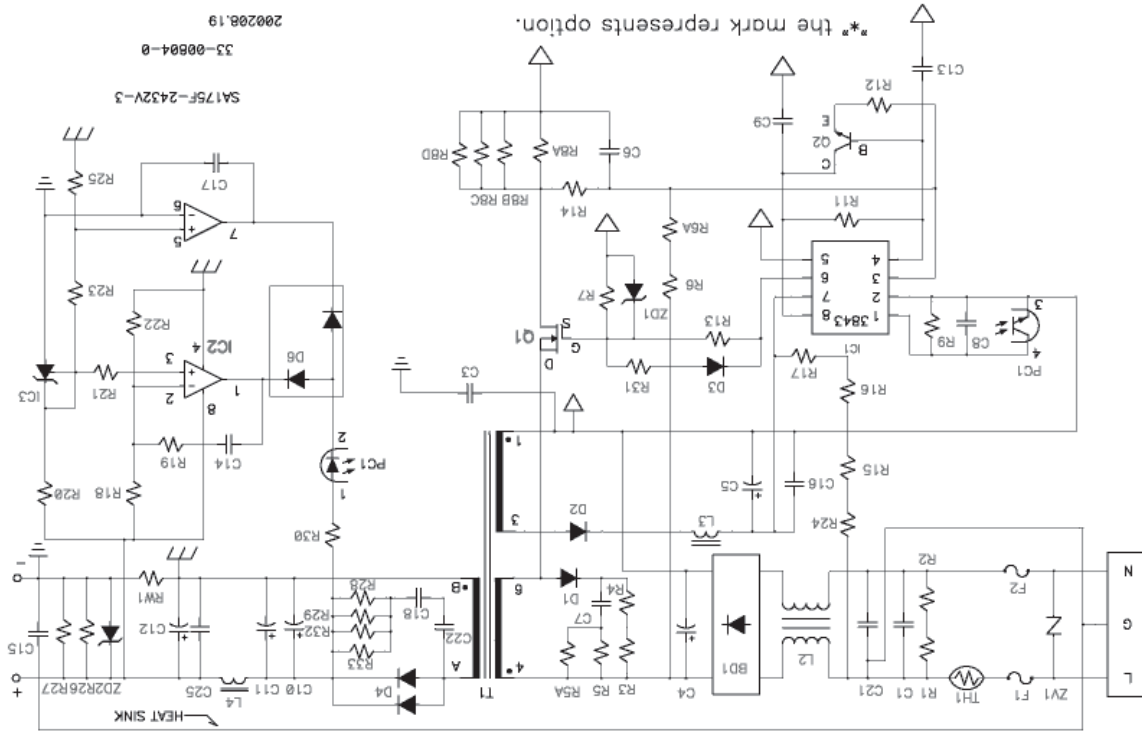

27048- 100 Watt Power Supply

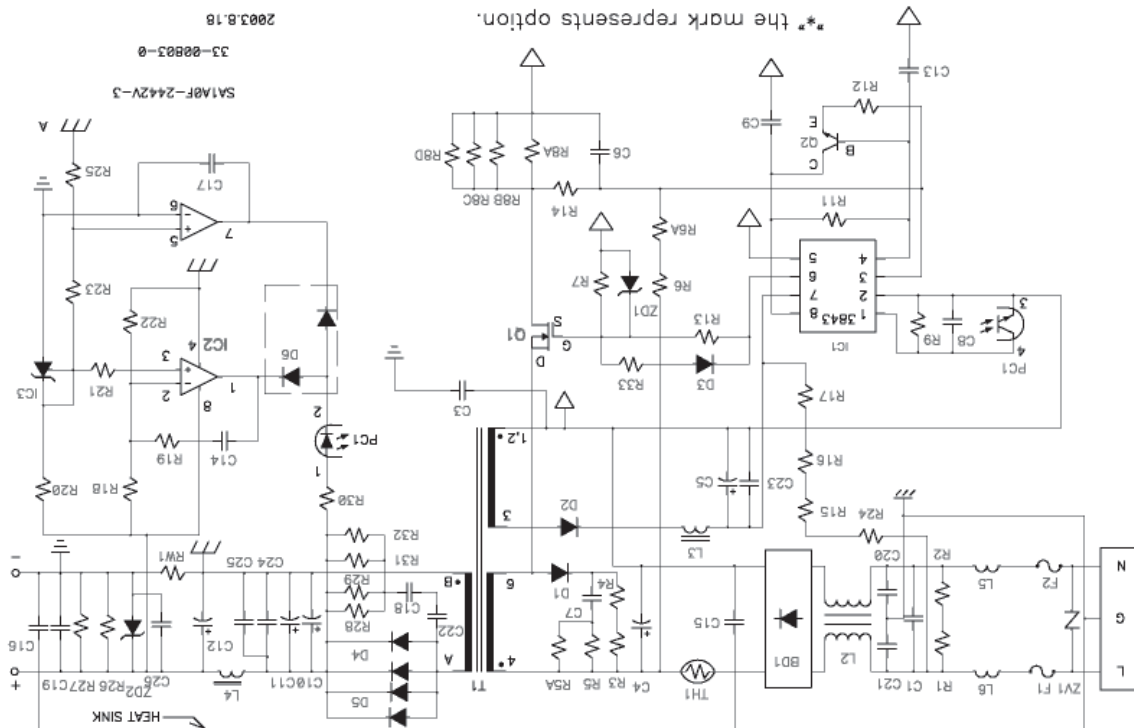

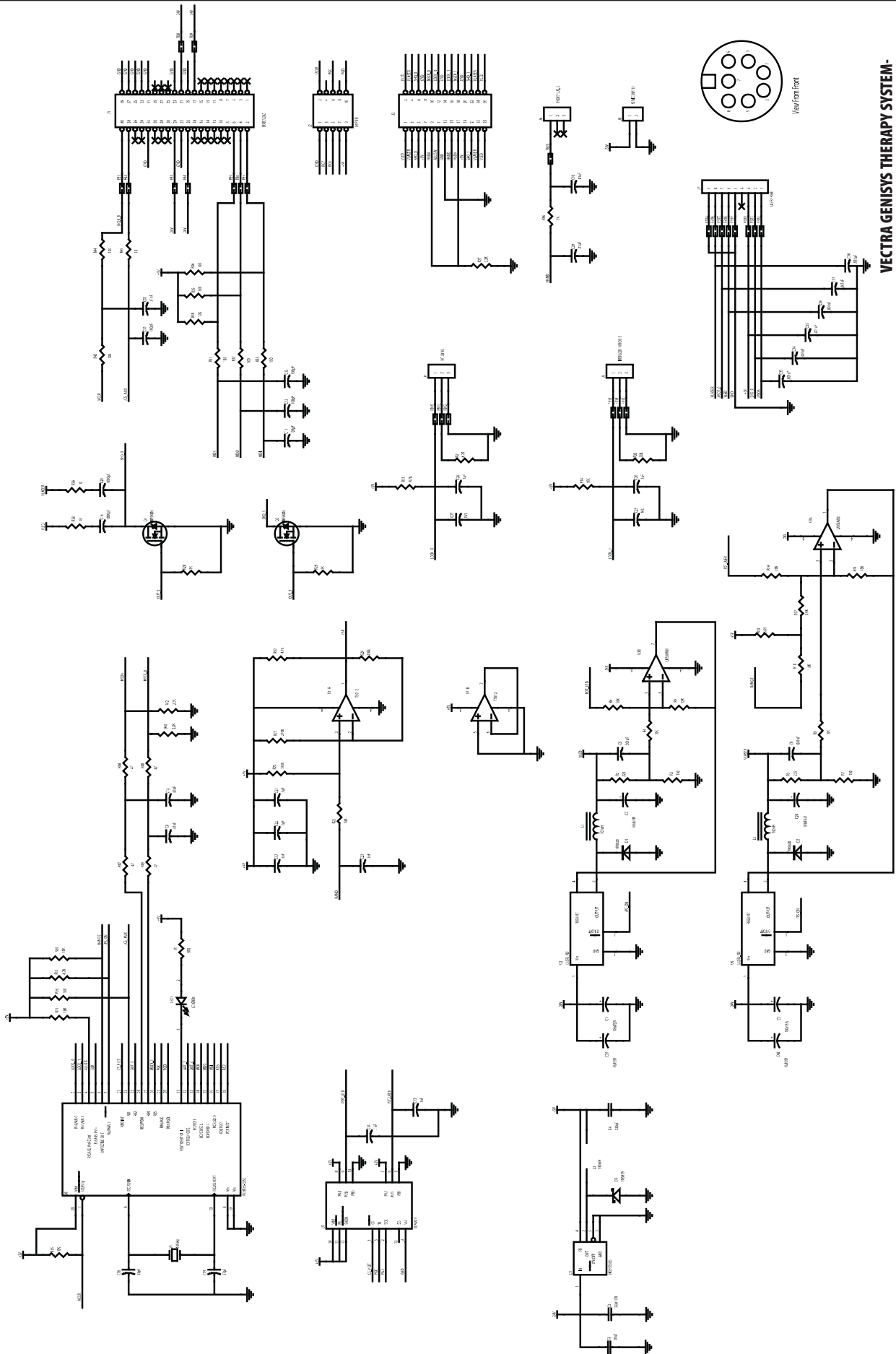

**VECTRA GENISYS THERAPY SYSTEM-
LASER MODULE BOARD
27069**

VECTRA GENISYS, INTELECT LEGEND XT AND INTELECT VET

Chattanooga Group, a division of Encore Medical, L.P. ("Company") warrants that the Vectra Genisys, Intellect Legend XT and Intellect Vet Therapy Systems, Channel 3/4 Electrotherapy Module, Laser Module, and sEMG Module ("Products") are free of defects in material and workmanship. This warranty shall remain in effect for two years (24 months) from the date of original consumer purchase. If these Products fail to function during the two year warranty period due to a defect in material or workmanship, at the Company's Option, Company or the selling dealer will repair or replace the respective Product without charge within a period of thirty (30) days from the date on which the Product is returned to the Company or the dealer.

All repairs to the Product must be performed by a service center certified by the Company. Any modifications or repairs performed by unauthorized centers or groups will void this warranty.

The warranty period for certain accessories is 90 days. Accessories consist of Lead Wires, Operator Remote, Electrodes, Patient Data Cards, sEMG Data Cards, and Nylatex .

The warranty period for the Therapy System Cart, Battery Module, Ultrasound Applicators, and Laser Applicators is one year (12 Months).

This Warranty Does Not Cover:

- Replacement parts or labor furnished by anyone other than the Company, the selling dealer, or a certified Company service technician.
- Defects or damage caused by labor furnished by someone other than Company, the selling dealer or a certified Company service technician.
- Any malfunction or failure in the Product caused by product misuse, including, but not limited to, the failure to provide reasonable and required maintenance or any use that is inconsistent with the Product User's Manual.

COMPANY SHALL NOT BE LIABLE IN ANY EVENT FOR INCIDENTAL OR CONSEQUENTIAL DAMAGES.

Some locations do not allow the exclusion or limitation of incidental or consequential damages, so the above limitation or exclusion may not apply to you.

To obtain service from Company or the selling dealer under this warranty:

1. A written claim must be made within the warranty period to the Company or the selling dealer. Written claims made to the Company should be sent to:

Chattanooga Group
4717 Adams Road
Hixson, TN 37343 USA
Telephone: 1-423-870-2281 or 1-800-592-7329
Facsimile: 1-423-875-5497

and

2. The Product must be returned to the Company or the selling dealer by the owner. A Return Authorization (RA) Number must be obtained before returning any product to the Company.

This warranty gives you specific legal rights and you may also have other rights which vary from location to location.

The Company does not authorize any person or representative to create for it any other obligation or liability in connection with the sale of the Product.

Any representative or agreement not contained in the warranty shall be void and of no effect.

THE FOREGOING WARRANTY IS IN LIEU OF ALL OTHER WARRANTIES, EXPRESSED OR IMPLIED, INCLUDING ANY WARRANTY OR MERCHANTABILITY OR FITNESS FOR A PARTICULAR PURPOSE.

ALL LASER SERVICE AND THE REQUIRED ANNUAL CALIBRATION FOR LASER MUST BE PERFORMED BY THE COMPANY.

PERFORMANCE OR ATTEMPT OF ANY FIELD SERVICE OR CALIBRATION OF THE LASER MODULE OR ANY OF THE LASER APPLICATORS WILL RENDER THIS WARRANTY VOID.

**Moving
Rehabilitation
Forward™**



ISO 13485 CERTIFIED

4717 Adams Road
P.O. Box 489
Hixson, TN 37343 U.S.A.
1-423-870-2281 U.S.A.
1-800-592-7329 U.S.A.
1-423-875-5497 U.S.A. FAX
chattgroup.com

* 28047 *

28047D

© 2008 Encore Medical, L.P.