

**MODEL** | **32500**

**OWNER'S MANUAL**  
AND INSTRUCTION GUIDE



**PRODUCT  
FEATURES**

**ASSEMBLY**

**OPERATING  
INSTRUCTIONS**

**WARRANTY**

**BEFORE USE:**



Ensure the product has been assembled according to the instructions in this manual.

All operators should have received or read and understood the instructions for safe and proper operation of the Protekt® Dash.

# Thank you for choosing Proactive!

To better serve you, please record  
the following information:

Supplier Name: \_\_\_\_\_

Telephone: \_\_\_\_\_

Serial #: \_\_\_\_\_

Date of Purchase: \_\_\_\_\_

## INSPECT YOUR MERCHANDISE

Upon receipt of your Protekt® Dash, verify that all merchandise is complete and free from any shipping damage. Refuse delivery if the packaging appears to be badly damaged. If the merchandise is received damaged or is missing components, contact the shipping company immediately and file a claim.

For further assistance, contact your local dealer or Proactive at the following:

Proactive Medical Products  
270 Washington Street  
Mount Vernon, NY 10553  
855-237-7622  
[www.proactivemedical.com](http://www.proactivemedical.com)

# SAFETY INSTRUCTIONS

- **FAILURE** to use this device according to instructions may cause serious injury.
- **NEVER** attempt to transfer a patient or resident whose weight exceeds the indicated maximum capacity for this device or any accessory.
- **NEVER** leave a patient unattended during transfer.
- **DO NOT** use without complete understanding of safe and correct operation.
- **DO NOT** use for the purpose of transportation over long distances.
- **DO NOT** use for the purpose of seating over long extended periods of time.



## DEFINITIONS

In this manual the user refers to the patient or resident and may be used interchangeably at different times. Caregiver refers to the operator or person who is assisting with the transfer.

Symbols used in this manual and their meanings:



Warning! Failure to heed this warning may result in damage to the product or serious injury to the operator and/or user.



Important instructions to follow. Read and understand the instructions in the manual before using the product.



Note! Important information concerning the product and/or its correct and proper usage to follow.

# PRODUCT FEATURES

## DESCRIPTION & APPLICATIONS

The Protekt® Dash from Proactive represents a class of medical devices collectively referred to as a standing transfer aid. The Protekt® Dash standing transfer aid is positioned between a traditional walker or wheelchair and the common electric stand assist patient lift. The Protekt® Dash is a transfer assist unit which keeps the user actively engaged in the process. Transfer functions of all types are quick and require minimal caregiver assistance. Each unit is equipped with a crossbar where users can grasp and pull their self up into a standing position using their own strength. The padded split seats swing out allowing the user to stand up and board the unit. The caregiver then flips the split seats back into place to form a secure and comfortable seat for the user to sit on for the remainder of the transfer.

A patient or resident who qualifies to use the Protekt® Dash must have enough leg and lower body strength to stand up and remain in the standing/sitting position. Adequate arm strength is required if the patient must use crossbar. Users who satisfy these criteria and have difficulty walking or present a potential for falling down will find the Protekt® Dash a useful and safe transfer device. For patients who lack these requirements, a sit-to-stand lift such as the electric powered patient lift is preferred and recommended.

The Protekt® Dash is suitable for the following types of transfers:

- Bed to Chair/Wheelchair
- Bed/Chair/Wheelchair to commode
- Room to Room



# SPECIFICATIONS & OPTIONS

<b>Protekt® Dash</b>	
Maximum Capacity	500 Lbs. / 227 Kg
Minimum Base Width	26.8
Maximum Base Width	37"*
Open Base Width	37"*
Closed Base Width	26.7"
Base opens	Yes
Overall Height	43.3"
Base Height	4.5"
Minimum Seat Height	26.7"***
Seat Width	20"
Overall Length	35.4"
Unit Weight	78Lbs.
Knee Pads / Shin Guards	Yes
Optional Support Strap	Yes
Optional Seat Locks	Yes

**PRODUCT  
FEATURES**

*\*Measured to the outside of each base leg with the base legs in the widest open position*

*\*\*Measured from the ground to the bottom of the seat*

# ASSEMBLY

**i** Prior to assembly, unpack all parts from the shipping carton and check for any missing parts. Contact your dealer immediately if a part is missing.

## Parts List

1. Cross Bar x 2
2. Right Side Arm
3. Left Side Arm
4. Side Support Arm x 2
5. Knee Pad Support Bar
6. Knee Pad x 2
7. Seat x 2

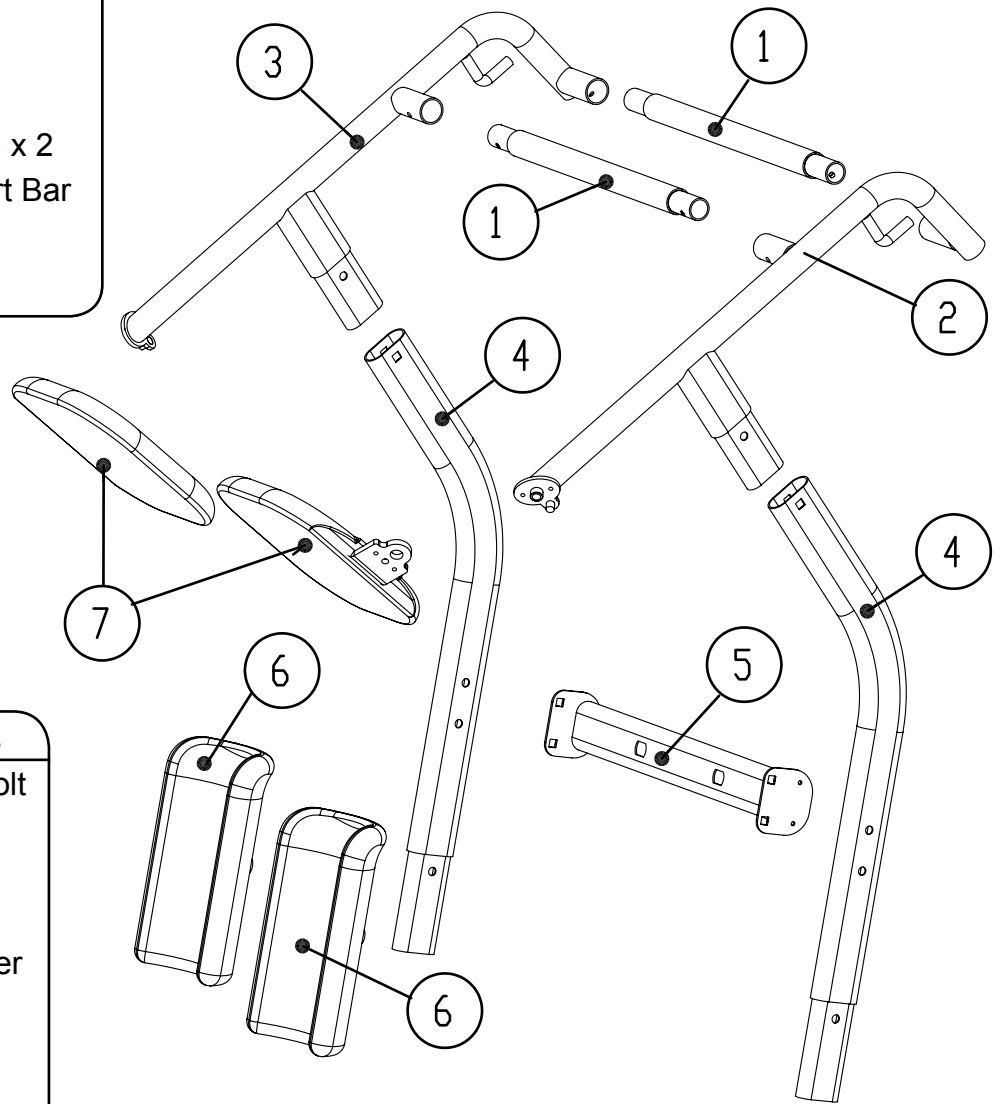

## Tools & Fasteners

- |    |     |               |
|----|-----|---------------|
| A1 | 8x  | Carriage bolt |
| A2 | 2x  | Hex bolt      |
| A3 | 4x  | Hex screw     |
| A4 | 10x | Washer        |
| A5 | 10x | Lock washer   |
| A6 | 8x  | Lock nut      |
| A7 | 2x  | Plastic cap   |
| T1 | 1x  | Wrench        |
| T2 | 1x  | Allen key     |



*Factory assembled base with foot plate and castors*

# STEP BY STEP ASSEMBLY

**1**

Place the base assembly on the floor and lock casters in place for ease of assembly.

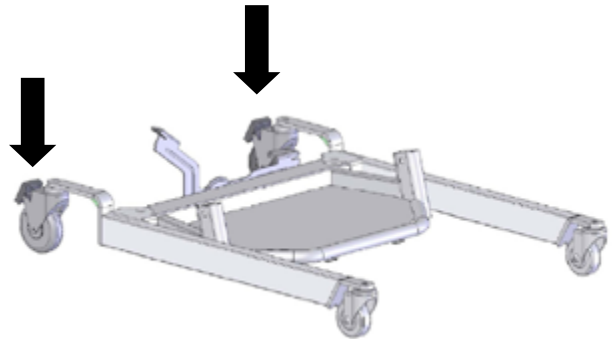

Insert the kneepads into the support bar and secure them in place with bolts and washers (A2 + A5 + A4) as indicated below.

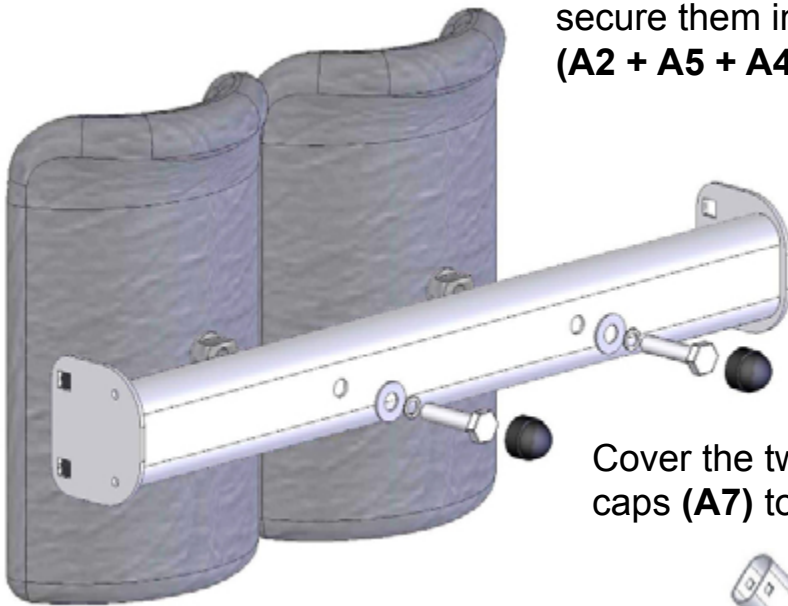

**2**

Cover the two bolt heads with black plastic caps (A7) to complete kneepad assembly.

ASSEMBLY

Install the kneepad assembly between the two side support arms as shown. Fasten in place with four carriage bolts, nuts and washers.

**3**

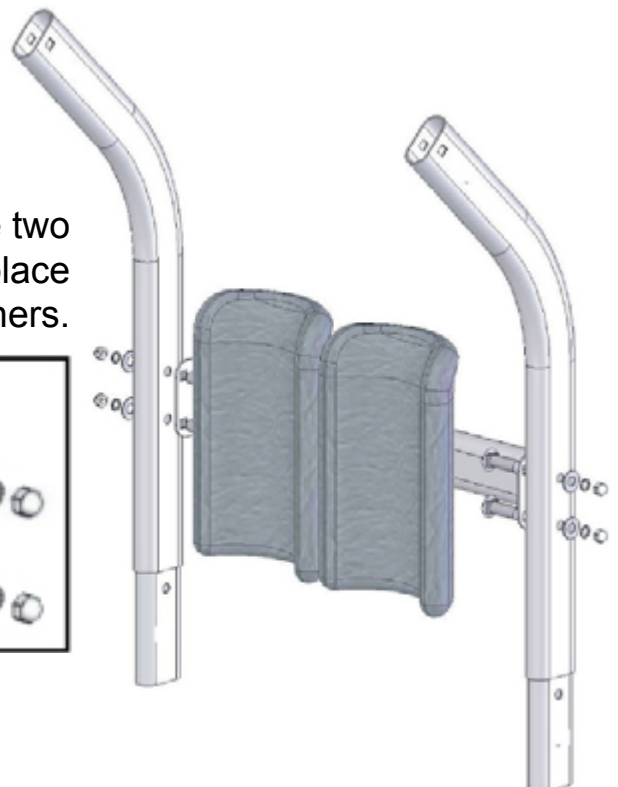
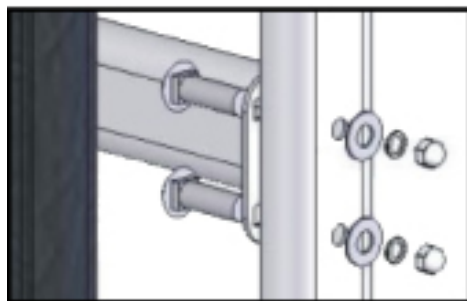

Insert the two cross bars into the holes on the seat and handle bar support units.

Line up the small holes on the underside of the tubes with the holes in the support units.

Use the 4 hex screws (A3) with Allen key (T2) to tighten the completed assembly.

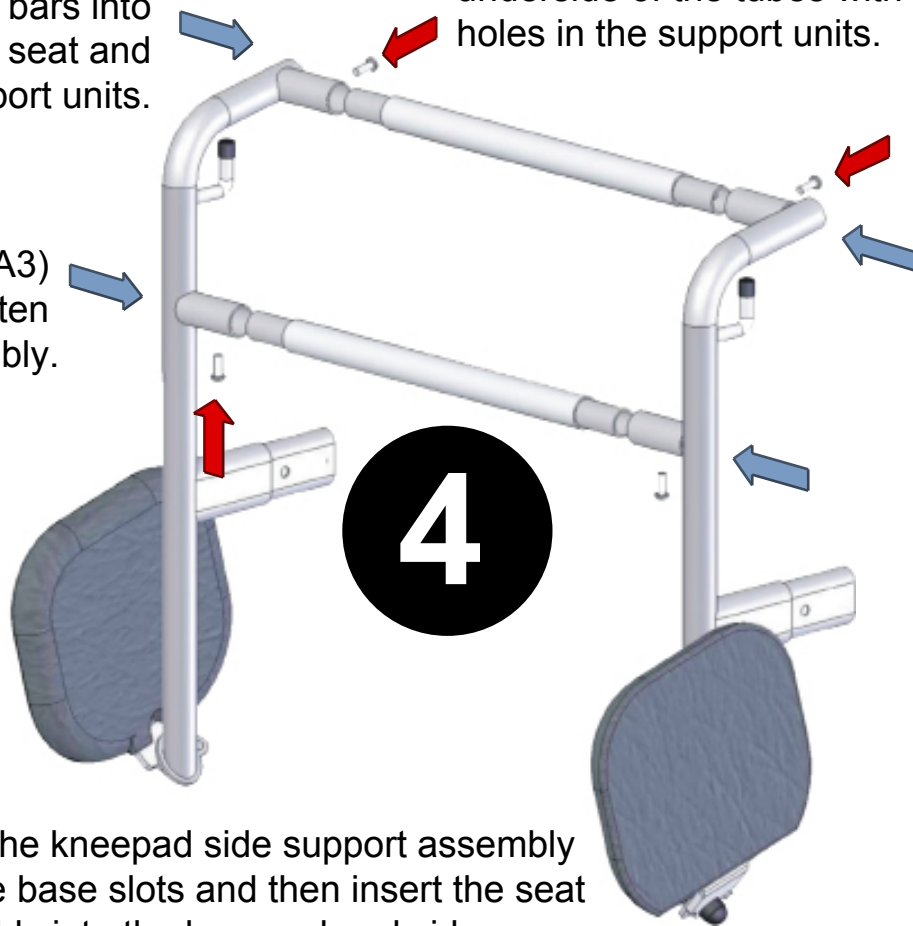

5

Insert the kneepad side support assembly into the base slots and then insert the seat assembly into the kneepad and side support assembly.



6

Use the remaining 4 carriage bolt assemblies to securely fasten the two sub assemblies to the base unit. All of the square shoulders of the bolts should be on the inside and the washers and lock nuts on the outside. (A1 + A4 +A5 +A6)

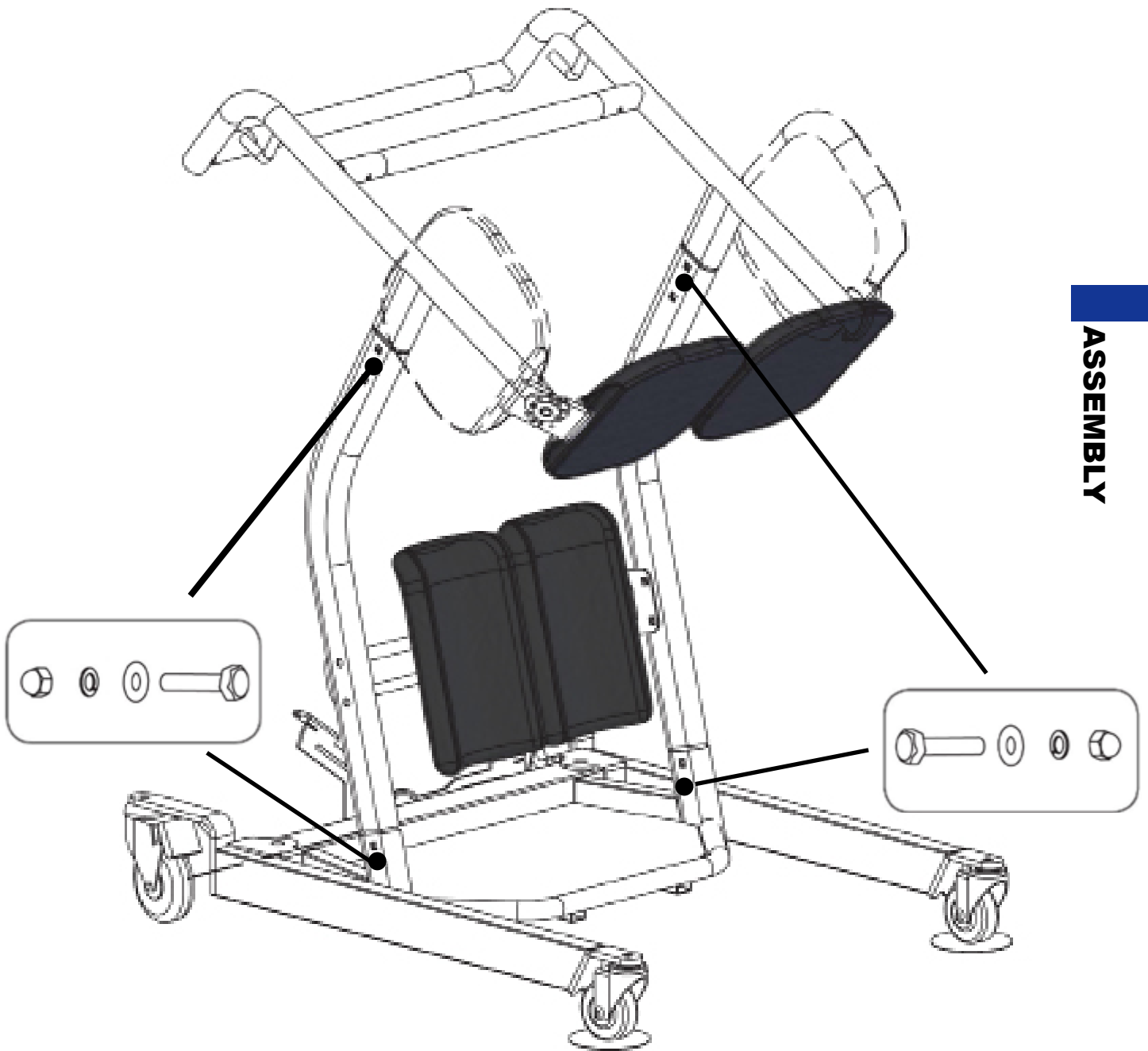

# OPERATING INSTRUCTIONS



Double check all assemblies for tightness and read operating instructions carefully prior to use.



## SEAT USAGE INSTRUCTIONS

The two black molded seat units can be rotated upwards to allow for patient loading. Once the patient is in an upward standing position the split seats must be lowered down to form a complete two-sided seat. Always make sure each of the two seat components are properly lowered forming a complete seat prior to having the patient sit down.

### STEP 1

Raise the two split seat units up and parallel to the side of the Protekt® Dash as shown below.

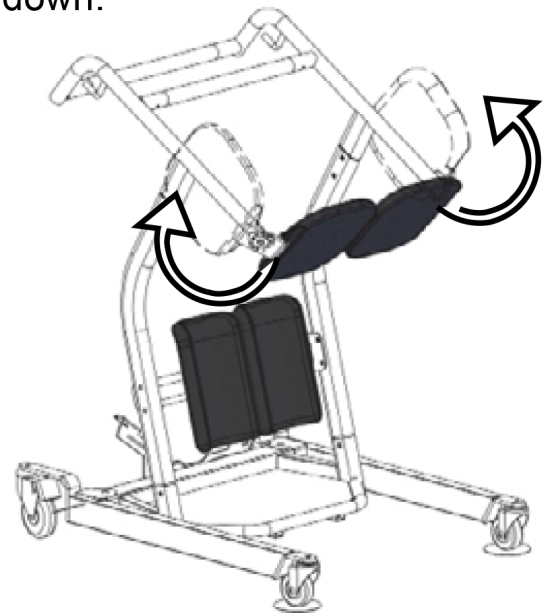

### STEP 2

Have the patient positioned at the edge of the surface and move the standing transfer aid in front of the patient so that their feet are firmly on the platform and knees/shins are in contact with the two cupped knee/shin pads as shown below. The Protekt® Dash allows access around wider obstacles such as recliners. The base opens by stepping on the foot pedal.





**STEP 3**

Lock the casters by stepping on the caster clip and pushing down as shown below.

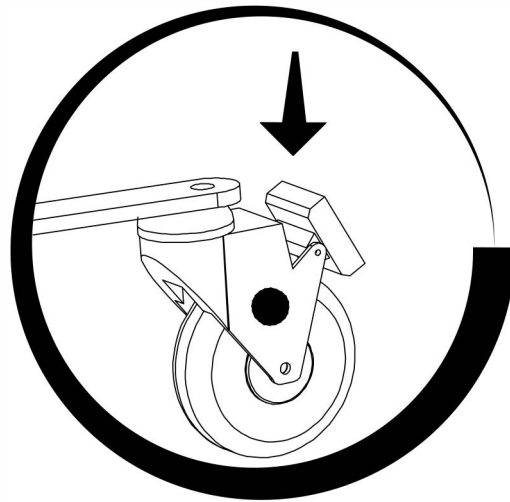

**STEP 4**

Have the patient grasp the cross bar closest to them and using their own strength pull themselves up into a standing position firmly on the platform as shown.



**STEP 5**

Lower both of the split seat units down into position to form a complete seat as shown.



**OPERATING  
INSTRUCTIONS**

## STEP 6

Have the patient lower themselves down onto the seat while keeping their knees/shins in the knee/shin pads and while still holding the cross bar with both hands as shown.



## STEP 7

Unlock the casters and place both hands on the cross bar furthest from the patient and move the standing transfer aid to the new surface. Make sure the patient is secure and in proper position as described in Step 6 above prior and during transfer as shown below.





# MAINTENANCE & INSPECTION

- The Protekt® Dash standing transfer is a manual unit and therefore requires minimal maintenance on an ongoing basis. However, to insure safety and proper use, the following steps should be taken on a monthly basis.
- Check all bolt/nut assemblies to make sure they are tight and no wear and tear is evident. Replace and tighten any worn assemblies prior to using the Protekt® Dash.
- Check the two seat assemblies to make sure they are not worn or damaged and that the bolts are tight. Replace any worn or damaged seat components before using the Protekt® Dash.
- Check the casters to make sure they are in working order and are secured firmly to the Protekt® Dash. Replace any worn or damaged casters prior to using the Protekt® Dash.

# ACCESSORIES

The Protekt® Dash standing transfer is designed to fully support a seated patient for transport. For patients requiring some upper body support or additional security a safety belt may be used. The 30669B Support Strap is designed to work with the Protekt® Dash.

See the pictures below for the use of this support strap:



Seat Lock

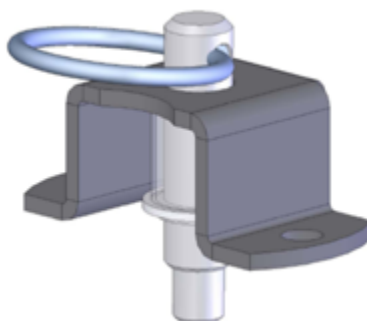

## WARRANTY AND RETURN GOODS POLICY

The Protekt® Dash you purchased is guaranteed to be free from defects in material and workmanship under normal use and service. The warranty period for this product is 3 Years on Frame from the date of purchase by the original purchaser. This warranty shall be voided upon transfer of ownership of this product. Proactive agrees to repair or replace this product at our discretion and at no charge, within the warranty period provided and that Proactive consents the unit is defective. The repaired or replacement unit shall be warranted for a period equal to the balance of the defective unit's warranty period.

### NOTE:

To ensure the best service to our customers, Proactive requires the following information to be included with the returned unit:

1. Model Name/Number and Serial Number (or Lot #) on the packaging.
2. Proof of purchase, i.e. a copy of the original invoice.
3. A Return Authorization number (RA#) obtained by calling an authorized dealer/distributor prior to the return of the product. The RA# must be clearly indicated on the outside of the packaging.
4. A detailed description of the problem and its symptoms on a note.

This warranty shall not apply to any product which has been repaired or altered in any way so as, in our judgment, to affect its functionality and durability, nor to any product subject to abuse, misuse, negligence or accident, improper maintenance, improper installation, nor to any product used with other parts, components and/or accessories with quality and/or specifications not compatible with this product. This warranty does not cover products that have been impaired by occurrences considered Acts of God over which authorized dealer has no control. This warranty shall also be voided if any required periodic maintenance, if applicable, has not been properly performed on this product.

This warranty and the aforementioned remedies presented are exclusive and in lieu of all other express or implied warranties. No other representations or claims shall be binding or obligate authorized dealer in any way. Any warranty applicable to this product is limited to the aforementioned period indicated. In no event shall authorized dealer be liable for any special, incidental, or consequential damages; loss of revenue; or cost of replacement goods; resulting from the use or malfunction of this product to the associated equipment on which and with which it is used. This warranty gives specific legal rights and you may be entitled to other rights that vary from state to state.



270 Washington Street,  
Mount Vernon, NY 10553  
Tel: 855-237-7622

[www.proactivemedical.com](http://www.proactivemedical.com)