



AURA PORTANEB

OPERATION MANUAL



**READ THIS MANUAL COMPLETELY AND CAREFULLY
BEFORE USING THIS PRODUCT**

Keep this manual for future reference

INDICATION FOR USE

The Mesh Nebulizer model NB40 is an ultrasonic (vibrating mesh) nebulizer system designed to aerosolize medications for inhalation by the patient.

The device may be used by adult patients and pediatric patients at the discretion of their physician at home, hospital & sub-acute care setting.

WARNING: U.S. Federal Law restricts this device to sale by or on the order of a licensed physician. Do not use unless prescribed by a licensed physician and with the prescribed medication only. Follow the physician's instructions for use at all times.

1 IMPORTANT SAFETY NOTES

SIGNS AND SYMBOLS

The following signs and symbols appear in this manual.

Read and understand this entire manual completely and carefully before using this product. Follow all safety instructions and warnings to avoid hazardous situation.



DANGER

DANGER indicates a hazardous situation which, if not avoided, will result in death or serious injury.



WARNING

WARNING indicates a hazardous situation which, if not avoided, could result in death or serious injury.



CAUTION

CAUTION indicates a hazardous situation which, if not avoided, may result in minor or moderate injury.



NOTICE

NOTICE addresses practices not related to personal injury, such as product and/or property damage.



DANGER

- Do not place or store product where it can fall or be pulled into a bathtub, sink, water, or other liquid. Risk of electric shock.
- Do not use this product while bathing, showering, washing dishes, or close to water sources of any kind. Risk of electric shock.
- Do not place device in water or drop into water or other liquid. Do not allow water to be sprayed onto the unit. The unit must be operated only when it is completely dry. Risk of electric shock.
- Do not reach for a product that has fallen into water or other liquid. If possible, safely unplug immediately. Do not touch a wet supply cable or plug. Do not touch the supply cable or plug with wet extremities.
- Never touch the unit, including the AC adapter, with wet hands while it is plugged in. This can cause an electric shock.

- Before use, ensure that there is no visible damage to the unit or accessories. Never operate the unit if it:
 - has any damaged parts, e.g. damaged cord, plug or housing
 - has been exposed to extreme humidity or to any liquids inside the housing
 - has been dropped
 - is not working properly
- If the unit does not function correctly or if you notice any abnormalities, e.g. an unusual noise or smell, stop using the unit immediately. Switch off and unplug the unit immediately. When in doubt, do not use the unit and contact the authorized distributor.
- A product should never be left unattended when plugged in.









WARNING

- U.S. Federal Law restricts this device to be sold by or on the order of a licensed physician. Do not use unless prescribed by a licensed physician and with the prescribed medication only. Follow the physician's instructions for use at all times.
 - Using the unit is not a substitute for consultation with or treatment from a physician. Whenever you have any pain, illness or discomfort, always contact your physician first. If you have an emergency, call 911 immediately.
 - In the case of oversensitivity of the bronchial system, medicines containing essential oils can sometimes cause acute bronchospasm (a sudden, cramp-like tightening of the bronchi accompanied by breathlessness). In case of an emergency, call 911 immediately.
 - If you start feeling any discomfort, pain, drowsiness or other change in your condition, stop using the unit immediately. For medical advice please contact a licensed physician. If you have an emergency, call 911 immediately.
 - This device is not intended to be used by persons with restricted physical (e.g. activity limitations, disabilities), sensory (e.g. insensitivity to pain) or mental abilities (e.g. mental disorders) or persons lacking of the required experience or knowledge for a safe operation of the device, unless closely supervised by a person responsible for their safety. **NEVER LEAVE THOSE WHO REQUIRE CLOSE SUPERVISION UNATTENDED WITH THIS DEVICE.**
 - This product contains small parts that may present a choking hazard to children. Keep all small parts out of reach of children. The power cord also presents a strangulation hazard. **NEVER LEAVE CHILDREN OR THOSE WHO REQUIRE CLOSE SUPERVISION UNATTENDED WITH THIS DEVICE.**
- Use the unit only on human being and for its intended purpose (aerosol inhalation) and in the manner described in these instructions for use. Any improper use can be dangerous!

- Do not operate the unit in the presence of flammable gases, oxygen and aerosol spray products. Non-compliance may result in e.g. fire, burns, explosions, etc.
- Single patient use only: For hygienic reasons, each user must use his own accessories to avoid the risk of infections and communication of diseases.
- During use, hold the unit away from the eyes as some nebulized medicines may cause damage to the eyes.
- Do not use this unit while driving a vehicle.
- Never use while sleeping or feeling drowsy.
- Do not administer treatment to a sleeping person, because not enough medicine will reach the lungs.
- Portable and mobile RF communication devices can disrupt electrical medical equipment. Technical electromagnetic compatibility data is available on request from the authorized distributor.
- This unit is not intended for commercial or clinical use, but only for individual, private household use! Do not allow others to use it.
- Essential oils, cough medicines, solutions designed for gargling, and drops for application to the skin or for use in steam baths are wholly unsuitable for inhalation using a nebulizer. These substances are often highly viscous and can impair the correct function of the device and hence affect the effectiveness of its application in the long term.

The following symbols are used on the packaging and on the nameplate of the device and accessories.

	Type BF applied
	Follow instructions for use
	Manufacturer
	On/Off
SN	Serial number
	Device in protection class 2
	Do not use outdoors
IP22	Protected against foreign objects equal to or greater than 12.5 mm in diameter and against drops of water falling at up to 15° from vertical



NOTICE

- If the medicine tank is empty, do not attempt to operate the unit.

CONTENTS

1. Important safety notes



DANGER



WARNING



CAUTION



NOTICE

2. Getting acquainted
3. Important information on the device
4. Description of device and accessories
5. Initial use
6. Operation
7. Cleaning
8. Storage and care for the device
9. Disposal
10. Troubleshooting
11. FCC Statement
12. Technical specifications
13. Warranty and Service

KEEP THIS MANUAL FOR FUTURE REFERENCE

If the instruction manual is damaged or if you no longer have the instruction manual in your possession, please download one from our website: www.aura-medical.com/support

The manufacturer shall not be held liable for damage or injuries caused by improper or incorrect use.

2 GETTING ACQUAINTED

Dear Valued Customer,

Thank you for purchasing our Aura NB40 Portable Nebulizer. To operate the device properly and to achieve the best results, please read the instruction manual thoroughly and keep it so that you can refer back to it if needed.

AREA OF APPLICATION

The Aura Portable Nebulizer is an ultrasonic (vibrating mesh) nebulizer system designed to aerosolize medications for inhalation by the patient. The device may be used by both adult and pediatric patients and is suitable for use at home.

The nebulization and inhalation of medication prescribed or recommended by a doctor can prevent against diseases of the respiratory tract, treat the side effects of these disorders and accelerate healing. For more information on possible applications, consult your doctor or pharmacist. Medicines should only be inhaled when instructed by a doctor. Inhalation should be performed in a calm and relaxed atmosphere. Inhale slowly and deeply to enable the medicine to reach the bronchi and deep into the lungs. Exhale normally.

3 IMPORTANT INFORMATION ON THE DEVICE

3.1 ACCESSORIES



WARNING

- The NB40 Nebulizer must only be used with suitable NB40 accessories. The use of other accessories may damage the device and can impair treatment efficiency.

3.2 PROTECTING AGAINST LEAKS



NOTICE

- Do not overfill the medicine container. The recommended filling amount is between 2 ml. to 10 ml.

When filling the medicine tank with medicine, ensure that you do not exceed the maximum mark (10 ml). The recommended filling amount is between 2 and 10 ml. During use, you can tilt the device up to a maximum angle of 45° in any direction, without impairing its nebulizing function or success of the treatment. However, atomization only takes place if the medicine is in contact with the mesh. If it is not, nebulization stops automatically. If this happens, please try to hold the device as upright as possible.

3.3 SHUTTING THE DEVICE OFF AFTER USE



NOTICE

- When the medication cup is empty please shut off the device to avoid damaging the mesh or internal elements.

4 DESCRIPTION OF DEVICE AND ACCESSORIES

OVERVIEW OF NEBULIZER

1. Nebulizer main unit
2. Medicine tank
3. Mesh transducer module
4. Electrode contact
5. Power On/ Off button
6. Battery cover
7. Power DC jack socket
8. Led indicator for displaying the operating status

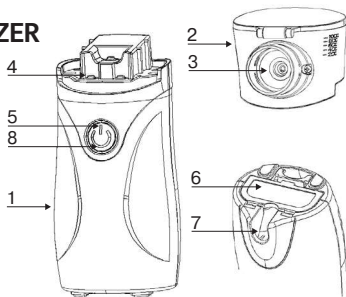

OVERVIEW OF NEBULIZER

9. Large Mask (Applied parts)
10. Small Mask (Applied parts)
11. Mask connector
12. Mouthpiece (Applied parts)
13. Alkaline AA battery X 2
14. AC adapter

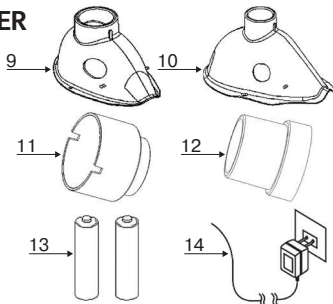



WARNING

- Packaging materials are a deadly hazard for children and can cause suffocation. Remove all packaging materials immediately and keep them away from children at all times.
- To reduce the risk of increased bacterial growth, infection, illness, injury from contamination or other health risks, always follow all hygiene instructions, see Section 7 Cleaning, when using this unit. Unplug the unit before cleaning the unit.
- Do not use the unit outside the specified ambient conditions. See Sections 8 Storage and Care for the Device and 12 Technical Specifications for details.

USING THE DEVICE FOR THE FIRST TIME

Before first use, the nebulizer and the accessories should be cleaned.

Refer to Section 7 Cleaning for instructions.

Before use, ensure the device and accessories are at room temperature.

5.1 ASSEMBLING THE MEDICINE TANK TO NEBULIZER MAIN UNIT:

Remove the device from the packaging.

Connect the medicine tank to the nebulizer main unit. Make sure to connect firmly so that you hear a “click” sound. Refer to Fig. 1.

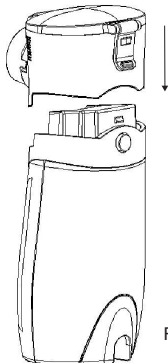

Fig. 1

Note:

To remove the medicine tank from nebulizer main unit, press the button (Refer to Fig.2) and pull upward.

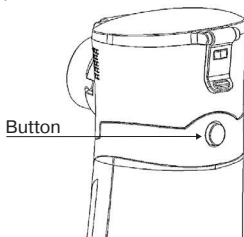

Fig. 2

5.2 OPERATING THE DEVICE WITH BATTERIES/ INSERTING BATTERIES:



WARNING

- Swallowing batteries and/or battery fluid can be extremely dangerous. Keep the batteries and unit out of the reach of children and disabled persons. Should any person swallow a battery and/or battery fluid, call 911 immediately.
- Should battery fluid leak and come into contact with your eyes or skin, rinse with plenty of clean water immediately. Call 911 immediately.
- Batteries should not be charged or reactivated by any other means.
- Batteries should not be taken apart, thrown into the fire or short circuited.



CAUTION

- In case of a battery fluid leakage, do not touch the battery fluid. Avoid skin contact (e.g. put on protective gloves) and clean the battery compartment with a dry cloth.



NOTICE

- Always use the size and type of batteries indicated.

- Never use different types of batteries, battery brands or batteries with different capacities.
- Always replace all batteries at the same time.
- Leaking batteries may damage the device. If you do not intend to use the unit for a long period of time, remove the batteries from the battery compartment before placing the device in storage.
- When changing batteries, ensure that the medicine container is completely empty, otherwise there is a risk of leaks.
- Batteries can contain toxins that are harmful to the environment. Always dispose of batteries in accordance with applicable local regulations. Do not dispose of batteries with normal household waste.

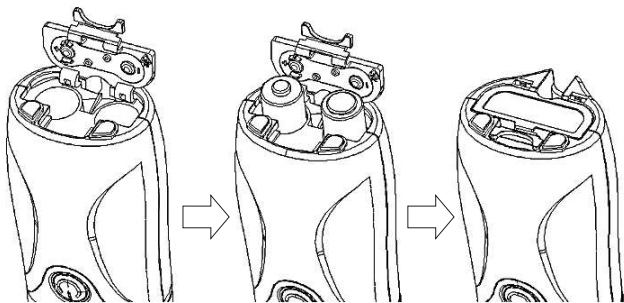

Fig. 3

- To open the battery cover on the underside of the device, apply light pressure and pull the battery lid up.
- Insert two batteries (type AA LR6)
- Ensure that the poles of the batteries are touching their respective poles in the device (Fig 3)
- Press the battery cover lid down.

Note:

When changing batteries, ensure that the medicine container is completely empty.

When the LEDs light up orange, you should replace the batteries.

You can operate the device for approx. 100 minutes with new alkaline batteries.

This is sufficient for 5-8 uses of saline liquid



DANGER

- Do not use any AC Adapter other than the one supplied with the unit.
- When using the AC Adapter, take precaution of all warnings and safety information in order to avoid hazardous situations.
- Never touch the unit, including the AC Adapter with wet hands while it is plugged in. This can cause an electric shock.
- Do not pull the AC Adapter from the power outlet by the cord. Always grasp the AC Adapter body and unplug it. Failure to do so could result in risk of electric shock, short circuiting, or fire.
- Do not pinch or bend the power cord or pull it over sharp objects. This can cause an electric shock.
- The unit and the AC Adapter must be protected and stored away from sources of heat. (e.g. stoves, heating radiators).
- The AC Adapter has a polarized plug (one blade is wider than the other). As a safety feature, this plug will fit into a polarized outlet only one way. If the plug does not fit fully into the outlet, reverse the plug. If it still does not fit, contact a qualified electrician. Do not modify the plug in any way. Do not attempt to manipulate with this safety feature.
- Do not operate this device outdoors when using the AC Adapter. Risk of electric shock.
- Do not use extension cords, multi-sockets and/or voltage converters when using the AC Adapter.
- Always unplug this product immediately after use and make sure it is not accessible to children.
- A product should never be left unattended when plugged in.



WARNING

- Before using the AC Adapter, always check the data plate on the bottom of the NB40 Portable Nebulizer to ensure that the voltage and current indicated on the unit correspond to the voltage and current available.
- Lay the power cord in such a way that no one can trip over it. There is a danger of injury due to e.g. stumbling, tripping, and falling down.
- Connect the AC adaptor only to the mains voltage listed on the type plate.
- Insert the AC adaptor connector into the connector socket on the unit, and the AC adaptor fully into a suitable wall socket.

Note:

- Ensure that there is a socket near to where the device will be used. Use the mains cable in a way that no one can trip over it.
- To disconnect the nebulizer from the mains after use, first switch off the device and then remove the AC adaptor from the socket
- The AC adaptor cannot be used for charging batteries.

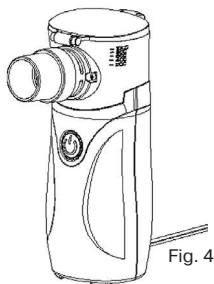

6 OPERATION

DANGER

- Before use, ensure that there is no visible damage to the unit or accessories. Never operate the unit if it:
 - has any damaged parts, e.g. damaged cord, plug or housing
 - has been exposed to extreme humidity or to any liquids inside the housing
 - has been dropped,
 - is not working properly

WARNING

- Always follow your physician's instructions regarding the type of medicine to be used, the dosage, frequency, and duration of inhalation. Any improper use may cause hazardous situations.
- Do not use medicine powder with liquid in this device. The Mesh transducer module warranty excludes damage due to improper use causing powder block on mesh hole.

- Do not use medicine with viscosity higher than 3 in this device. Mesh transducer module warranty excludes damage due to incorrect or inappropriate medicine viscosity used.
- Apart from the prescribed medication, use only distilled water or a saline solution with the unit. Other liquids may cause health problems. Always consult your physician to determine what will be suitable for you. Furthermore, other liquids may damage the mesh nebulizer and accessories. When there is medicine inside the medicine tank, do not shake nebulizer with force or put it through strong impact. Doing so may cause liquid leakage into internal PCB and damage the device.
- No liquid operation protection: NB40 is equipped with dual protection technology to protect against ULTRASONIC transducer damage.
- If there is no medicine in the medicine tank, the ultrasonic transducer will stop operating.
- If there is almost no medicine in the medicine tank, and residue of medicine causes air bubbles, you can turn off the device manually.
- If several different medicines are to be inhaled in succession, the medicine tank and accessories must be cleaned after each use before using a different medication. For more information, see Section 7 Cleaning.
- Tilt operation range: Comparing with other similar nebulizers products which can only operate very stable with vertical angle (90 degrees), the NB40 can be used within 45 degree tilt angle. However, the nebulization will cease if the tilt exceeds 45 degrees.
- To reduce the risk of increased bacterial growth, infection, illness, injury from contamination or other health risks always follow all hygiene instructions, see Section 7 Cleaning, when using this unit. Unplug the unit before cleaning the unit.
- Check the Portable Nebulizer and all accessories before each use. Dirty, damaged and/or worn parts may diminish or eliminate the effectiveness of treatment. Replace damaged and/or worn parts. Dirty parts must be cleaned following all hygiene instructions. See Section 7 Cleaning.
- Do not use the unit outside the specified ambient conditions. See Sections 8 Storage and Care for the Device and 12 Technical Specifications for details.

Note:

Before use, ensure the device and accessories are at room temperature.

6.1 Preparing the nebulizer

- For hygienic reasons, it is imperative that the nebulizer and accompanying accessories are cleaned after every use. If the treatment requires that various different medicines be inhaled one after another, ensure that the medicine tank is cleaned after every use. For details, see Section 7 Cleaning.

6.2 Filling the nebulizer

- Open the medicine tank by lifting the hook. (Refer to Fig.5, 6)
- Fill the medication into the medicine tank. (Refer to Fig. 7)
- Close the medicine tank by pressing the hook firmly and securely back to place. (Refer to Fig. 8)



Fig. 5



Fig. 6

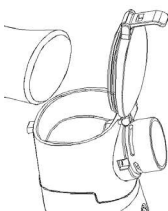

Fig. 7



Fig. 8

6.3 Inhalation with the mouthpiece

- Connect mouthpiece to the medicine tank opening (Refer to Fig. 9)
- Sit upright and hold the device as upright as possible, do not tilt the device more than 45 degrees in any direction.
- Enclose the mouthpiece completely with your lips.
- Press On/ Off button. There will be blue LED light on On/ Off button.

Note:

At any time during a treatment, you can turn off the device by pressing On/ Off button.

- Breathe in slowly and deeply through your mouth and out through your nose.
- Once the medicine is nebulized completely, manually shut off the device.

Note:

Residue of medicine may remain inside the mouthpiece due to vapor accumulation.

- Disinfect and clean the device immediately after each use.

Note:

To prolong the mesh component life, allow at least 1 hour interval between each treatment.

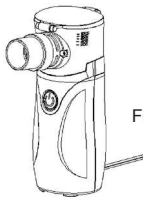

Fig. 9

6.4 Inhalation with the mask

- Connect mask connector to the medicine tank opening, then connect mask to the mask connector. (Refer to Fig. 10, 11)
- Sit upright and hold the device as upright as possible, do not tilt the device more than 45 degrees in any direction.
- Put the mask connector between chamber and mask.
- Press On/ Off button. The LED will light up blue when On.

Note:

At any time during treatment, you can turn off the device by pressing On/ Off button.

- Breathe slowly and deeply in and out through your nose.
- Once the medicine is nebulized completely, shut off the device manually.

Note:

Residue of the medicine may remain inside the mask connector due to vapor accumulation.

- Disinfect and clean the device immediately after each use.

Note:

To prolong the mesh component life, allow at least 1 hour interval between each treatment.

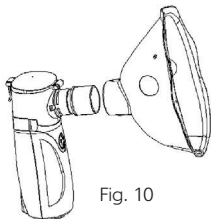

Fig. 10

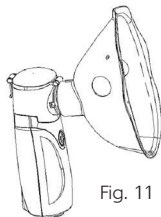

Fig. 11

Note:

You can collect the residue of medicine inside mask tube and put it back to medicine tank to vaporize again. (Refer to Fig. 12)

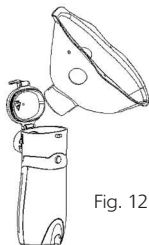

Fig. 12

7 CLEANING



DANGER

- Before you clean the unit, always switch it off, unplug it and let it cool off.



WARNING

- To reduce the risk of increased bacterial growth, infection, illness, injury from contamination or other health risks, always follow all hygienic instructions when using this unit. Unplug the unit before cleaning the unit.
- For hygienic reasons, the medicine tank with mesh transducer module and the accessories mouthpiece, mask connector, masks (not AC Adapter) must be cleaned after each treatment and prior to initial operation.
- Ensure that all parts are thoroughly dried after every cleaning. Residual moisture or water droplets can result in an increased risk of bacterial growth and therefore represent a risk for your health.
- If several different medicines are to be inhaled in succession, the medicine tank and accessories must be cleaned after each use before using a different medication.
- The medicine tank with the mesh transducer module and accessories must not be mechanically cleaned with brushes or the like as this can cause irreparable damage and may render the treatment ineffective.
- For additional requirements regarding the necessary hygienic preparations

(hand washing, handling of medicines or inhalation solutions) in high-risk groups (e.g. cystic fibrosis patients), contact your physician.

- When cleaning, ensure that all residues are removed. Never use any substances that may be poisonous upon contact with the skin or mucous membranes, or when swallowed or inhaled. When in doubt, contact your physician for advice.



NOTICE

- Ensure that no water penetrates inside the nebulizer main unit! Never immerse the nebulizer main unit in water or any other liquid. Never hold the nebulizer main unit under running water to clean it. Otherwise liquid can enter the nebulizer main unit and cause damage.
- While cleaning, ensure that that you do not touch the plastic mesh hole (in the mesh transducer module) with your fingers or any other objects, as this may destroy it. The mesh outlet (in the mesh transducer module) must not be rinsed under running water, otherwise the mesh may be damaged.
- Do not put the device or accessories in a dishwasher, washing machine or tumble dryer.
- Do not use any aggressive solvents, cleaning agents, detergents or any other strong chemicals to clean the device.

7.1 Cleaning and Drying

The nebulizer and accessories are intended for multiple uses.

Before you clean the device, always switch it off, unplug it and let it cool off.

7.1 Cleaning and Drying

The Aura Portable Nebulizer and the accessories used (mouthpiece, masks, mask connector) must be cleaned with diluted soap water after each use.

Cleaning the medicine tank and mesh holes:

1. Open the cover of the medicine tank and discard the remaining medication.
2. Rinse the medicine tank with water.
3. Make a solution of 1 part white vinegar to 2 parts water. Pour into the medicine tank and let it sit for 5 minutes.

4. Turn on the device and allow the solution to nebulize for 2 minutes.
5. Discard the vinegar solution. Add 4 cc's of water and nebulize for 2 minutes.
6. Power off the device and discard remaining water.
7. Allow to air dry completely for 4-6 or overnight.

Cleaning the accessories:

1. Clean the accessories (mouthpiece, masks, mask connector) with diluted soap water and rinse.
2. Allow to air dry completely before packing away.

Cleaning the nebulizer main unit:

Clean the outside of the nebulizer main unit with a cotton cloth dampened with water.

Do not allow water to enter the device.

Cleaning the nebulizer main unit:

Clean the outside of the nebulizer main unit with a cotton cloth dampened with water.

Do not allow water to enter the device.

Cleaning the 5 stainless steel poles:

Use a cotton swab dampened with water to clean the 5 stainless steel poles contact on the nebulizer main unit (3 poles) and underneath the mesh transducer module (2 poles).

7.1.2 Drying

Place all the accessories on a dry, clean and absorbent surface and allow them to dry completely.

Once all accessories are completely dry, store them in a dry and sealed container.

7.2 Material resistance

As with all plastic components, frequent use and cleaning of the accessories can lead to a certain amount of wear. Over time, this can alter the nebulization properties and may eventually affect the efficiency of treatment. It is therefore recommended that the mesh transducer module (medicine tank) be replaced at least once a year. In case of frequent use, replacement may be necessary earlier.

Note:

This cleaning procedure has been done and tested. The test conducted 30 treatments and cleaning cycles. Each treatment and cleaning cycle consisted of placing an albuterol sample into the Portable Nebulizer, nebulizing it to the end. After nebulizing, cleaning and drying the mesh transducer module, medicine tank and accessories according to cleaning/ drying instructions mentioned above.

Conclusion:

After the test was conducted, the nebulization performance of the nebulizer showed no change in any parameters measured. It is concluded that the cleaning procedure as described in the cleaning section above is effective and safe. Visual inspection of the samples after exposure showed no degradation, damage or cracks.

8 STORAGE AND CARE FOR THE DEVICE



DANGER

- Always unplug this product immediately after use and make sure it is not accessible to children.
- Do not open or disassemble the nebulizer. Risk of electric shock. All disassembly and maintenance of the device must be performed by a qualified service technician. If you need to have the unit repaired, please contact the authorized distributor.
- The unit and the AC Adapter must be protected and stored away from sources of heat. (e.g. stoves, heating radiators)



WARNING

- Avoid using the device in high electromagnetic environment.
- Always keep the device out of reach of children.



NOTICE

- Protect the unit and the parts from strong impacts such as dropping the

unit on the floor.

- Do not leave medication inside the medicine container when not in use.
- Never open or attempt to repair the unit yourself. Failure to observe this shall void the warranty.
- Store the device and accessories in a location protected against environmental influences, i.e. in a safe and dry location. Do not expose the device and accessories to direct sunlight, extreme hot or cold temperatures or humidity (e.g. in the bathroom). The device and accessories must be stored in the specified ambient conditions. See Section 12 Technical Specifications for details.
- Protect the unit against dust, dirt and moisture. This may damage the device.
- Leaking batteries may damage the device. If you do not intend to use the unit for a long period of time, remove the batteries from the battery compartment before placing the device in storage.
- Store the device and accessories in a safe and dry location. Store and transport the nebulizer away from direct sunlight.

9 DISPOSAL



NOTICE

- Batteries can contain toxins that are harmful to the environment. Always dispose the batteries in accordance with applicable local regulations. Do not dispose of batteries with normal household waste.
- Dispose of the device, components and optional accessories according to applicable local regulations. Unlawful disposal may cause environmental pollution.
- If you have any questions, please contact the local authorities responsible for waste disposal.

10 TROUBLESHOOTING

Problem/ Question- Possible Cause/ Remedy

A. The nebulizer produces little or no aerosol. Output is too low.

1. Too little medicine in the nebulizer.
2. The nebulizer is not held in an upright position.
3. The medicine is unsuitable for nebulization (e.g. Too thick, viscosity is more

than 3). The medicine should be specified by the doctor.

4. The batteries are almost flat. Please change batteries.
5. There may be air bubbles inside the medicine tank which are preventing the medicine from coming in contact with the mesh. Please check and remove bubbles.
6. Mesh holes may be blocked by unknown particles, the vapor cannot pass through the mesh.

To test: Put 6 ml. of water inside the medicine tank and nebulize, if nebulization time takes longer than 30 minutes, then the mesh holes are blocked.

Solution A: To clean mesh holes and unclog the blocked particles, put a solution of 1 tsp of vinegar + 6 ml. of water into the medicine tank, let the solution nebulize completely. Afterwards, clean and disinfect the device thoroughly before using it for treatment. Refer to Section 7 Cleaning.

Solution B: Reverse clean operation:

b.1 To start the reverse clean mode: Press and hold the Power On/ Off button (around 5 seconds) until you see a purple light flash once from the Power On/Off button.

b.2 After the purple light flashed once, the Power On/ Off button light will change to blue.

b.3 Put 2 ml. of water into the mesh outlet (refer to the picture Fig.13). The water will be nebulized from mesh outlet to the medicine tank. This may take several minutes to complete. You will hear a sound while it is running. When the reverse clean is complete, the nebulizer will reverse back to regular mode and nebulize for a few seconds.

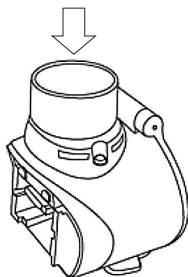

Fig. 13

b.4 After the water is nebulized completely into the medicine tank, turn off the device manually by pressing Power On/Off button.

7. If problem persists after checking all possible causes, please contact the authorized distributor to replace the mesh transducer module.

RE-START INSTALLATION INSTRUCTIONS FOR NB40 MESH TRANSDUCER MODULE

Whenever you are to use a new mesh transducer module, a “mesh transducer module re-start installation” process should be performed.

- a. Put 2 ml. of water into the medicine tank.
- b. Press and hold Power On/ Off button for about 10 seconds. You will see an orange light flash 2 times, once on the 5th second and once on the 10th second.
- c. Let the device vapor out the 2 ml. of water completely.
- d. Mesh transducer module “re-start installation” process is now finished.
- e. Your Portable Nebulizer device is now ready for use.

B. Which medicines are suitable for inhalation?

Only your doctor can advise you which medicine to use to treat your condition. Consult your doctor. With this unit, you can nebulize and medication with a viscosity of less than 3.

C Some inhalation solution remains in the nebulizer. This is normal. Stop inhaling as soon as you hear a marked difference in the sound made by the nebulizer, or when the device switches off automatically due to insufficient inhalant.

D. What special steps should be taken for babies and children?

1. For babies, the mask should cover the mouth and nose to guarantee effective inhalation.
2. For children, the mask should also cover the mouth and nose.
3. Do not administer treatment to a sleeping person, because not enough medicine will reach the lungs.

Note: Children should only use the device with the help and under supervision of an adult. Never leave a child alone with a nebulizer.

E. Inhalation with mask takes longer.

This is normal. Less medicine is inhaled per breath through the mask than when using the mouthpiece. The aerosol is mixed with ambient air through the holes in the mask.

F. Does each person need to use their own accessories? This is absolutely necessary for hygiene reasons.

11 FCC STATEMENT

This device complies with Part 15 of the FCC Rules. Operation is subject to the following two conditions: (1) this device may not cause harmful interference, and (2) this device must accept any interference received, including interference that may cause undesired operation”

Note:

This equipment has been tested and found to comply with the limits for a Class B digital device, pursuant to Part 15 of the FCC Rules. These limits are designed to provide reasonable protection against harmful interference in a residential installation. This equipment generates uses and can radiate radio frequency energy and, if not installed and used in accordance with the instructions, may cause harmful interference to radio communications. However, there is no guarantee that interference will not occur in a particular installation. If this equipment does cause harmful interference to radio or television reception which can be determined by turning the equipment off and on, the user is encouraged to try to correct the interference by one or more of the following measures:

- Reorient or relocate the receiving antenna.
- Increase the separation between the equipment and receiver.
- Connect the equipment into an outlet on a circuit different from that to which the receiver is connected.
- Consult the dealer or an experienced radio/TV technician for help.



CAUTION

Any changes or modifications not expressly approved by the manufacturer of this product and the party responsible for compliance could void the user's authority to operate the equipment.

12 TECHNICAL SPECIFICATIONS

Dimensions (LxWxH)	52.5 x 52 x 126 mm
Device weight	110 g excluding batteries
Battery operation	2 x 1.5 V type AA Alkaline battery (LR6)
Medicine tank capacity	2 ml to 10 ml
Atomization rate approx	0.25 ml/min
Oscillation frequency	100 kHz
Mains connection	100-240 V ~, 50-60 Hz; 0,15 A
Operating conditions	Temperature: 41° ~ 104°F (5°C ~ 40°C) Humidity: 15%-93% R.H. non-condensing
Storage and transport conditions	Temperature: -77° ~ 158°F (-25°C ~ +70°C) Humidity: < 93% R.H. non-condensing
Atmosphere pressure	700hPa~1060hPa

IP 22 Degrees of protection against ingress of water and access to hazardous parts.

Note:

This device may not be used while in transport (car, train, emergency vehicle)

All Models NB40, NE105 and K132247 operate with the same PCBA, circuit, and software control. They are only different in appearance. They are substantially equivalent. Please refer to the performance summary data of NE105 and K132247.

PERFORMANCE SUMMARY DATA

		Albuterol Sulfate (2.5 mg/3.0 ml)	Ipratropium Bromide (0.5 mg/2.5 ml)	Cromolyn Sodium (20 mg/2.0 ml)
Particle Size (MMAD)	(microns)	1.98 -2.5	1.69 -2.29	1.72 -2.32
Geometric Standard Deviation (GSD)		2.19 -2.55	2.07 -2.68	2.38 -2.61
Total Dose	(delivered)	1,438 – 1,743	272 - 380	9,655 – 12,141
Respirable Dose (0.5-5 μ m)	(delivered)	947 – 1,098	169 - 227	6,795 – 8,244
Coarse Particle Dose (>4.7 μ m)	(μ g)	428 - 656	88 - 148	2,252 – 3,650
Fine Particle Dose (<4.7 μ m)	(μ g)	972 – 1,125	177 - 238	7,197 – 8,697
Ultra-Fine Particle Dose (<1.0 μ m)	(μ g)	203 - 273	36 - 73	1,692 – 2,744

Table shows a summary of the measured performance data that indicates confidence intervals corresponding to a 95% confidence level for all combined data.

Protocol 13-0028

PIPER MEDICAL PROTOCOL:

In tra-Sample and Inter-Sample Dose and Particle Size Variability Testing of the Ultrasonic Portable Nebulizer Model NE105

ELECTROMAGNETIC COMPATIBILITY

- The device complies with current specifications with regard to electromagnetic compatibility and is suitable for use in all premises, including those designated for private residential purposes. The radio frequency emissions of the device are extremely low and in all probability.
- Do not cause any interference with other devices in the proximity.
- It is recommended that you do not place the device on top of or close to other electronic devices. Should you notice any interference with other electrical devices, move the device or connect it to a different socket.
- Radio equipment may affect the operation of this device.

ELECTROMAGNETIC COMPATIBILITY INFORMATION

Guidance and manufacturer's declaration – electromagnetic emissions		
The NB40 is intended for use in the electromagnetic environment specified below. The customer or the user of the NB40 should assure that it is used in such an environment.		
Emissions	Compliance	Electromagnetic environment-guidance
RF emissions CISPR 11	Group 1	The NB40 uses RF energy only for its internal function. Therefore, its RF emissions are very low and are not likely to cause any interference in nearby electronic equipment.
RF emissions CISPR 11	Class B	
Harmonic emissions IEC 61000-3-2	Class C	
Voltage fluctuations/ flicker emissions IEC 61000-3-3	Complies	

Guidance and manufacturer's declaration – electromagnetic immunity

The NB40 is intended for use in the electromagnetic environment specified below. The customer or the user of the NB40 should assure that it is used in such an environment.

Immunity test	IEC 60601 test level	Compliance level	Electromagnetic environment-guidance
Electrostatic discharge (ESD) IEC 61000-4-2	± 6 kV contact ± 8 kV air	± 6 kV contact ± 8 kV air	Floors should be wood, concrete or ceramic tile. If floors are covered with synthetic material, the relative humidity should be at least 30 %.
Electrical fast transient/burst IEC 61000-4-4	± 2 kV for power supply lines	± 2 kV for power supply lines	Mains power quality should be that of a typical commercial or hospital environment.
Surge IEC 61000-4-5	± 1 kV line(s) and neutral	± 1 kV line(s) and neutral	Mains power quality should be that of a typical commercial or hospital environment.
Voltage dips, short interruptions and voltage variations on power supply input lines IEC 61000-4-11	<5 % Ut (>95 % dip in Ut) for 0,5 cycle 40 % Ut (60 % dip in Ut) for 5 cycles 70 % Ut (30 % dip in Ut) for 25 cycles <5 % Ut (>95 % dip in Ut) for 5s	<5 % Ut (>95 % dip in Ut) for 0,5 cycle 40 % Ut (60 % dip in Ut) for 5 cycles 70 % Ut (30 % dip in Ut) for 25 cycles <5 % Ut (>95 % dip in Ut) for 5s	Mains power quality should be that of a typical commercial or hospital environment. If the user of the NB40 requires continued operation during power mains interruptions, it is recommended that the NB40 be powered from an uninterruptible power supply or a battery.
Power frequency (50/60 Hz) magnetic field IEC 61000-4-8	3 A/m	Not applicable	Not applicable

Note: Ut is the a.c. mains voltage prior to application of the test level

Guidance and manufacturer's declaration – electromagnetic immunity

The NB40 is intended for use in the electromagnetic environment specified below. The customer or the user of the NB40 should assure that it is used in such.

Immunity test	IEC 60601 test level	Compliance level	Electromagnetic environment-guidance
Conducted RF IEC 61000-4-6	± 6 kV contact ± 8 kV air	± 6 kV contact ± 8 kV air	<p>Portable and mobile RF communications equipment should be used no closer to any part of the NB40, including cables, than the recommended separation distance calculated from the equation applicable to the frequency of the transmitter.</p> <p>Recommended separation distance</p> $d = 1,2 \sqrt{P}$ <p>$d = 1,2 \sqrt{P}$ 80 MHz to 800 MHz</p> <p>$d = 1,2 \sqrt{P}$ 800 MHz to 2,5 MHz</p> <p>where P is the maximum output power rating of the transmitter in watts (W) according to the transmitter manufacturer and d is the recommended separation distance in metres (m).</p> <p>Field strengths from fixed RF transmitters, as determined by an electromagnetic site survey, should be less than the compliance level in each frequency range b. Interference may occur in the vicinity of equipment marked with the following symbol:</p> 
Radiated RF IEC 61000-4-3	3 V/m 80 MHz to 2.5 GHz	3 V/m	

Note 1: At 80 MHz and 800 MHz, the higher frequency range applies.

Note 2: These guidelines may not apply in all situations. Electromagnetic propagation is affected by absorption and reflection from structures, objects and people.

a. Field strengths from fixed transmitters, such as base stations for radio (cellular/cordless) telephones and land mobile radios, amateur radio, AM and FM radio broadcast and TV broadcast cannot be predicted theoretically with accuracy. To assess the electromagnetic environment due to fixed RF transmitters, an electromagnetic site survey should be considered. If the measured field strength in the location in which the NB40 is used exceeds the applicable RF compliance level above, the NB40 should be observed to verify normal operation. If abnormal performance is observed, additional measures may be necessary, such as re-orienting or relocating the NB40.

b. Over the frequency range 150 kHz to 80 MHz, field strengths should be less than 3 V/m.

Recommended separation distances between portable and mobile RF communications equipment and the NB40

The NB40 is intended for use in an electromagnetic environment in which radiated RF disturbances are controlled. The customer or the user of the NB40 help prevent electromagnetic interference by maintaining a minimum distance between portable and mobile RF communications equipment (transmitters) and the NB40 as recommended below, according to the maximum output power of the communications equipment.

Rated maximum output power of transmitter W	Separation distance according to frequency of transmitter m		
	150 kHz to 80 MHz <i>d = 1,2 √P</i>	80 MHz to 800 MHz <i>d = 1,2 √P</i>	800 MHz to 2.5 GHz <i>d = 1,2 √P</i>
0.01	0.12	0.12	0.23
0.1	0.38	0.38	0.73
1	1.2	1.2	2.3
10	3.8	3.8	7.3
100	12	12	23

For transmitters rated at a maximum output power not listed above, the recommended separation distance *d* in metres (m) can be estimated using the equation applicable to the frequency of the transmitter, where *P* is the maximum output power rating of the transmitter in watts (W) according to the transmitter manufacturer.

Note 1: At 80 MHz and 800 MHz, the separation distance for the higher frequency range applies.

Note 2: These guidelines may not apply in all situations. Electromagnetic propagation is affected by absorption and reflection from structures, objects and people.

13 WARRANTY AND SERVICE

The Portable Nebulizer includes a 3-year warranty covering the product material and manufacturing defects. The warranty does not cover:

- Damage resulting from incorrect operation and mishandling.
- Wearable parts (e.g. mesh transducer module, masks, mask connector, mouthpiece)
- Defects that the customer was already aware of at the time of purchase.
- Damage for which the customer is responsible.

The customer's statutory rights are not affected by the guarantee.

The customer must be able to show proof of purchase before any warranty claim can be entertained within the warranty period.

It is suggested to change the mesh transducer module at least once a year.



Manufactured For:
Aura Medical LLC
Brooklyn, NY 11205

For support please contact us at:
Phone: 516-253-1063
Email: support@aura-medical.com
Web: www.aura-medical.com